

LOC	DIST	REVISIONS			
P	LTR	DESCRIPTION	DATE	DWN	APVD
AF	50				
	N2	REVISED PER ECO-12-009221	15MAY12	JR	PD
	N3	REVISED PER ECO-13-000154	09JAN13	B.P	YH.M

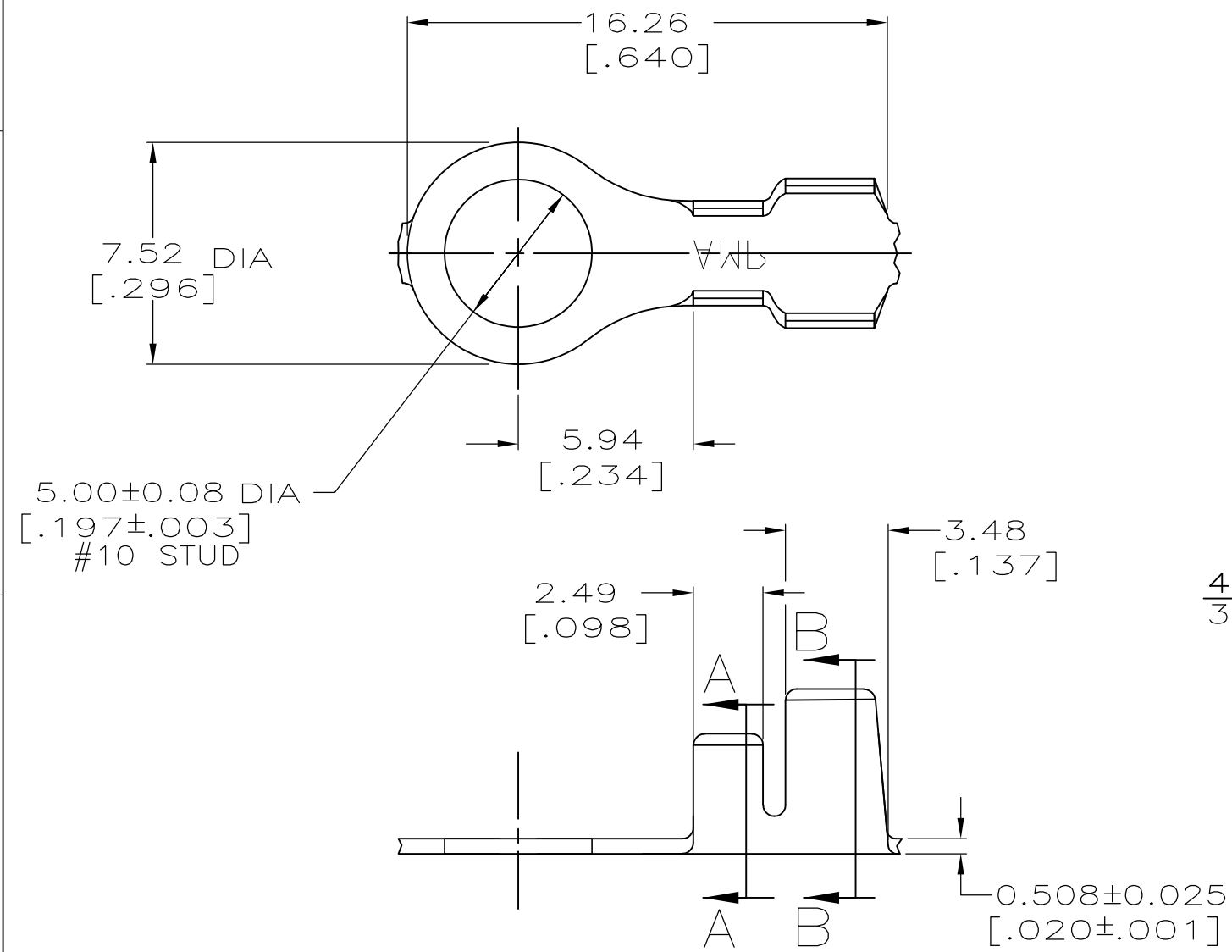

- 1 CONTINUOUS STRIP ON REEL.
- △ 2 P/N 41333-2 IS SAME AS P/N 41333 EXCEPT IS REVERSE REELED.
- 3 P/N 41333-4 IS NICKEL PLATED STEEL.

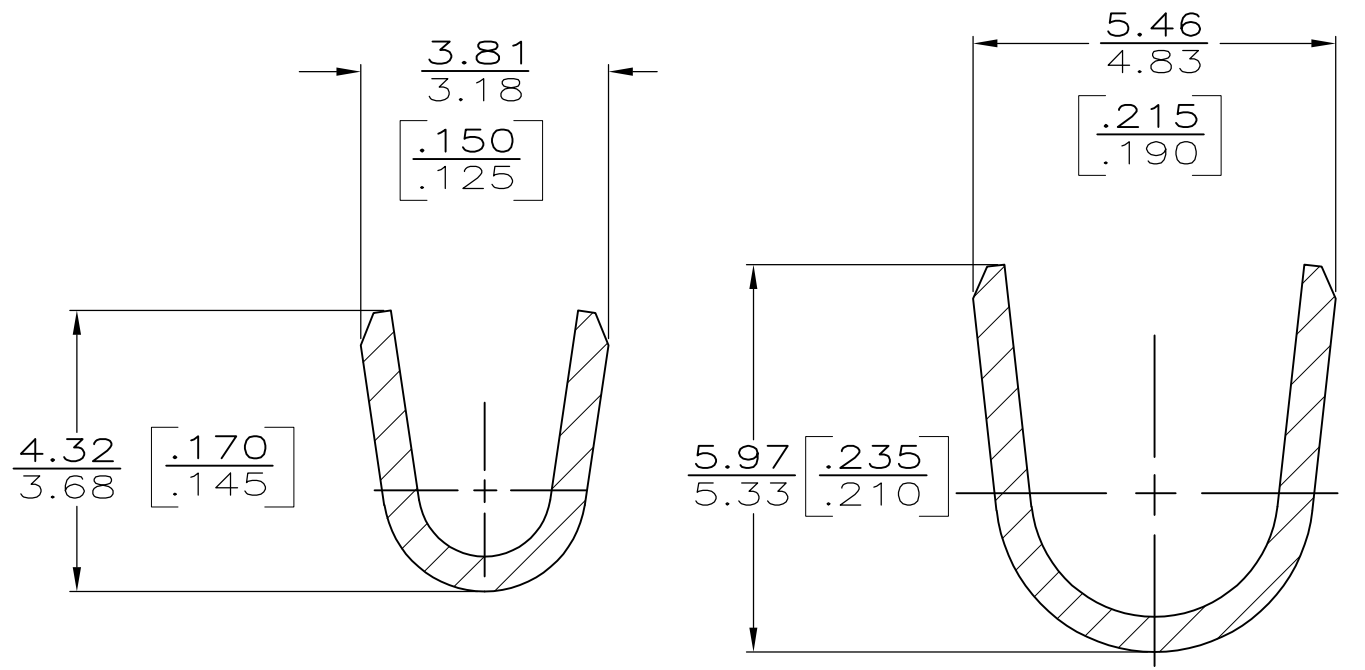

SECTION A-A
SCALE 10:1

SECTION B-B
SCALE 10:1

METRIC

TYPE	WIDTH	STRIP LENGTH	TYPE	WIDTH	HEIGHT	WIRE
F OR O	4.57 [0.180]	4.06 [0.160]	F	3.05 [0.120]	2.03 [080]	2.0MM [14]
					1.83 [072]	1.3MM [16]
					1.70 [067]	0.8MM [18]
INSUL BARREL CRIMP		±0.38 [±0.015]	WIRE BARREL CRIMP		±0.051 [±0.002]	

THIS DRAWING IS A CONTROLLED DOCUMENT.		DWN B.P 1/09/13	STE TE Connectivity	
DIMENSIONS: mm[INCHES]		CHK F.M 1/11/13		
TOLERANCES UNLESS OTHERWISE SPECIFIED:		APVD YH.M 1/15/13	NAME RING	
0 PLC ± -		PRODUCT SPEC -	-	
1 PLC ± -		APPLICATION SPEC -	-	
2 PLC ± 0.25 [0.010]		WEIGHT -	SIZE A3	CAGE CODE 00779
3 PLC ± -		CUSTOMER DRAWING	DRAWING NO C-41333	RESTRICTED TO -
4 PLC ANGLES ± -		SCALE 5:1	SHEET 1 OF 1	REV N3
MATERIAL 082 BRASS	FINISH TIN			