



EMC Components / ESD Components CONTENTS

Classification	Product Item	Part No.	Page	
Safety Precautions (Common precautions for EMC Components and ESD Suppressor)			2	
EMC Components	Common mode Noise Filters	EXC X4CZ	3	
		EXC X4CH	5	
		EXC X4CE	7	
		EXC X4CT	9	
		EXC 14CH	11	
		EXC 14CG, 14CE	13	
		EXC 14CT	16	
		EXC 14CX	18	
		EXC 16CT	20	
		EXC 24CH	22	
		EXC 24CG	24	
		EXC 24CE, 24CF	26	
		EXC 34CG, 34CE	28	
		Common mode Noise Filter Array	EXC 18CG, 18CE	30
	EXC 28CH		32	
	EXC 28CG		34	
	EXC 28CE		36	
	Packaging methods, Land pattern and Soldering conditions for Common mode Noise Filters / Array			38
	Common mode Noise Filters with ESD Suppressor	EXC 14CS	40	
		EXC 24CS	42	
Common mode Noise Filter Array with ESD Suppressor	EXC 18CS	44		
Packaging methods and Soldering conditions for Common mode Noise Filters with ESD Suppressor			46	
2 mode Noise Filters	EXC 14CP	48		
	EXC 24CB, 24CP, 24CN	50		
Packaging methods, Land pattern and Soldering conditions for 2 mode Noise Filters			53	
Performance for Common mode Noise Filters/Common mode Noise Filters with ESD Suppressor/ 2 mode Noise Filters			55	
Safety precautions for Common mode Noise Filters/Common mode Noise Filters with ESD Suppressor/ 2 mode Noise Filters			56	
ESD Components	ESD Suppressor	EZA EG2A, EG3A	57	
		EZA EG1N, EG2N	59	
	ESD Suppressor Array	EZA EGCA	61	
	ESD Suppressor High Withstanding Type	EZA EG3W	63	
	Packaging methods, Soldering conditions and Safety precautions for ESD Suppressor / Array			65
	Multilayer Varistor (Automotive Grade)	EZJ Z-M / EZJ P-M	66	
	Multilayer Varistor (DC voltage lines / High speed signal lines)	EZJ Z / EZJ P	77	
	Multilayer Varistor (DC voltage lines)	EZJ S	82	
	Common specifications Packaging methods and Safety precautions for Multilayer Varistor			84

All products in this catalog comply with the RoHS Directive.

The RoHS Directive is “the Directive (2011/65/EU) on the Restriction of the Use of Certain Hazardous Substances in Electrical and Electronic Equipment “ and its revisions.

⚠ Safety Precautions (Common precautions for EMC Components and ESD Suppressor)

- When using our products, no matter what sort of equipment they might be used for, be sure to make a written agreement on the specifications with us in advance. The design and specifications in this catalog are subject to change without prior notice.
- Do not use the products beyond the specifications described in this catalog.
- This catalog explains the quality and performance of the products as individual components. Before use, check and evaluate their operations when installed in your products.
- Install the following systems for a failsafe design to ensure safety if these products are to be used in equipment where a defect in these products may cause the loss of human life or other significant damage, such as damage to vehicles (automobile, train, vessel), traffic lights, medical equipment, aerospace equipment, electric heating appliances, combustion/gas equipment, rotating equipment, and disaster/crime prevention equipment.
- * Systems equipped with a protection circuit and a protection device
- * Systems equipped with a redundant circuit or other system to prevent an unsafe status in the event of a single fault

(1) Precautions for use

- These products are designed and manufactured for general and standard use in general electronic equipment (e.g. AV equipment, home electric appliances, office equipment, information and communication equipment)
- These products are not intended for use in the following special conditions. Before using the products, carefully check the effects on their quality and performance, and determine whether or not they can be used.
 1. In liquid, such as water, oil, chemicals, or organic solvent
 2. In direct sunlight, outdoors, or in dust
 3. In salty air or air with a high concentration of corrosive gas, such as Cl₂, H₂S, NH₃, SO₂, or NO₂
 4. Electric Static Discharge (ESD) Environment (except ESD Suppressors)
These components are sensitive to static electricity and can be damaged under static shock (ESD). Please take measures to avoid any of these environments.
Smaller components are more sensitive to ESD environment.
 5. Electromagnetic Environment
Avoid any environment where strong electromagnetic waves exist.
 6. In an environment where these products cause dew condensation
 7. Sealing or coating of these products or a printed circuit board on which these products are mounted, with resin or other materials
- These products generate Joule heat when energized. Carefully position these products so that their heat will not affect the other components.
- Carefully position these products so that their temperatures will not exceed the category temperature range due to the effects of neighboring heat-generating components. Do not mount or place heat-generating components or inflammables, such as vinyl-coated wires, near these products.
- Note that non-cleaning solder, halogen-based highly active flux, or water-soluble flux may deteriorate the performance or reliability of the products.
- Carefully select a flux cleaning agent for use after soldering. An unsuitable agent may deteriorate the performance or reliability. In particular, when using water or a water-soluble cleaning agent, be careful not to leave water residues. Otherwise, the insulation performance may be deteriorated.

(2) Precautions for storage

- Do not store these products in the following conditions. Otherwise, their electrical performance and/or solderability may be deteriorated, and the packaging materials (e.g. taping materials) may be deformed or deteriorated, resulting in mounting failures.
 1. In salty air or in air with a high concentration of corrosive gas, such as Cl₂, H₂S, NH₃, SO₂, or NO₂
 2. In direct sunlight

<Package markings>

Package markings include the product number, quantity, and country of origin. In principle, the country of origin should be indicated in English.

Common mode Noise Filters

Type: **EXCX4CZ**



Features

- Small and thin (L 0.65 mm×W 0.50 mm×H 0.30 mm)
- High-common mode attenuation at 2.4GHz, Suitable for noise suppression at Wi-Fi band
- Strong multilayer/sintered structure, excellent reflow resistance and high mounting reliability
- Lead, halogen and antimony-free
- RoHS compliant

Recommended Applications

- Smartphones, Tablet PCs and DSC
- Suppresses noise radiation to Wi-Fi Equipment

Explanation of Part Numbers

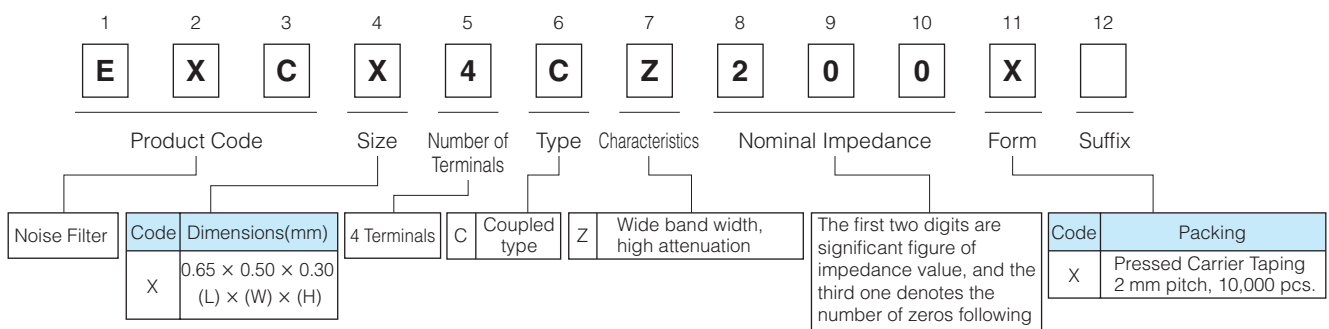

Construction

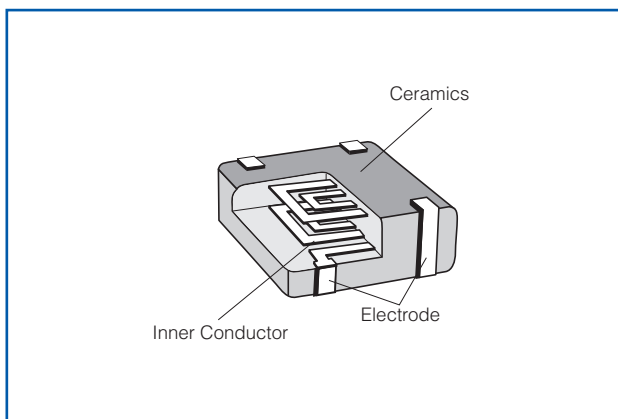

Dimensions in mm (not to scale)

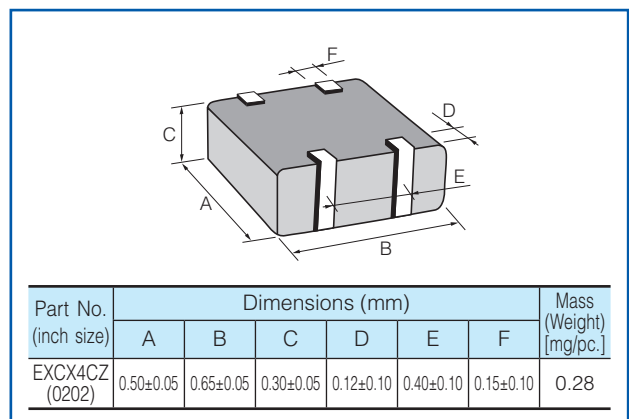

Circuit Configuration (No Polarity)

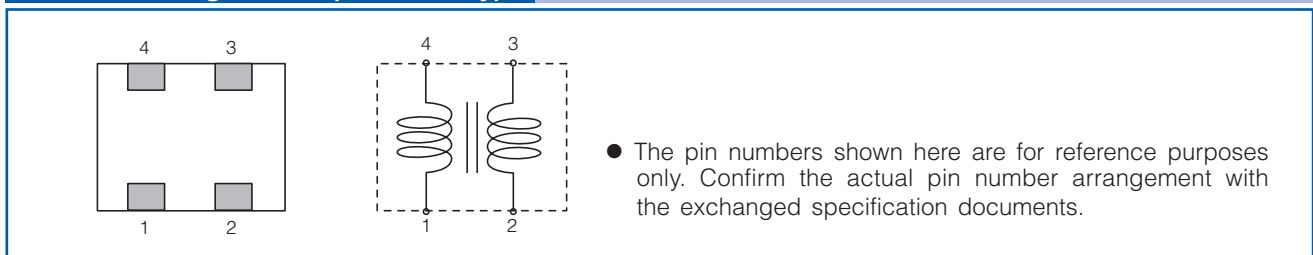

Ratings

Part Number	Impedance (Ω) at 100 MHz	Rated Voltage (V DC)	Rated Current (mA DC)	DC Resistance (Ω)max.
	Common Mode			
EXCX4CZ200X	20 Ω ±30 %	10	100	3.0±30 %

- Category Temperature Range -40 °C to +85 °C

Impedance Characteristics (Typical)

- EXCX4CZ200X

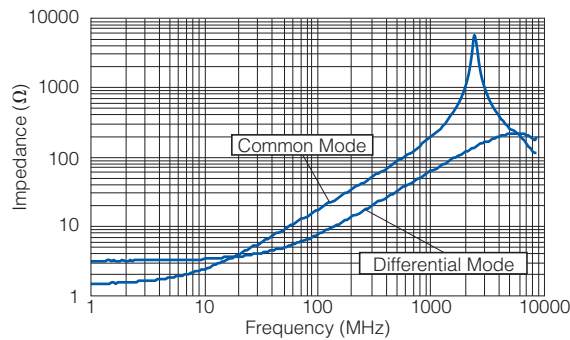

- Measurement Circuit

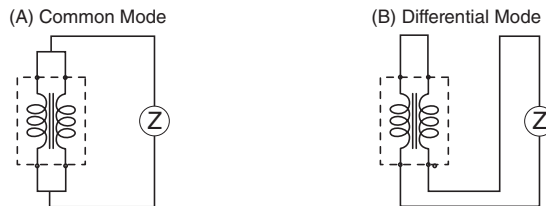

Attenuation Characteristics (Typical)

- EXCX4CZ200X

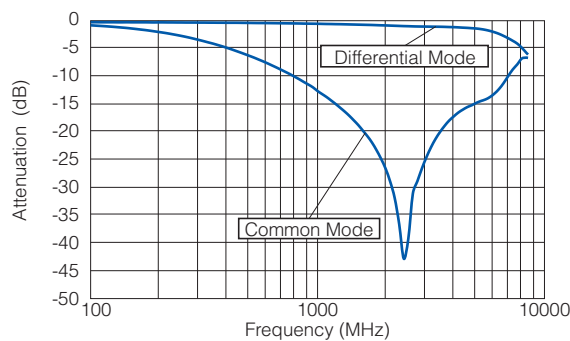

- As for Packaging Methods, Land Pattern, Soldering Conditions and Safety Precautions, Please see Data Files

Common mode Noise Filters

Type: **EXCX4CH**

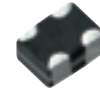

Features

- Small and thin (L 0.65 mm×W 0.50 mm×H 0.30 mm)
- High common mode attenuation in high-speed differential transmission lines, Cut-off frequency is more than 8.5 GHz, and an influence to differential transmission signal quality is little
- Strong multilayer/sintered structure, excellent reflow resistance and high mounting reliability
- Lead, halogen and antimony-free
- RoHS compliant

Recommended Applications

- Smartphones, Tablet PCs and DSC
- Noise suppression of high-speed differential data lines such as USB, LVDS and HDMI

Explanation of Part Numbers

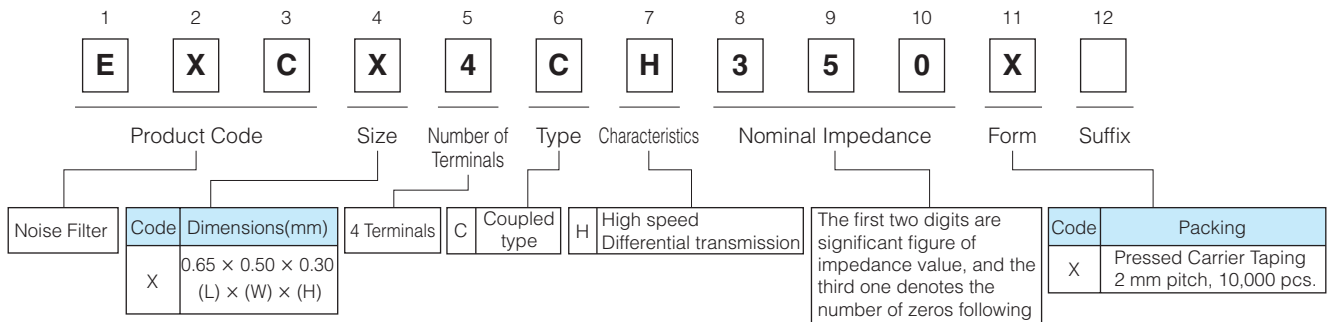

Construction

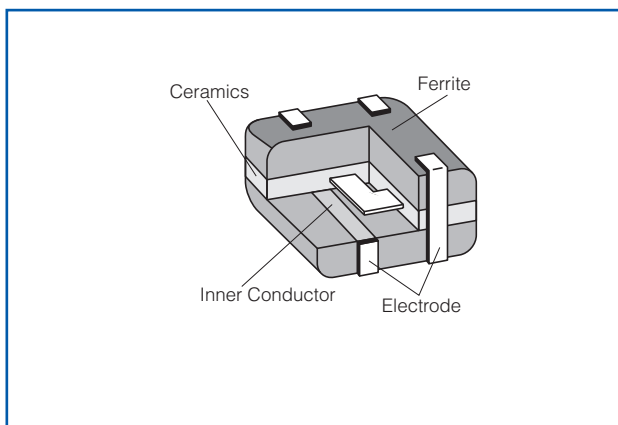

Dimensions in mm (not to scale)

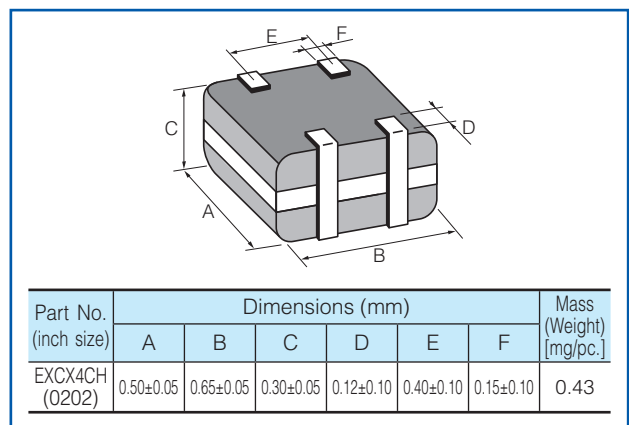

Circuit Configuration (No Polarity)

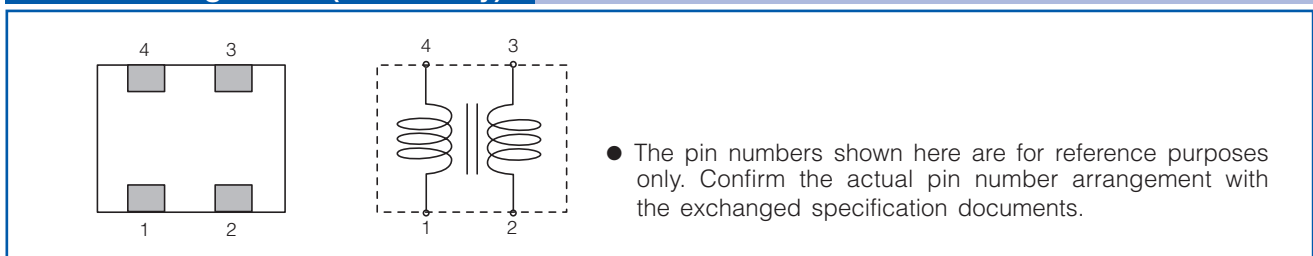

Ratings

Part Number	Impedance (Ω) at 100 MHz	Rated Voltage (V DC)	Rated Current (mA DC)	DC Resistance (Ω)max.
	Common Mode			
EXCX4CH120X	12 $\Omega \pm 5 \Omega$	5	100	2.0
EXCX4CH350X	35 $\Omega \pm 30 \%$	5	100	2.7

- Category Temperature Range $-40 \text{ }^\circ\text{C}$ to $+85 \text{ }^\circ\text{C}$

Impedance Characteristics (Typical)

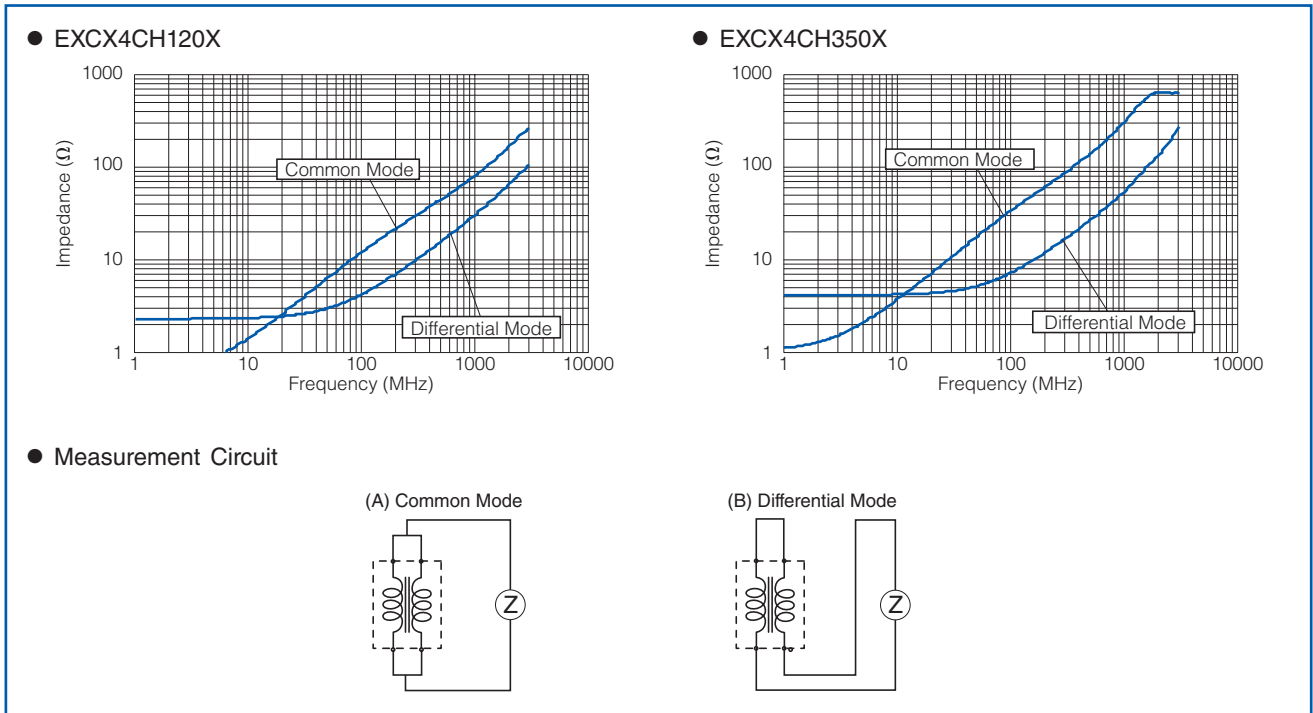

Insertion Loss (Typical)

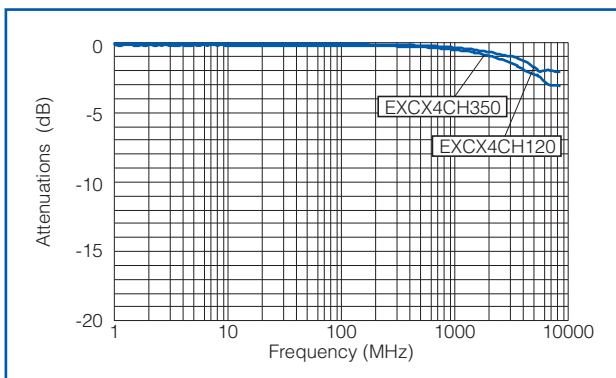

Common mode Attenuation Characteristics (Typical)

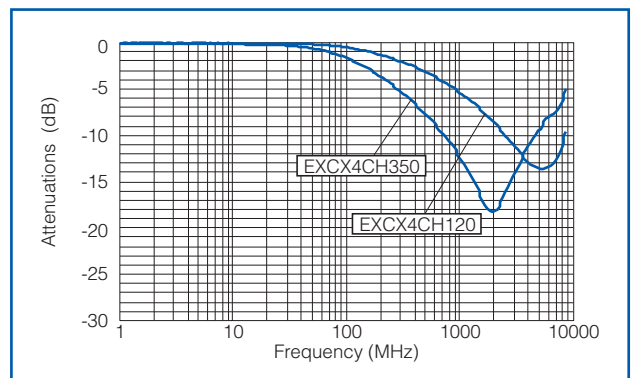

- As for Packaging Methods, Land Pattern, Soldering Conditions and Safety Precautions, Please see Data Files

Common mode Noise Filters

Type: **EXCX4CE**



Features

- Small and thin (L 0.65 mm×W 0.50 mm×H 0.30 mm)
- Noise suppression of high-speed differential transmission lines with little influence of waveform rounding on signal transmission
- Strong multilayer/sintered structure, excellent reflow resistance and high mounting reliability
- Lead, halogen and antimony-free
- RoHS compliant

Recommended Applications

- Smartphones, Tablet PCs and DSC
- Noise suppression of high-speed differential data lines such as MIPI, USB and LVDS

Explanation of Part Numbers

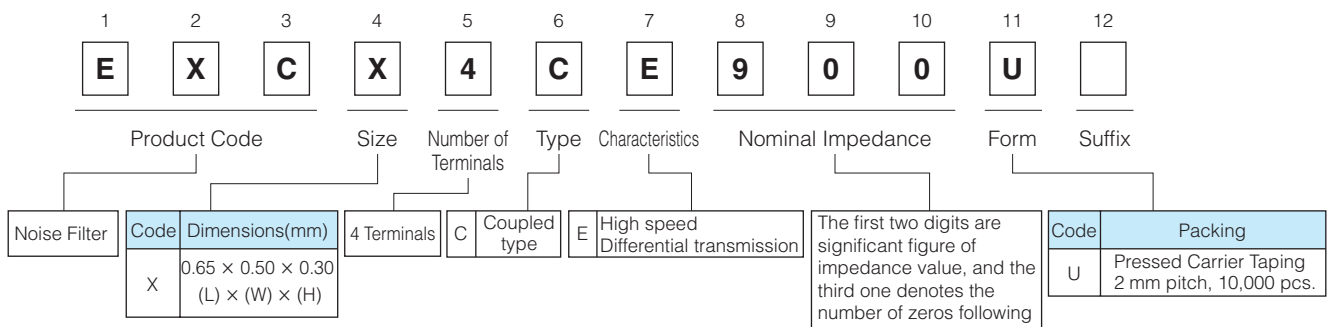

Construction

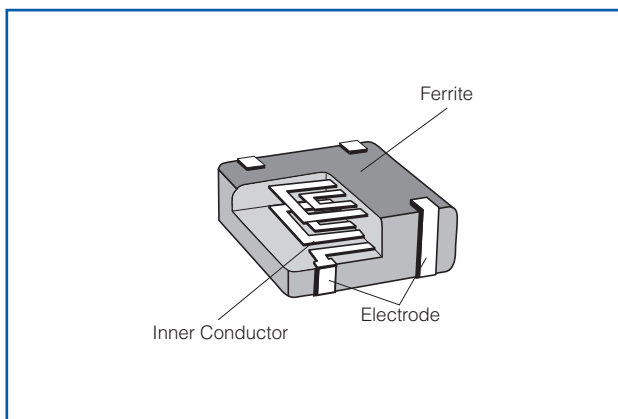

Dimensions in mm (not to scale)

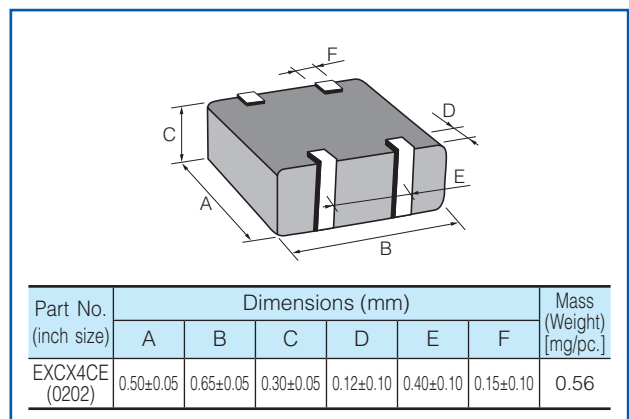

Circuit Configuration (No Polarity)

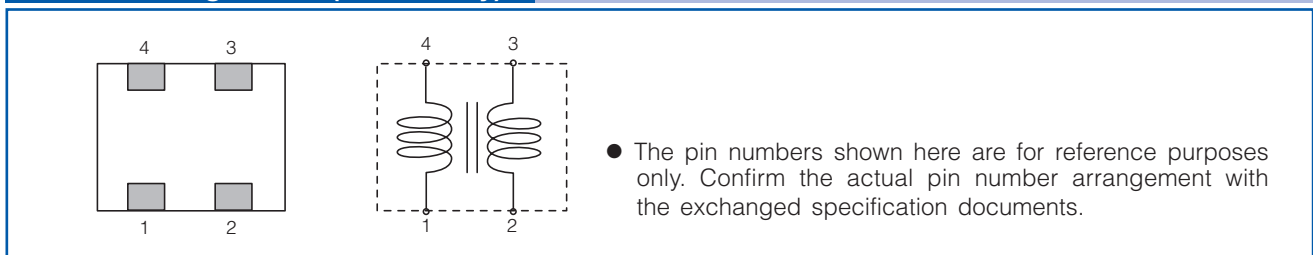

Ratings

Part Number	Impedance (Ω) at 100 MHz		Rated Voltage (V DC)	Rated Current (mA DC)	DC Resistance (Ω)max.
	Common Mode	Differential Mode			
EXCX4CE600U	60 Ω ±20 %	18 Ω max.	5	100	2.4±30 %
EXCX4CE900U	90 Ω ±20 %	20 Ω max.	5	100	3.0±30 %

- Category Temperature Range $-40\text{ }^{\circ}\text{C}$ to $+85\text{ }^{\circ}\text{C}$

Impedance Characteristics (Typical)

● EXCX4CE600U

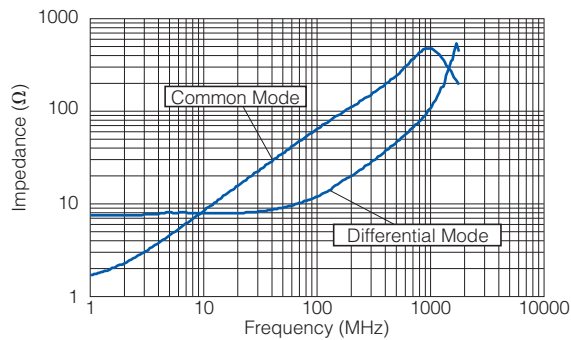

● EXCX4CE900U

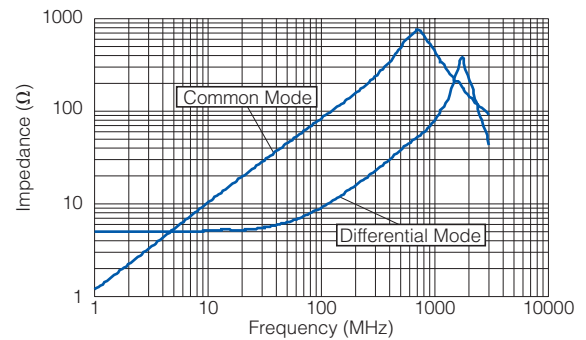

● Measurement Circuit

(A) Common Mode

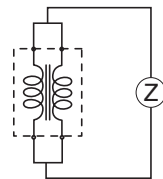

(B) Differential Mode

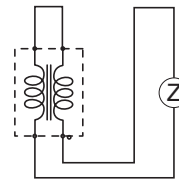

- As for Packaging Methods, Land Pattern, Soldering Conditions and Safety Precautions, Please see Data Files

Common mode Noise Filters

Type: **EXCX4CT**

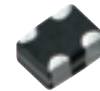

Features

- Small and thin (L 0.65 mm×W 0.50 mm×H 0.30 mm)
- High attenuation at common-mode for noise suppression of harmonic signal components and cellular frequency
- Cut-off frequency is more than 3 GHz, the insertion loss is low in differential transmission line
- Strong multilayer/sintered structure, excellent reflow resistance and high mounting reliability
- Lead, halogen and antimony-free
- RoHS compliant

Recommended Applications

- Smartphones, Tablet PCs and DSC
- Noise suppression of high-speed differential data lines such as MIPI, USB and LVDS

Explanation of Part Numbers

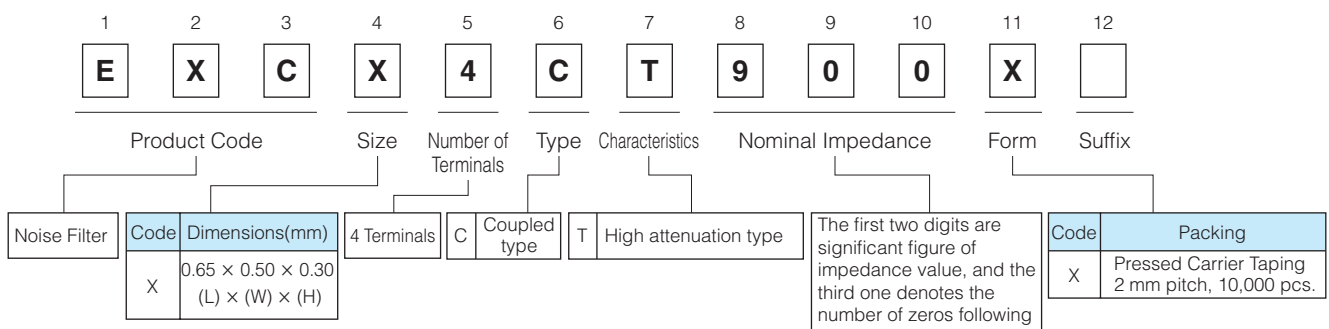

Construction

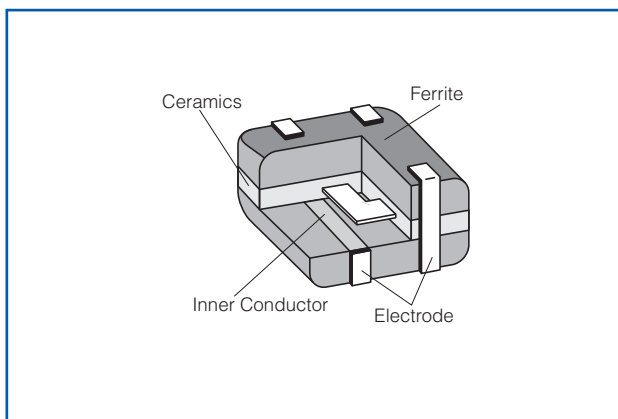

Dimensions in mm (not to scale)

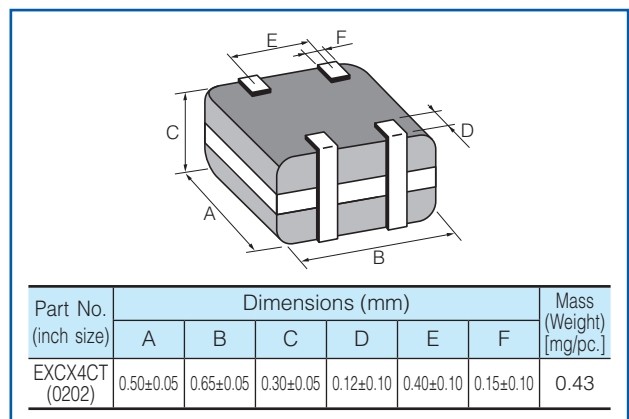

Circuit Configuration (No Polarity)

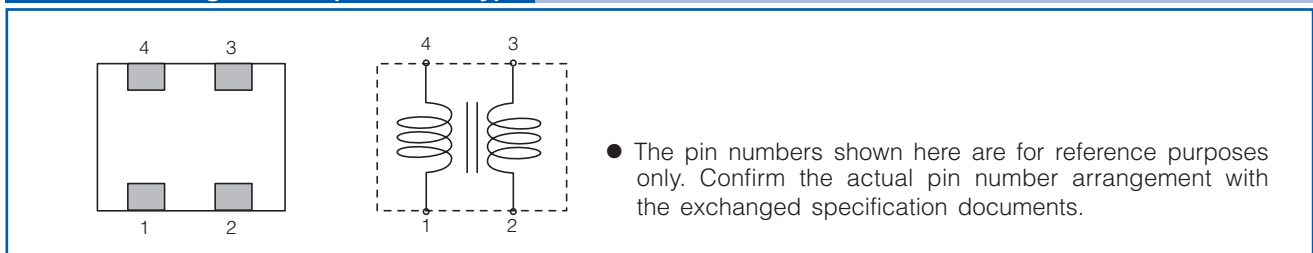

Ratings

Part Number	Impedance (Ω) at 100 MHz	Rated Voltage (V DC)	Rated Current (mA DC)	DC Resistance (Ω)
	Common Mode			
EXCX4CT650X	65 $\Omega \pm 20\%$	10	100	2.7 $\Omega \pm 30\%$
EXCX4CT900X	90 $\Omega \pm 20\%$	10	100	3.0 $\Omega \pm 30\%$

- Category Temperature Range $-40\text{ }^{\circ}\text{C}$ to $+85\text{ }^{\circ}\text{C}$

Impedance Characteristics (Typical)

● EXCX4CT650X

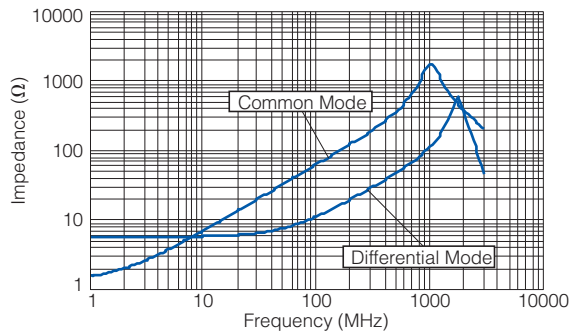

● EXCX4CT900X

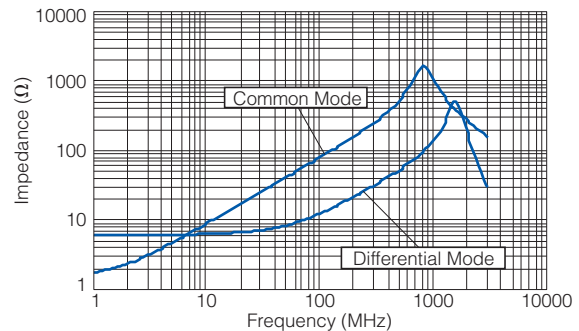

● Measurement Circuit

(A) Common Mode

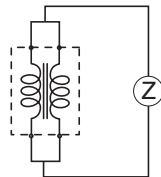

(B) Differential Mode

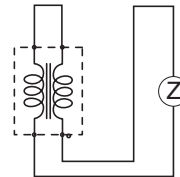

Insertion Loss (Typical)

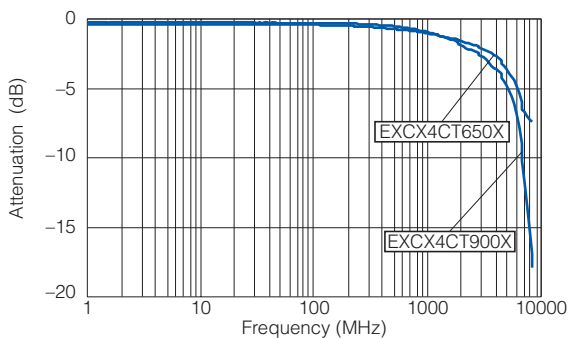

Common mode Attenuation Characteristics (Typical)

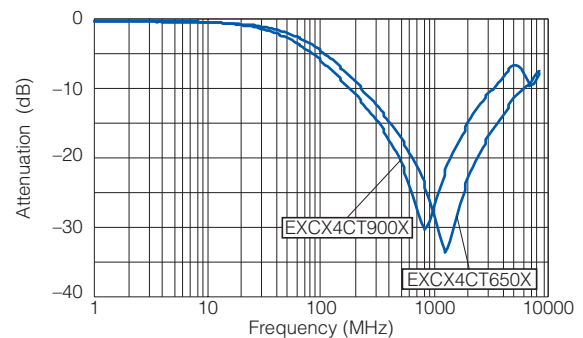

- As for Packaging Methods, Land Pattern, Soldering Conditions and Safety Precautions, Please see Data Files

Common mode Noise Filters

Type: **EXC14CH**

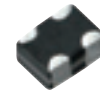

Features

- Small and thin (L 0.85 mm×W 0.65 mm×H 0.45 mm)
- High common mode attenuation in high-speed differential transmission lines, Cut-off frequency is more than 8.5 GHz, and an influence to differential transmission signal quality is little
- Strong multilayer/sintered structure, excellent reflow resistance and high mounting reliability
- Lead, halogen and antimony-free
- RoHS compliant

Recommended Applications

- Smartphones, Tablet PCs and DSC
- Noise suppression of high-speed differential data lines such as USB, LVDS and HDMI

Explanation of Part Numbers

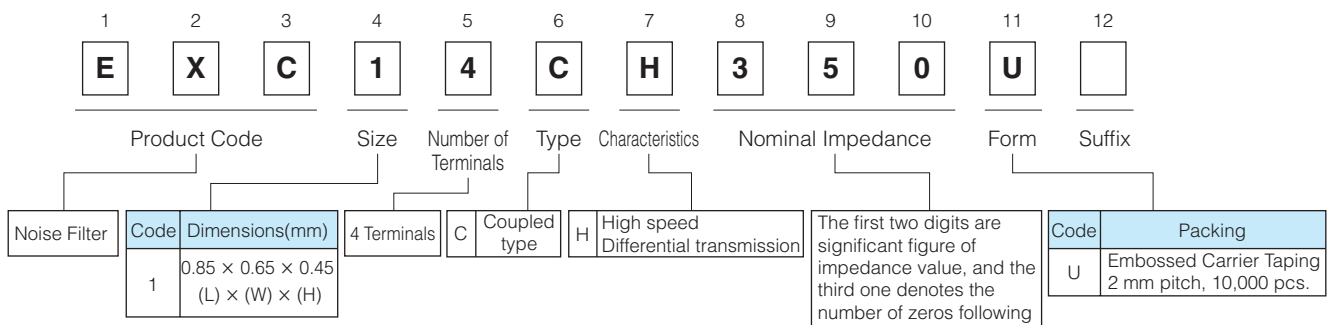

Construction

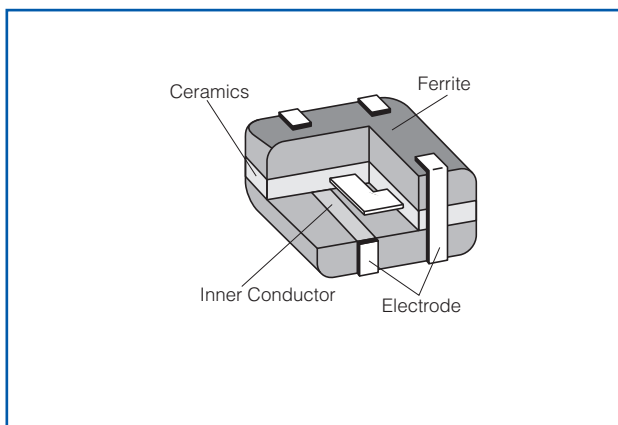

Dimensions in mm (not to scale)

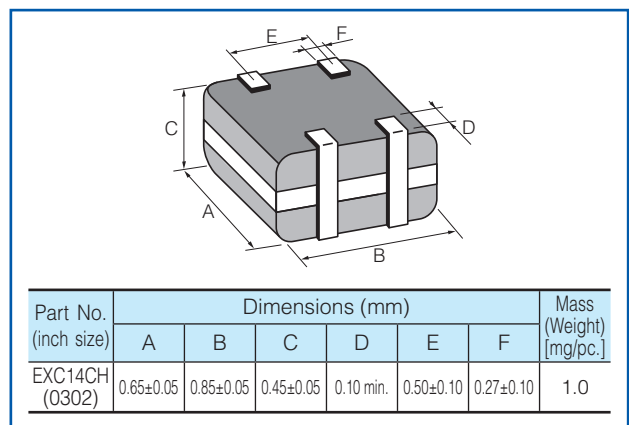

Circuit Configuration (No Polarity)

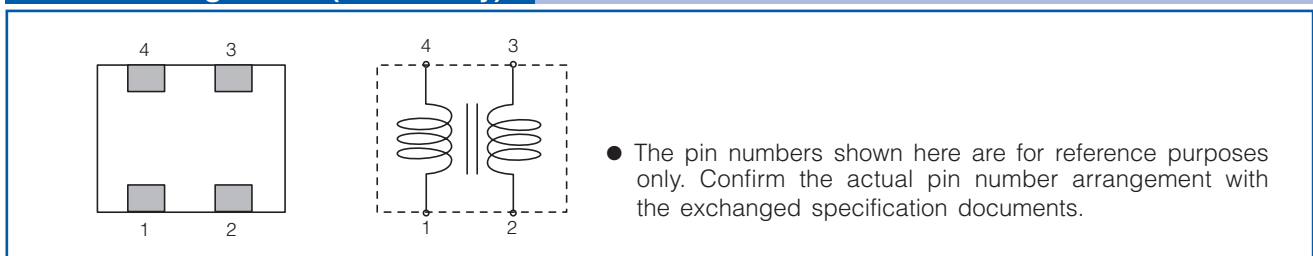

Ratings

Part Number	Impedance (Ω) at 100 MHz		Rated Voltage (V DC)	Rated Current (mA DC)	DC Resistance (Ω)max.
	Common Mode	Differential Mode			
EXC14CH120U	12 Ω \pm 25 %	10 Ω max.	5	100	1.0
EXC14CH350U	35 Ω \pm 30 %	15 Ω max.	5	100	1.5

- Category Temperature Range -40 °C to $+85$ °C

Impedance Characteristics (Typical)

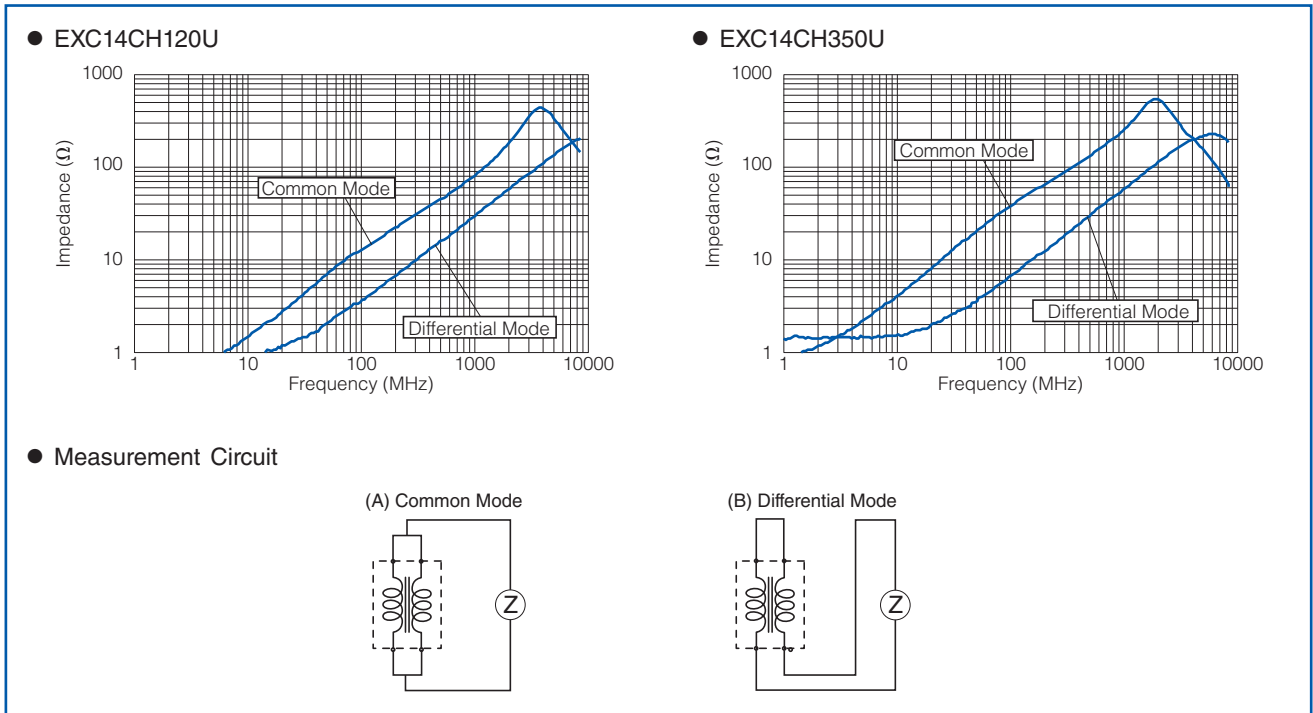

Insertion Loss (Typical)

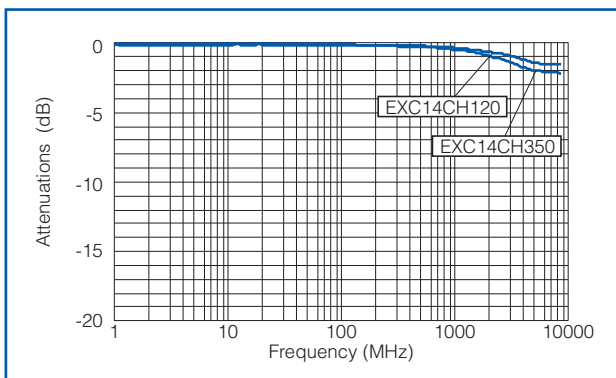

Common mode Attenuation Characteristics (Typical)

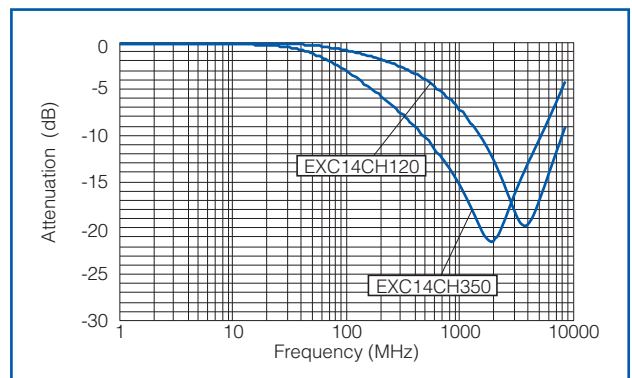

- As for Packaging Methods, Land Pattern, Soldering Conditions and Safety Precautions, Please see Data Files

Common mode Noise Filters

Type: **EXC14CG**
EXC14CE



Features

- Small and thin (L 0.85 mm×W 0.65 mm×H 0.45 mm)
- Noise suppression of high-speed differential transmission lines with little influence of waveform rounding on signal transmission
- Low DC resistance and low insertion loss
- High-Q value and high impedance of GHz zone : EXC14CG type
- Strong multilayer/sintered structure, excellent reflow resistance and high mounting reliability
- Lead, halogen and antimony-free
- RoHS compliant

Recommended Applications

- Smartphones, Tablet PCs and DSC
- Noise suppression of high-speed differential data lines such as USB, LVDS and MHL

Explanation of Part Numbers

1	2	3	4	5	6	7	8	9	10	11	12
E	X	C	1	4	C	E	9	0	0	U	
Product Code			Size	Number of Terminals	Type	Characteristics	Nominal Impedance			Form	Suffix
Noise Filter	Code	Dimensions(mm)	4 Terminals	C	Coupled type	E High speed Differential transmission G High-Q type	The first two digits are significant figure of impedance value, and the third one denotes the number of zeros following			Code	Packing
	1	0.85 × 0.65 × 0.45 (L) × (W) × (H)								U	Embossed Carrier Taping 2 mm pitch, 10,000 pcs.

Construction

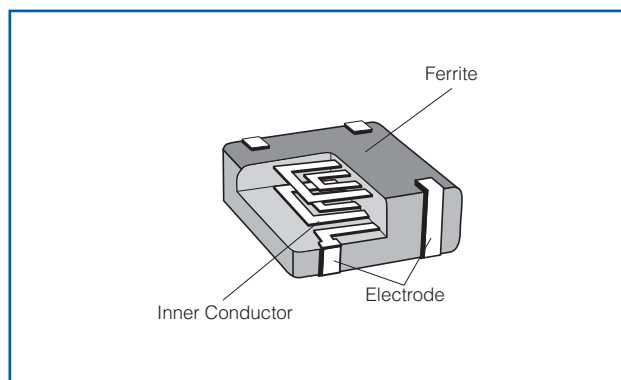

Dimensions in mm (not to scale)

Part No. (inch size)	Dimensions (mm)						Mass (Weight) [mg/pc.]
	A	B	C	D	E	F	
EXC14CG/CE (0302)	0.65±0.05	0.85±0.05	0.45±0.05	0.10 min.	0.50±0.10	0.27±0.10	1.4

Circuit Configuration(No Polarity)

● The pin numbers shown here are for reference purposes only. Confirm the actual pin number arrangement with the exchanged specification documents.

Ratings

Part Number	Impedance (Ω) at 100 MHz		Rated Voltage (V DC)	Rated Current (mA DC)	DC Resistance (Ω)max.
	Common Mode	Differential Mode			
EXC14CG120U	12 $\Omega \pm 30\%$	10 Ω max.	5	130	2.0
EXC14CG350U	35 $\Omega \pm 30\%$	15 Ω max.	5	100	2.0
EXC14CG430U	43 $\Omega \pm 25\%$	15 Ω max.	5	100	2.7
EXC14CE650U	65 $\Omega \pm 20\%$	20 Ω max.	5	130	2.5
EXC14CE900U	90 $\Omega \pm 20\%$	20 Ω max.	5	130	2.5
EXC14CE121U	120 $\Omega \pm 20\%$	20 Ω max.	5	100	3.8

- Category Temperature Range $-40\text{ }^{\circ}\text{C}$ to $+85\text{ }^{\circ}\text{C}$

Impedance Characteristics (Typical)

● EXC14CG120U

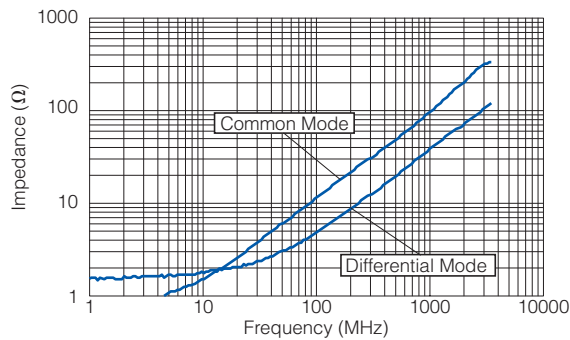

● EXC14CG350U

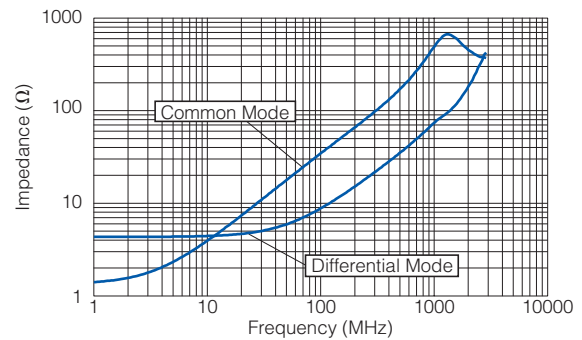

● EXC14CG430U

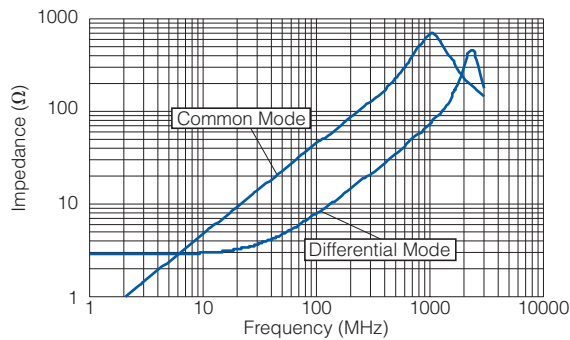

● EXC14CE650U

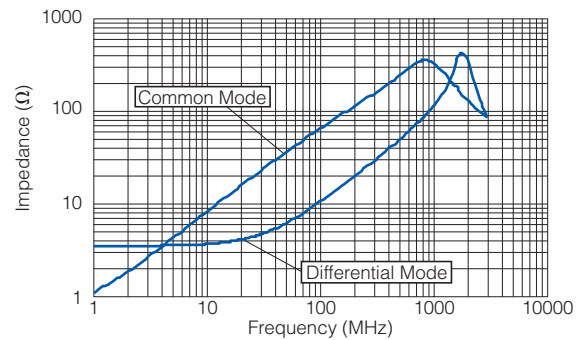

● EXC14CE900U

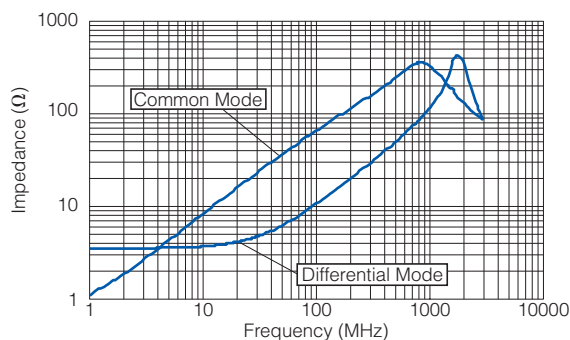

● EXC14CE121U

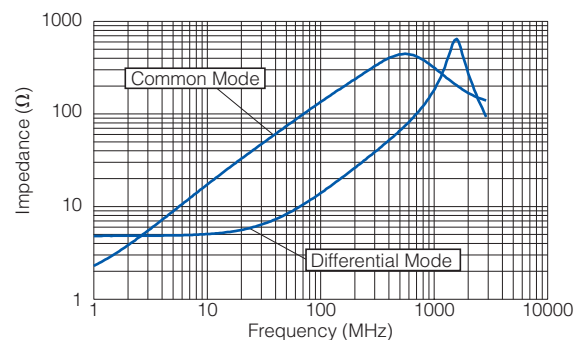

● Measurement Circuit

(A) Common Mode

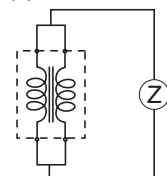

(B) Differential Mode

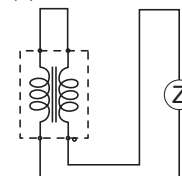

Attenuation Characteristics (Typical)

● EXC14CG120U

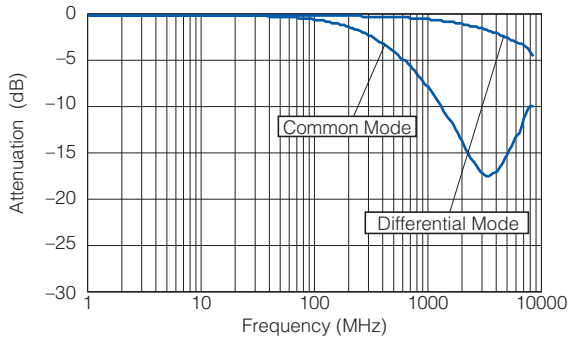

● EXC14CG350U

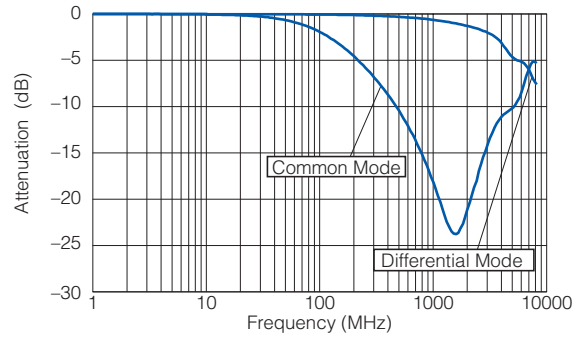

● EXC14CG430U

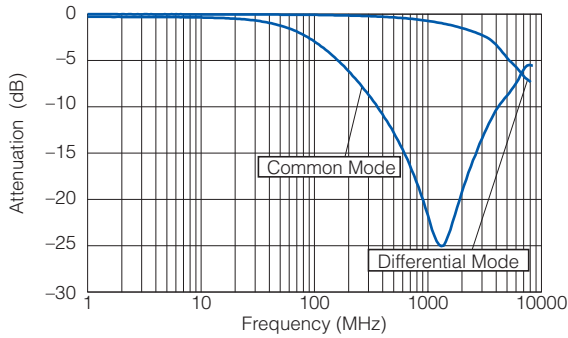

● EXC14CE650U

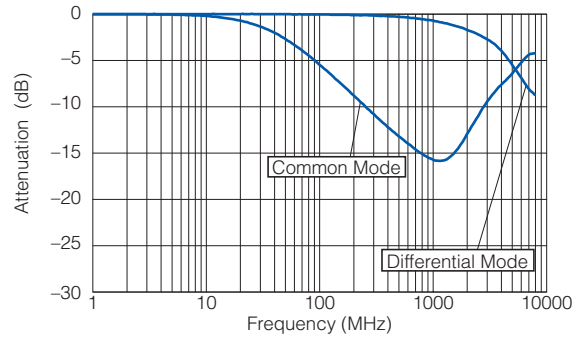

● EXC14CE900U

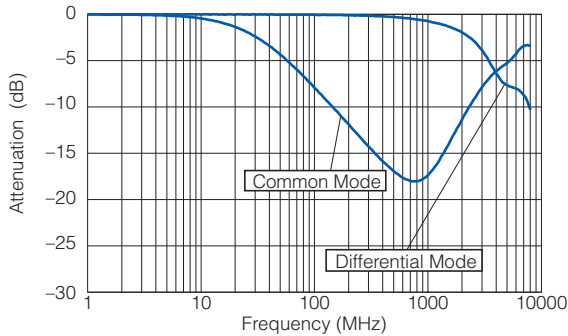

● EXC14CE121U

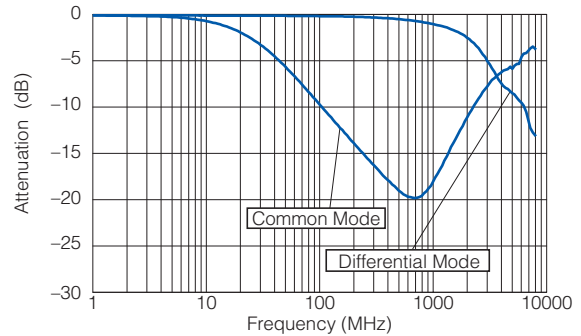

■ As for Packaging Methods, Land Pattern, Soldering Conditions and Safety Precautions, Please see Data Files

Common mode Noise Filters

Type: **EXC14CT**



Features

- Small and thin (L 0.85 mm×W 0.65 mm×H 0.45 mm)
- High attenuation at common-mode for noise suppression of harmonic signal components and cellular frequency
- High cut-off frequency and capability of coping with high-speed signals (USB and HDMI)
- Strong multilayer/sintered structure, excellent reflow resistance and high mounting reliability
- Lead, halogen and antimony-free
- RoHS compliant

Recommended Applications

- Smartphones, Tablet PCs and DSC
- Noise suppression of high-speed differential data lines such as MIPI, USB and LVDS

Explanation of Part Numbers

1	2	3	4	5	6	7	8	9	10	11	12
E	X	C	1	4	C	T	9	0	0	U	
Product Code			Size	Number of Terminals	Type	Characteristics	Nominal Impedance			Form	Suffix

Noise Filter	Code	Dimensions(mm)	4 Terminals	C	Coupled type	T	High attenuation type	The first two digits are significant figure of impedance value, and the third one denotes the number of zeros following	Code	Packing
	1	0.85 × 0.65 × 0.45 (L) × (W) × (H)							U	Embossed Carrier Taping 2 mm pitch, 10,000 pcs.

Construction

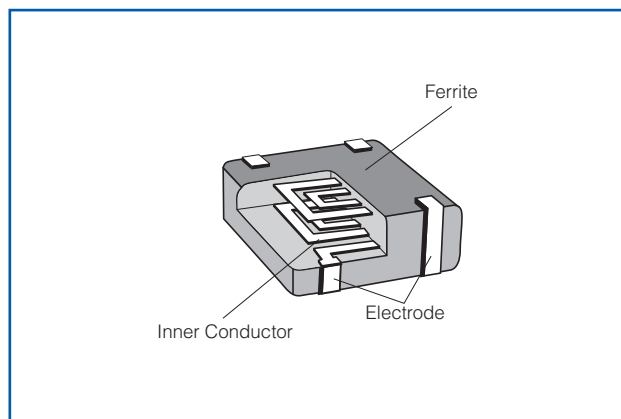

Dimensions in mm (not to scale)

Part No. (inch size)	Dimensions (mm)						Mass (Weight) [mg/pc.]
	A	B	C	D	E	F	
EXC14CT (0302)	0.65±0.05	0.85±0.05	0.45±0.05	0.10 min.	0.50±0.10	0.27±0.10	1.0

Circuit Configuration (No Polarity)

- The pin numbers shown here are for reference purposes only. Confirm the actual pin number arrangement with the exchanged specification documents.

Ratings

Part Number	Impedance (Ω) at 100 MHz		Rated Voltage (V DC)	Rated Current (mA DC)	DC Resistance (Ω)max.
	Common Mode	Differential Mode			
EXC14CT500U	50 Ω ±25 %	17 Ω max.	5	100	2.3 Ω ±30 %
EXC14CT900U	90 Ω ±20 %	20 Ω max.	5	100	3.3 Ω ±30 %

- Category Temperature Range -40 °C to +85 °C

Impedance Characteristics (Typical)

● EXC14CT500U

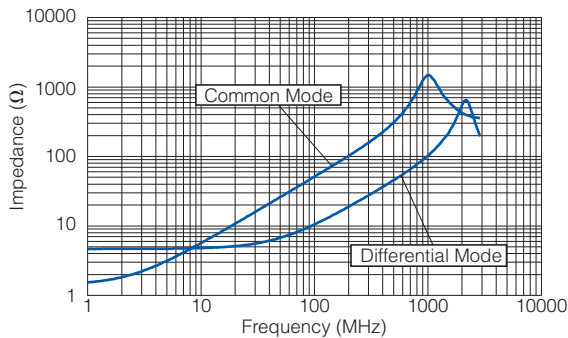

● EXC14CT900U

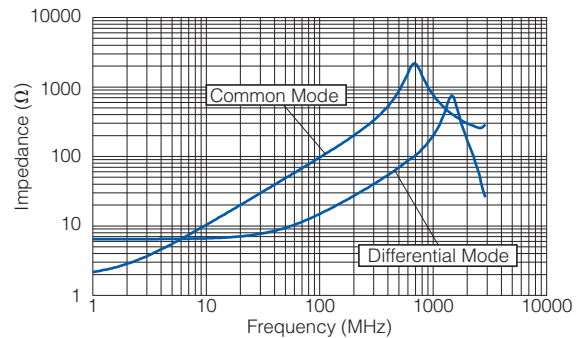

● Measurement Circuit

(A) Common Mode

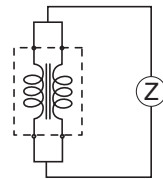

(B) Differential Mode

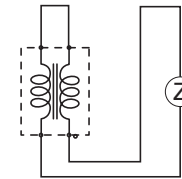

Attenuation Characteristics (Typical)

● EXC14CT500U

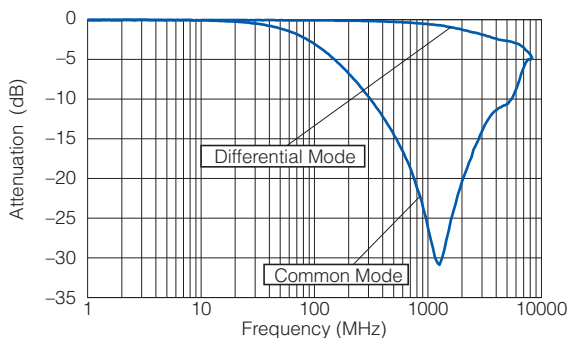

● EXC14CT900U

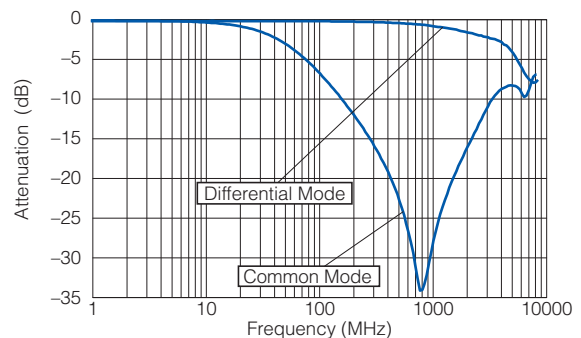

- As for Packaging Methods, Land Pattern, Soldering Conditions and Safety Precautions, Please see Data Files

Common mode Noise Filters

Type: **EXC14CX**



Features

- Small and thin (L 0.85 mm×W 0.65 mm×H 0.45 mm)
- Effective noise suppression of smartphones by eliminating common mode noises and removing differential signal components
- Strong multilayer/sintered structure, excellent reflow resistance and high mounting reliability
- Lead, halogen and antimony-free
- RoHS compliant

Recommended Applications

- Smartphones, Tablet PCs and DSC
- Noise suppression of high-speed differential data lines such as MIPI, USB and LVDS

Explanation of Part Numbers

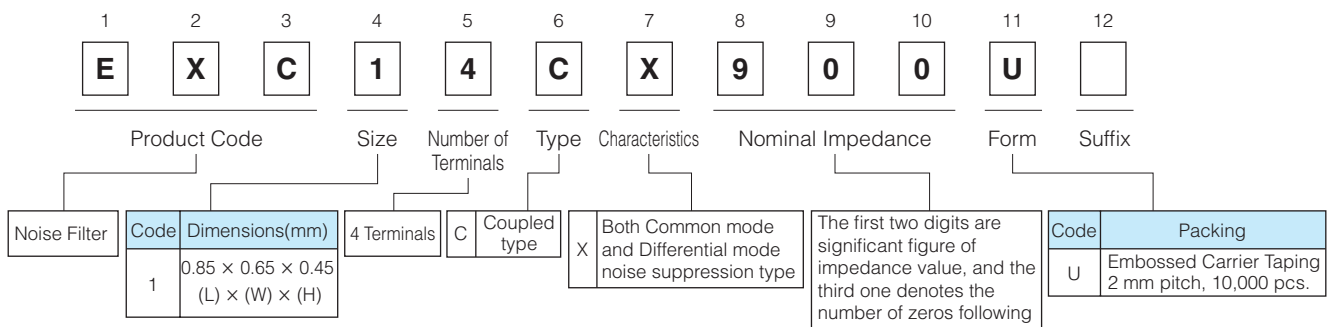

Construction

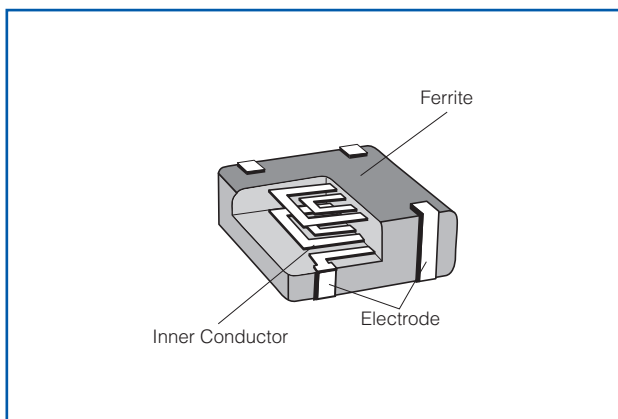

Dimensions in mm (not to scale)

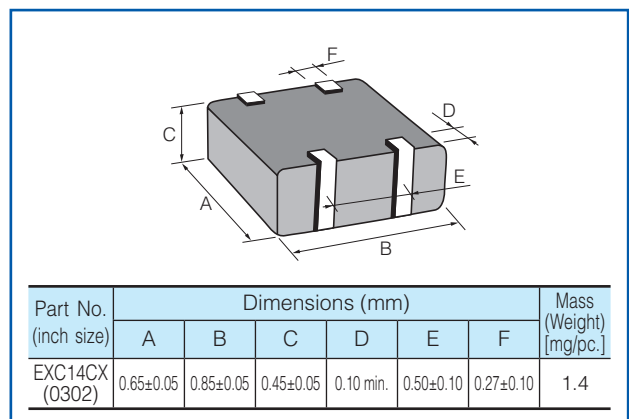

Circuit Configuration (No Polarity)

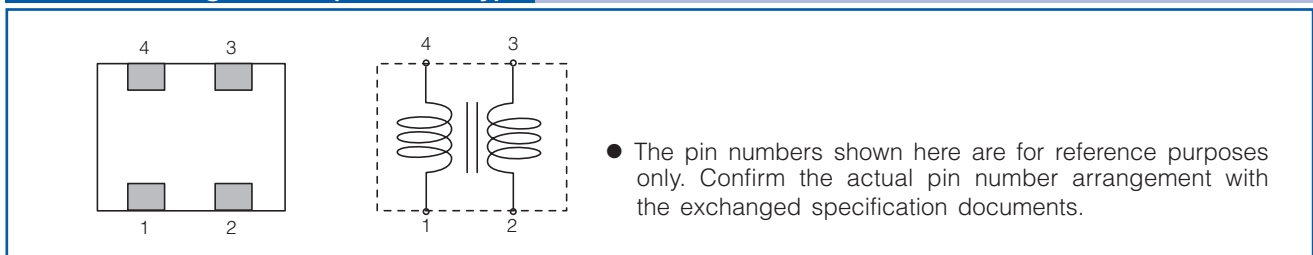

Ratings

Part Number	Impedance (Ω) at 100 MHz		Rated Voltage (V DC)	Rated Current (mA DC)	DC Resistance (Ω)max.
	Common Mode	Differential Mode			
EXC14CX280U	28 $\Omega \pm 25\%$	25 Ω max.	5	100	3.0
EXC14CX400U	40 $\Omega \pm 25\%$	30 Ω max.	5	100	4.0

- Category Temperature Range $-40\text{ }^{\circ}\text{C}$ to $+85\text{ }^{\circ}\text{C}$

Impedance Characteristics (Typical)

● EXC14CX280U

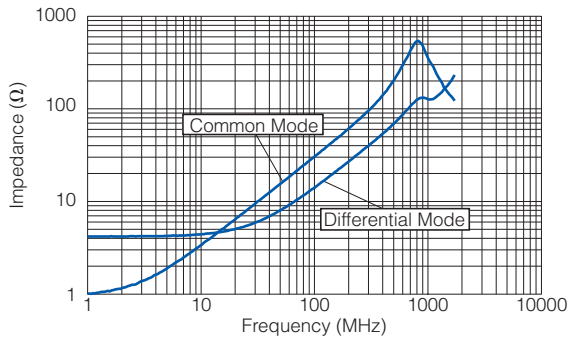

● EXC14CX400U

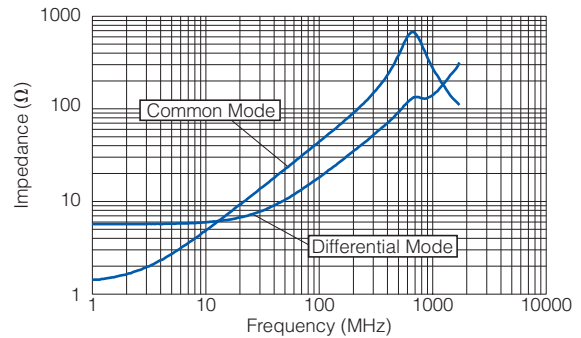

● Measurement Circuit

(A) Common Mode

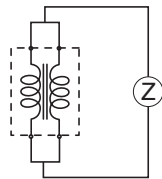

(B) Differential Mode

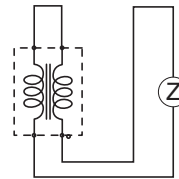

Attenuation Characteristics (Typical)

● EXC14CX280U

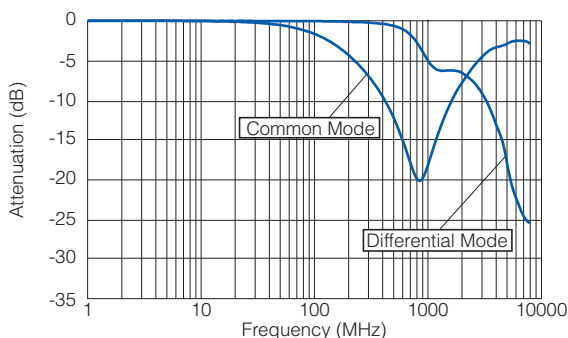

● EXC14CX400U

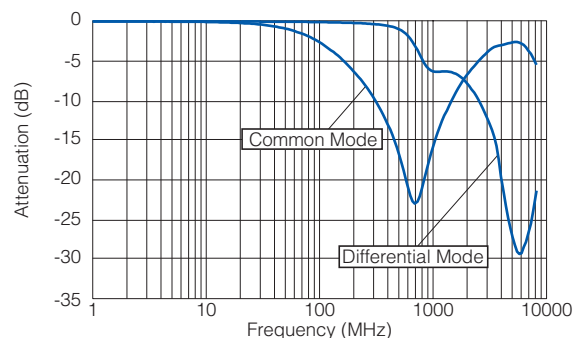

■ **As for Packaging Methods, Land Pattern, Soldering Conditions and Safety Precautions,**
Please see Data Files

Common mode Noise Filters

Type: **EXC16CT**



Features

- Corresponding to new high-speed differential interface (MIPI C-PHY)
Corresponding to 3-line transmission, transmission rate up to 2.5 Gbps
- Unique plating fine coil process and ceramic multilayer process enable compact size
(L 0.9.0 mm×W 0.68 mm×H 0.40 mm)
around 40% reduction of mounting area (comparing with MIPI D-PHY)
- Strong multilayer/sintered structure, excellent reflow resistance and high mounting reliability
- Lead, halogen and antimony-free
- RoHS compliant

Recommended Applications

- High resolution camera and display equipped mobile devices (Smartphones, Tablet PCs and wearable)
- Noise suppression of high-speed differential data lines such as MIPI C-PHY

Explanation of Part Numbers

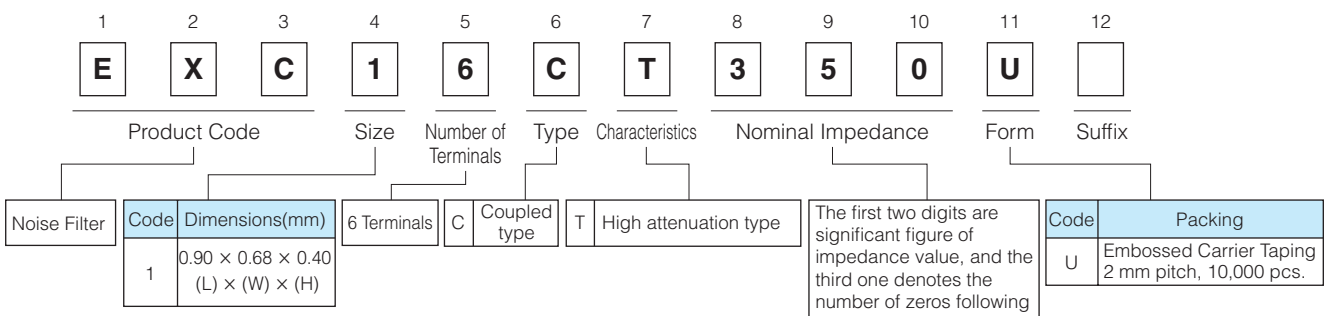

Construction

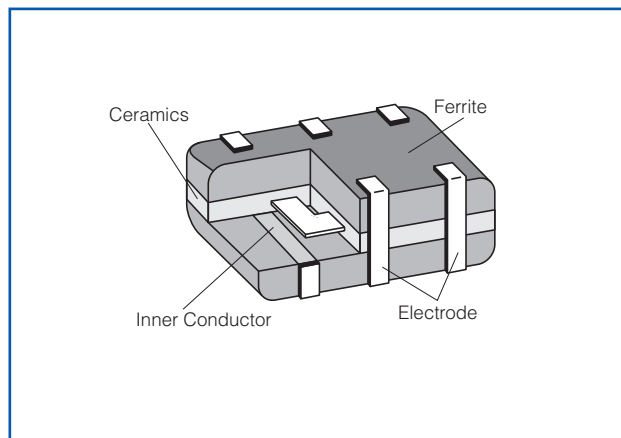

Dimensions in mm (not to scale)

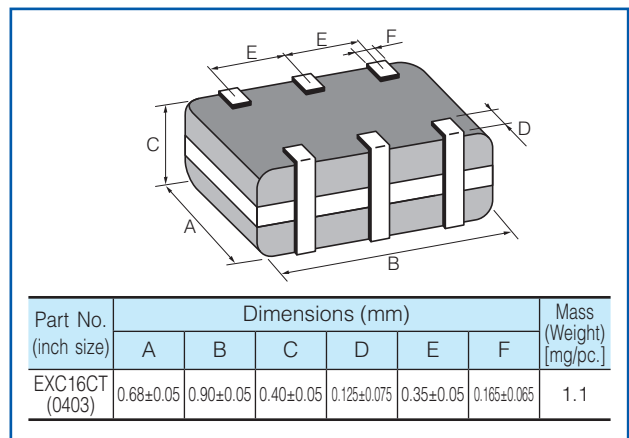

Circuit Configuration (No Polarity)

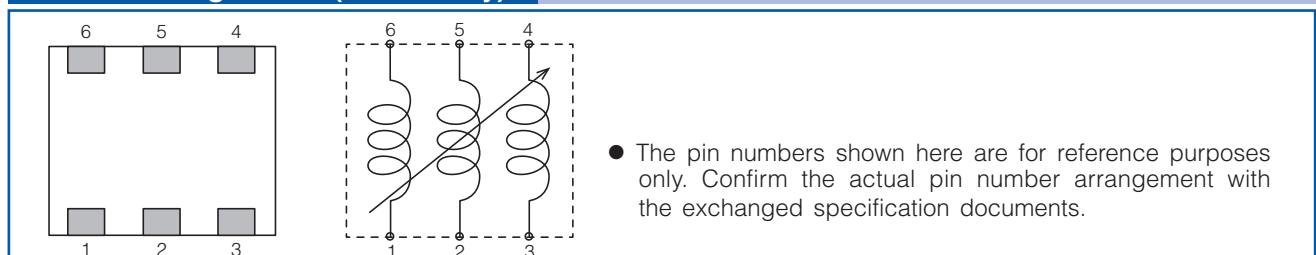

Part Number	Impedance (Ω) at 100 MHz	Rated Voltage (V DC)	Rated Current (mA DC)	DC Resistance (Ω) max.
	Common Mode			
EXC16CT250U	25 $\Omega \pm 25\%$	5	100	3.0
EXC16CT350U	35 $\Omega \pm 25\%$	5	100	4.0

● Category Temperature Range $-40\text{ }^{\circ}\text{C}$ to $+85\text{ }^{\circ}\text{C}$

Common mode Impedance Characteristics (Typical)

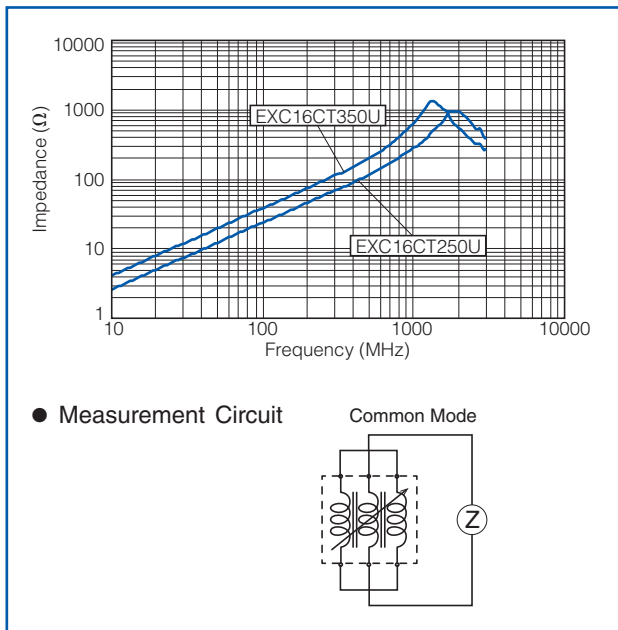

Common mode Attenuation Characteristics (Typical)

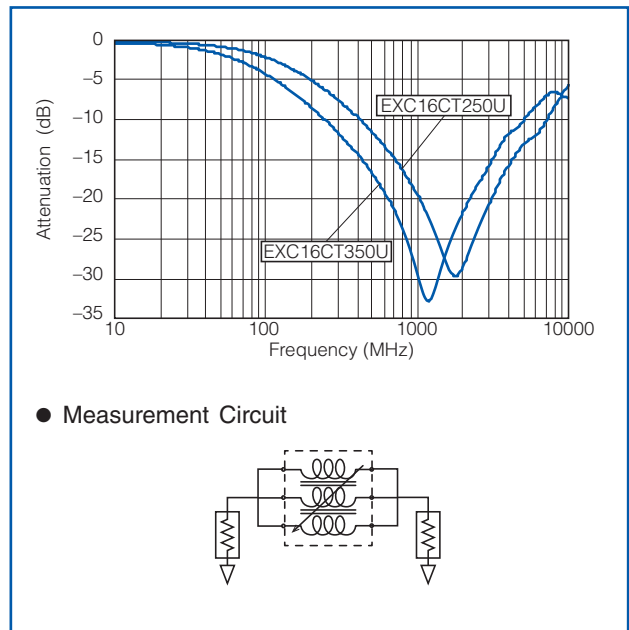

Differential Insertion Loss (Typical)

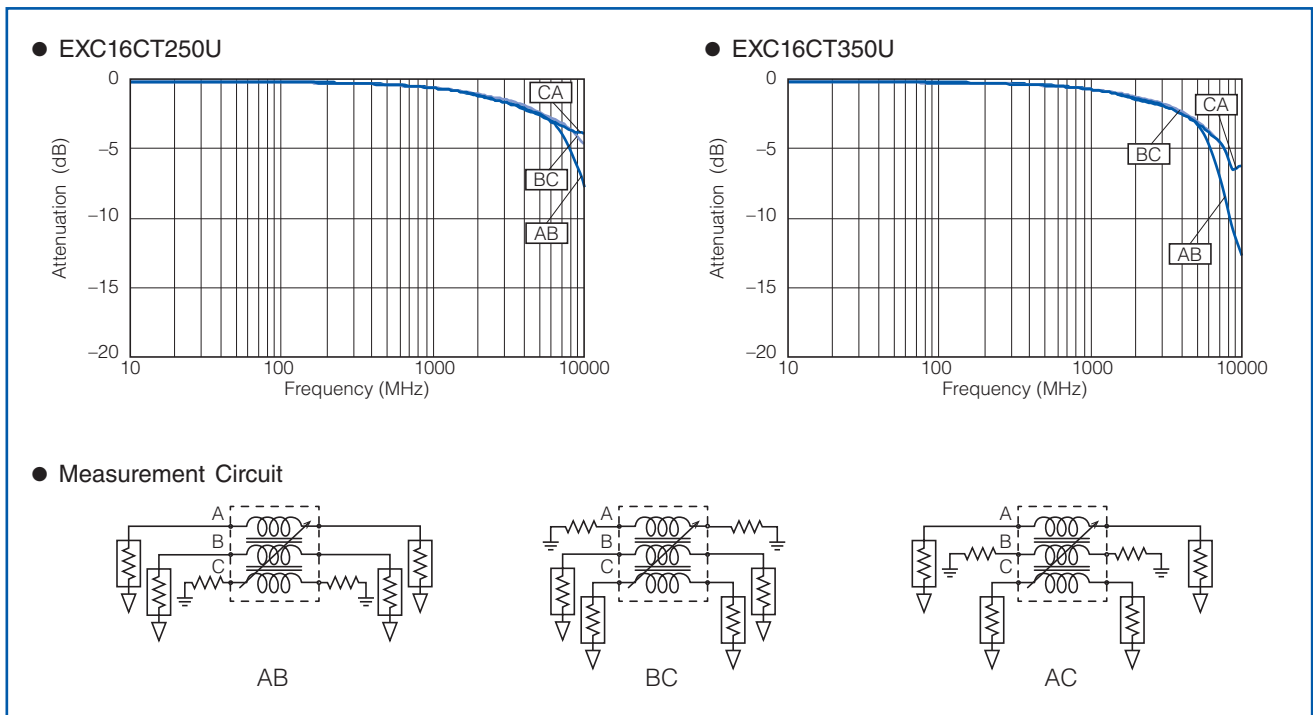

■ As for Packaging Methods, Land Pattern, Soldering Conditions and Safety Precautions, Please see Data Files

Common mode Noise Filters

Type: **EXC24CH**

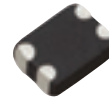

Features

- Small and thin type, built-in filter circuit (L 1.25 mm×W 1.00 mm×H 0.50 mm)
- Suppression of high frequency noise with little influence of waveform rounding on signal transmission, achieved by setting high cut-off frequency between 6 and 10 GHz
- Strong multilayer/sintered structure, excellent reflow resistance and high mounting reliability
- Lead, halogen and antimony-free
- RoHS compliant

Recommended Applications

- AV equipment (LCD-TV, DVD/Blu-ray drives), Information equipment (PCs, HDD), Communications equipment (Mobile phones, Smartphones)
- Noise suppression of high-speed differential data lines such as USB 3.0, HDMI and Display Port

Explanation of Part Numbers

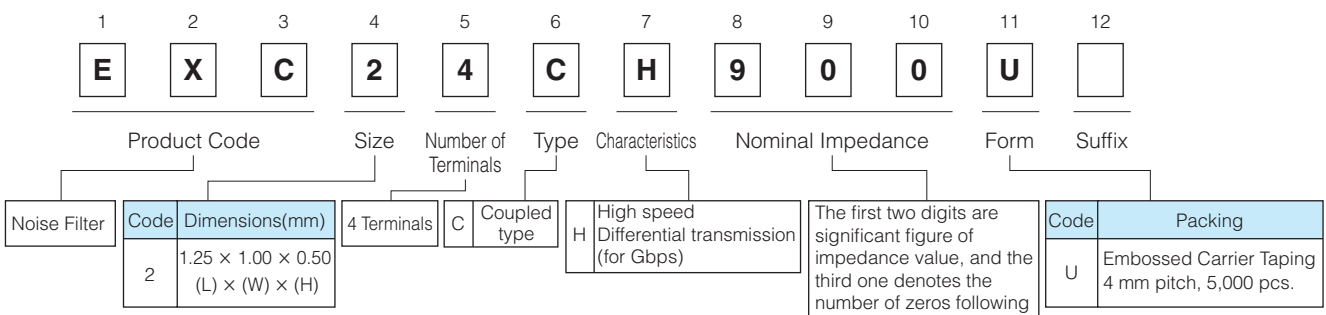

Construction

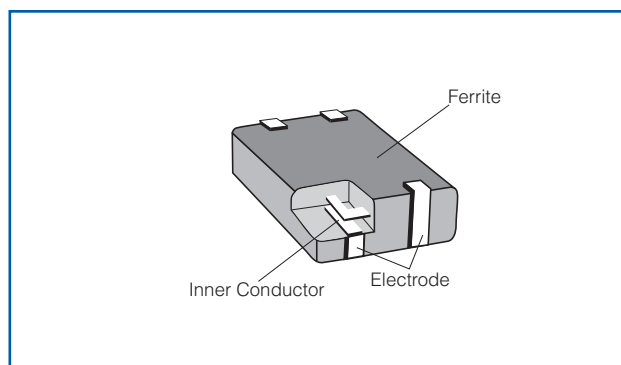

Dimensions in mm (not to scale)

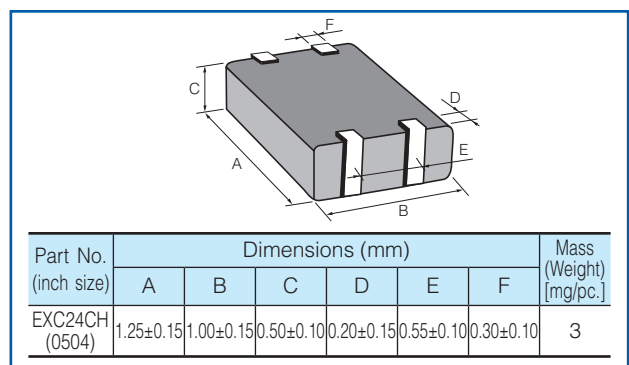

Circuit Configuration (No Polarity)

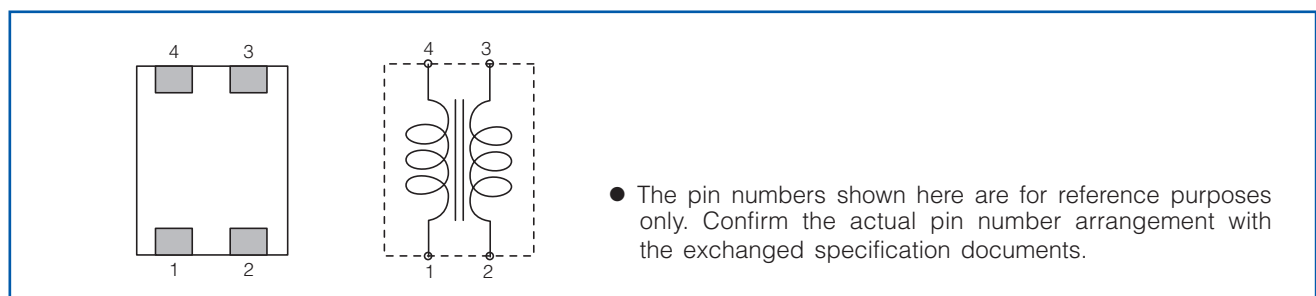

Ratings

Part Number	Impedance (Ω) at 100MHz		Cutoff Frequency (GHz)	Rated Voltage (V DC)	Rated Current (mA DC)	DC Resistance (Ω)max.
	Common Mode	Differential Mode				
EXC24CH500U	50 Ω \pm 25 %	13 Ω max.	10 Typ.	5	160	1.5
EXC24CH900U	90 Ω \pm 20 %	15 Ω max.	6 Typ.	5	130	2.5

- Category Temperature Range $-40\text{ }^{\circ}\text{C}$ to $+85\text{ }^{\circ}\text{C}$

Impedance Characteristics (Typical)

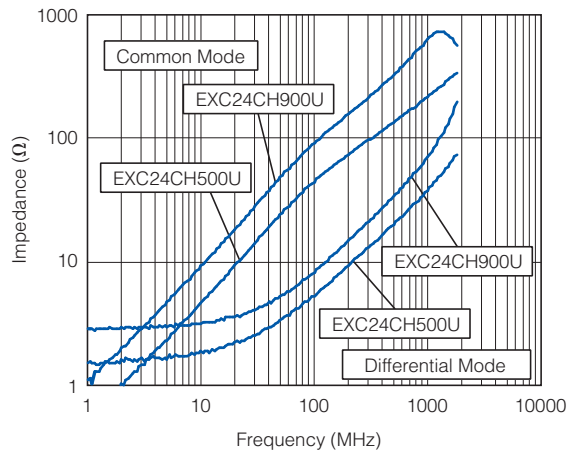

- Measurement Circuit

(A) Common Mode

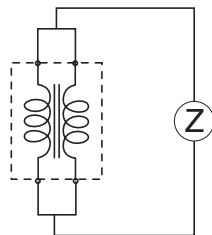

(B) Differential Mode

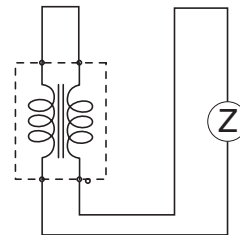

Insertion Loss (Typical)

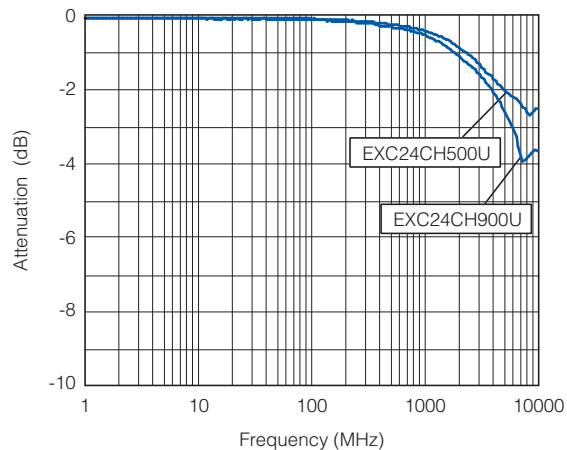

■ As for Packaging Methods, Land Pattern, Soldering Conditions and Safety Precautions, Please see Data Files

Common mode Noise Filters

Type: **EXC24CG**



Features

- Elimination of radiation noises from high-speed differential transmissions
- Prevention of reflection of transmission signals and noise radiation by controlling TDR characteristic impedance as 100 Ω
- Satisfaction of eye pattern standards of HDMI waveforms with capability to improve waveform fluctuations of skew and overshoot
- Simple multilayer structure, excellent mass productivity and high reliability
- Small and thin (L 1.25 mm×W 1.00 mm×H 0.50 mm)
- RoHS compliant

Recommended Applications

- AV equipment (LCD-TV, DVD/Blu-ray drives), Information equipment (PCs, HDD), Communications equipment (Mobile phones, Smartphones)
- Noise suppression of high-speed differential data lines such as HDMI, SATA and LAN

Explanation of Part Numbers

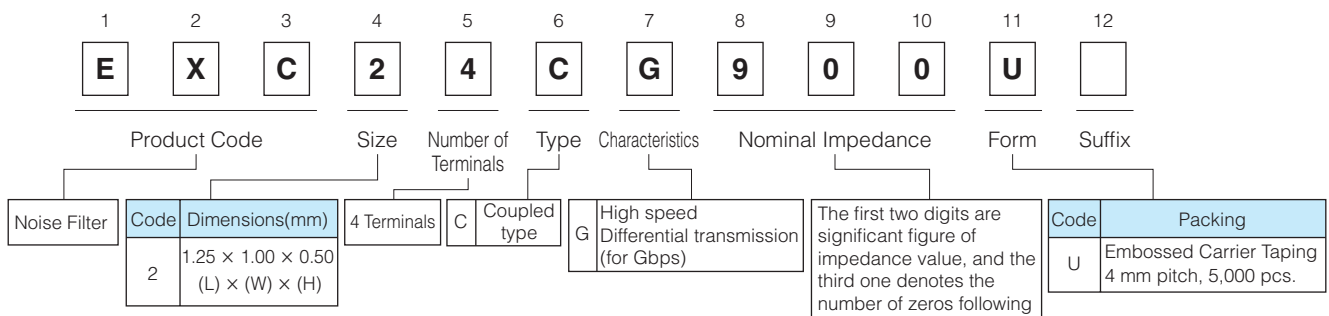

Construction

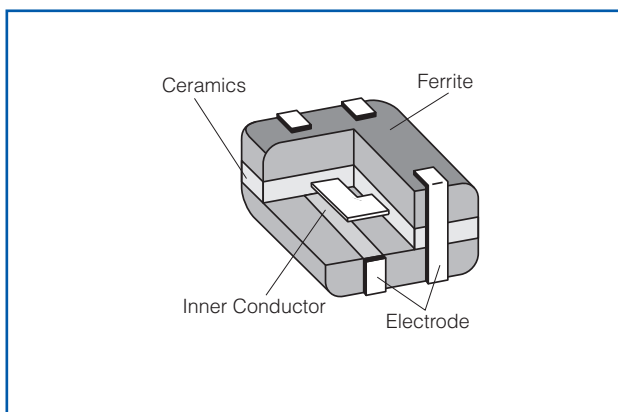

Dimensions in mm (not to scale)

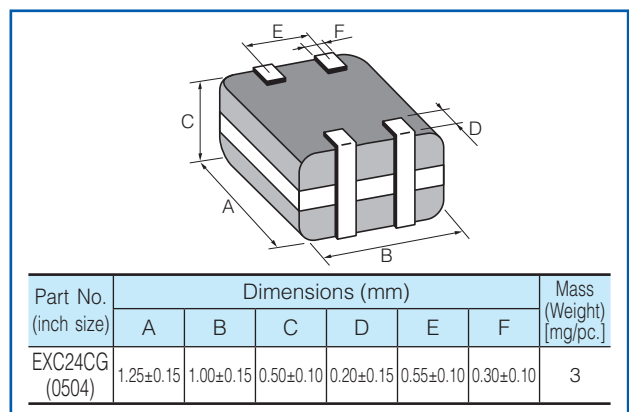

Circuit Configuration (No Polarity)

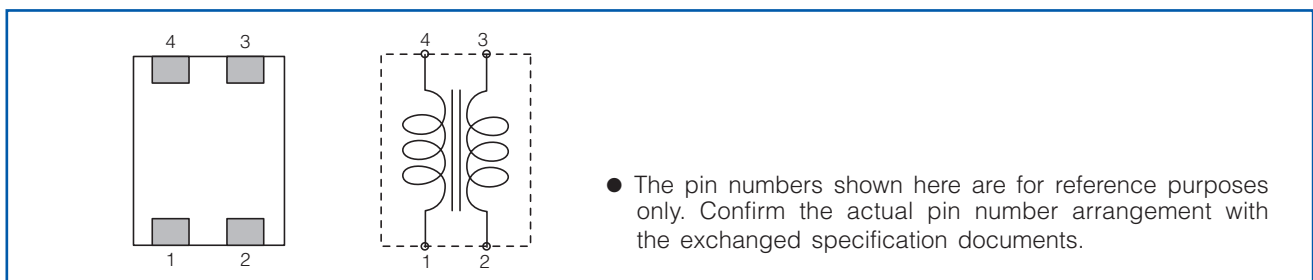

Ratings

Part Number	Impedance (Ω) at 100 MHz		Rated Voltage (V DC)	Rated Current (mA DC)	DC Resistance (Ω)max.
	Common Mode	Differential Mode			
EXC24CG240U	24 $\Omega \pm 25\%$	15 Ω max.	5	160	1.5
EXC24CG360U	36 $\Omega \pm 25\%$	15 Ω max.	5	130	1.7
EXC24CG900U	90 $\Omega \pm 25\%$	20 Ω max.	5	100	3.0

● Category Temperature Range $-40\text{ }^{\circ}\text{C}$ to $+85\text{ }^{\circ}\text{C}$

Impedance Characteristics (Typical)

● EXC24CG240U

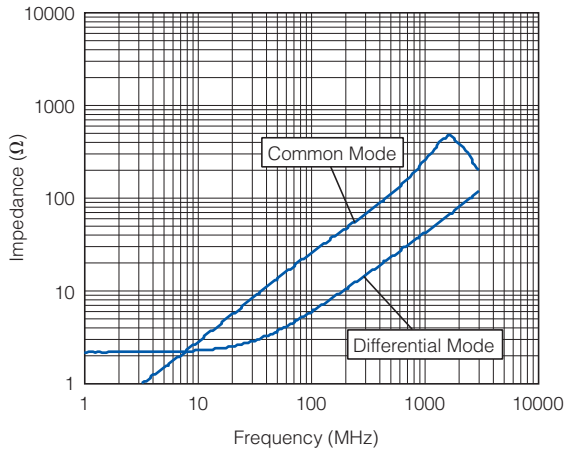

● EXC24CG360U

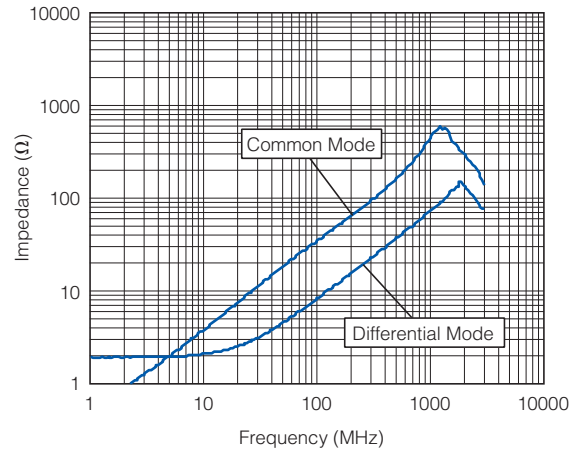

● EXC24CG900U

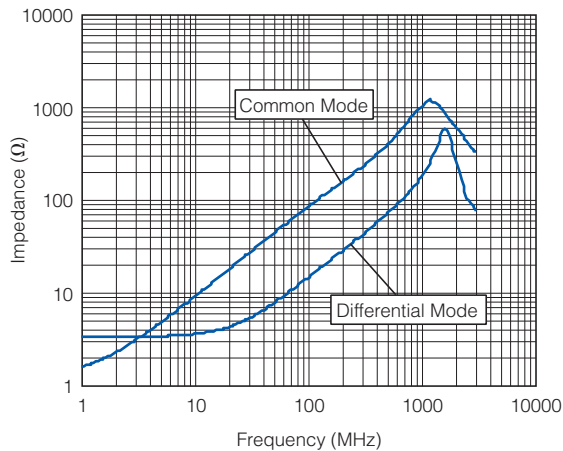

● Measurement Circuit

(A) Common Mode

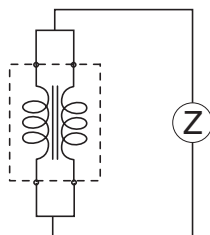

(B) Differential Mode

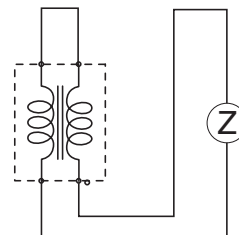

■ As for Packaging Methods, Land Pattern, Soldering Conditions and Safety Precautions, Please see Data Files

Common mode Noise Filters

Type: **EXC24CE**
EXC24CF



Features

- Elimination of radiation noises from high-speed differential transmissions
- Strong multilayer structure, excellent reflow resistance and high mounting reliability
- Magnetic shield type with no leakage
- High-Q impedance : EXC24CF
- Small and thin (L 1.25 mm×W 1.00 mm×H 0.50 mm)
- RoHS compliant

Recommended Applications

- AV equipment (LCD-TV, DVD/Blu-ray drives), Information equipment (PCs, HDD, Printers), Communications equipment (Mobile phones, Smartphones)
- Noise suppression of high-speed differential data lines such as USB2.0 and LVDS

Explanation of Part Numbers

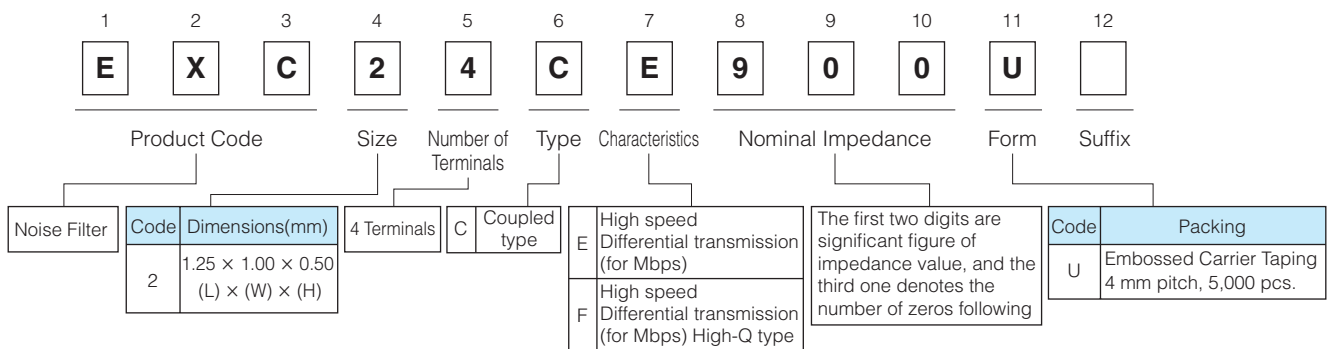

Construction

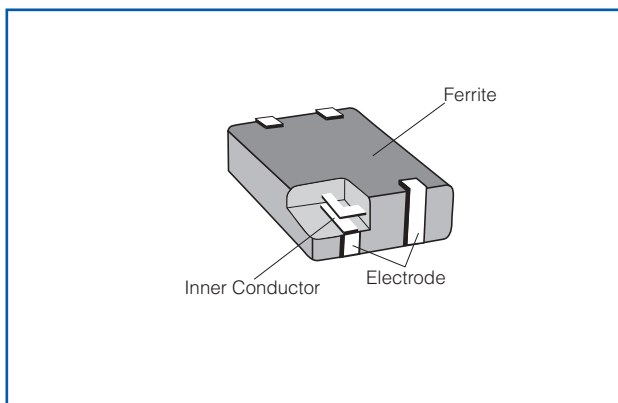

Dimensions in mm (not to scale)

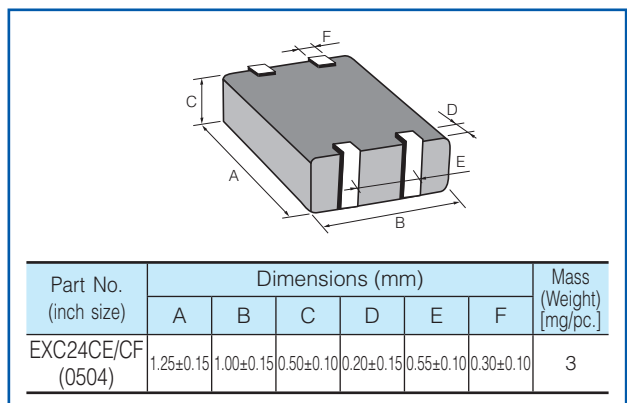

Circuit Configuration (No Polarity)

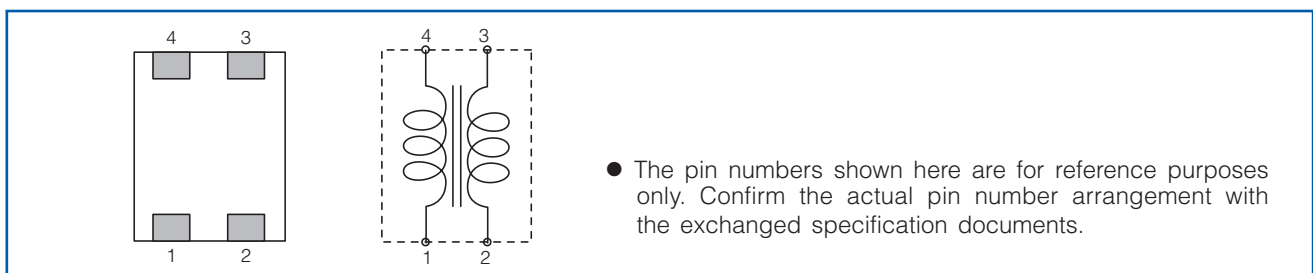

Ratings

Part Number	Impedance (Ω) at 100 MHz		Rated Voltage (V DC)	Rated Current (mA DC)	DC Resistance (Ω)max.
	Common Mode	Differential Mode			
EXC24CE360UP	36 $\Omega \pm 25\%$	20 Ω max.	5	200	1.0
EXC24CE900U	90 $\Omega \pm 25\%$	15 Ω max.	5	160	1.75
EXC24CE121U	120 $\Omega \pm 25\%$	18 Ω max.	5	140	2.2
EXC24CE201U	200 $\Omega \pm 25\%$	20 Ω max.	5	130	2.7
EXC24CF900U	90 $\Omega \pm 25\%$	20 Ω max.	5	130	2.5

- Category Temperature Range $-40\text{ }^{\circ}\text{C}$ to $+85\text{ }^{\circ}\text{C}$

Impedance Characteristics (Typical)

● EXC24CE360UP

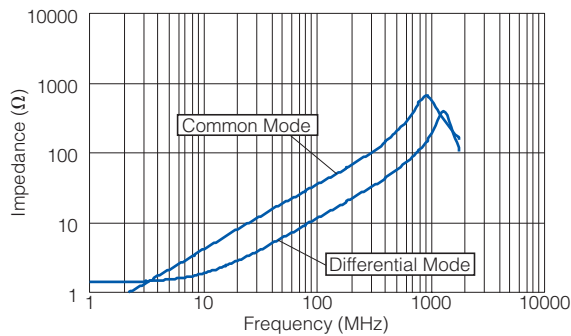

● EXC24CE900U

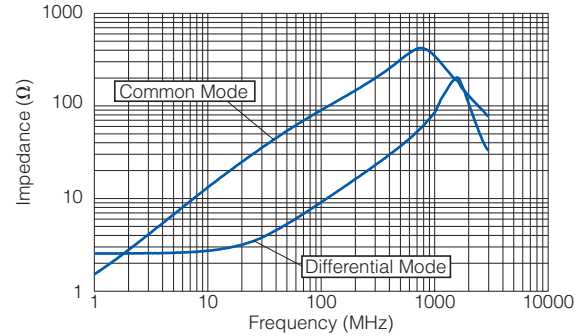

● EXC24CE121U

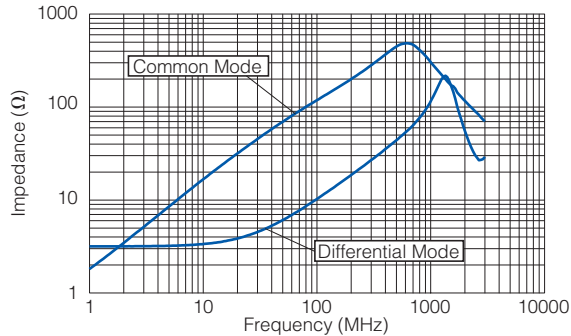

● EXC24CE201U

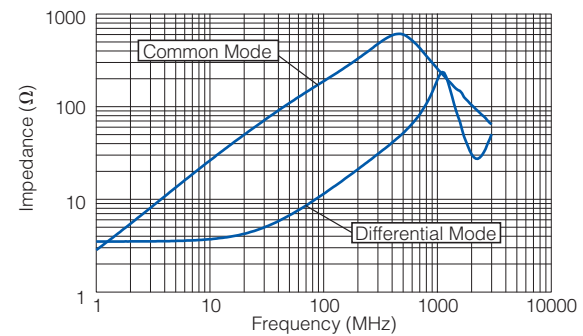

● EXC24CF900U

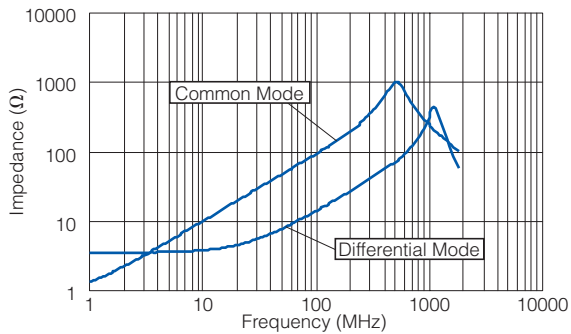

● Measurement Circuit

(A) Common Mode

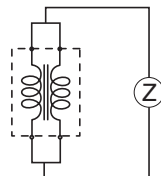

(B) Differential Mode

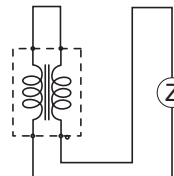

■ As for Packaging Methods, Land Pattern, Soldering Conditions and Safety Precautions, Please see Data Files

Common mode Noise Filters

Type: **EXC34CG/CE**



Features

- Thin type, built-in filter circuit (L 2.0 mm×W 1.25 mm×H 0.50 mm)
- Noise suppression of high-speed differential transmission lines with little influence of waveform rounding on signal transmission
- Strong multilayer/sintered structure, excellent reflow resistance and high mounting reliability
- Lead, halogen and antimony-free
- RoHS compliant

Recommended Applications

- AV equipment (LCD-TV, DVD/Blu-ray drives), Information equipment (PCs, HDD, Printers)
- Noise suppression of high-speed differential data lines such as USB2.0, LVDS, HDMI and LAN

Explanation of Part Numbers

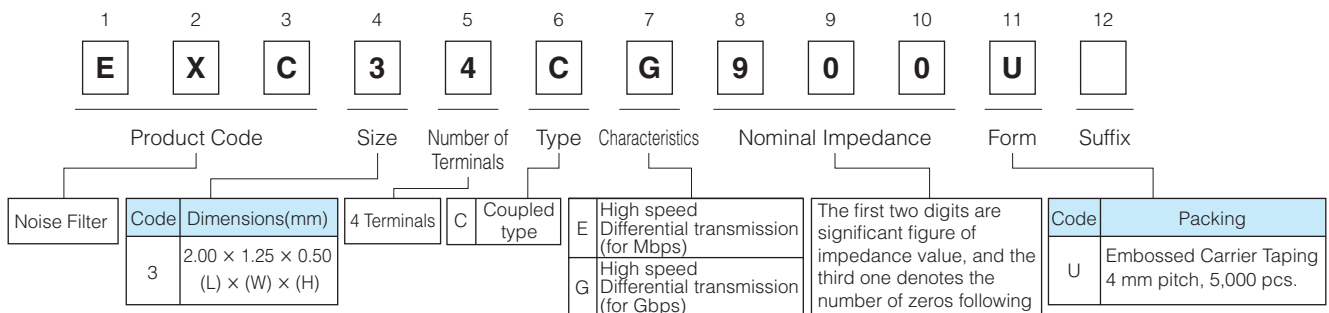

Construction

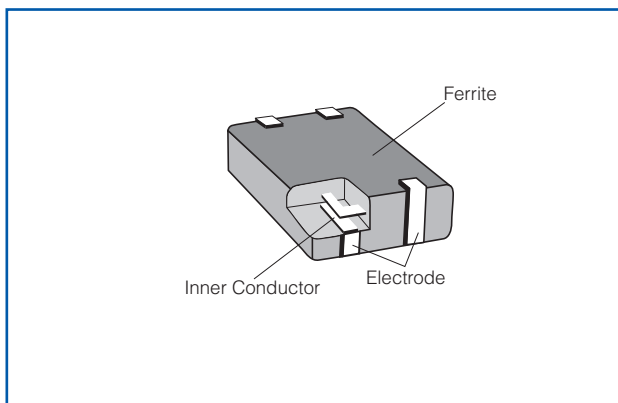

Dimensions in mm (not to scale)

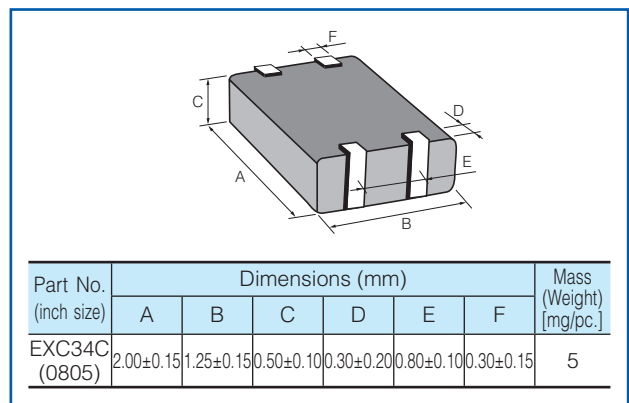

Circuit Configuration (No Polarity)

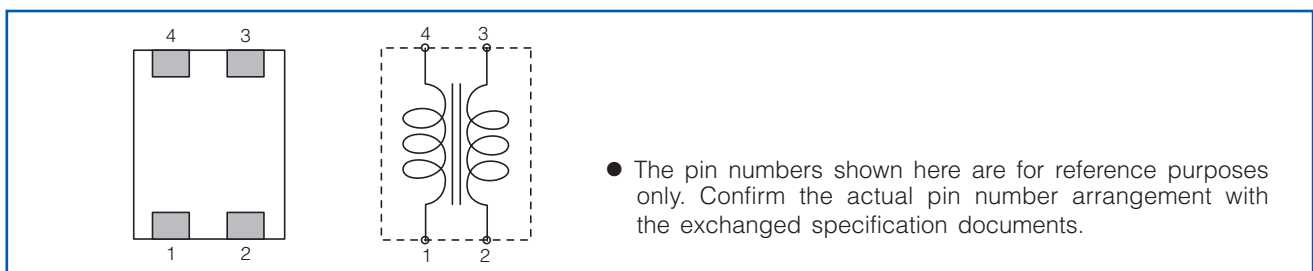

Ratings

Part Number	Impedance (Ω) at 100MHz	Rated Current (mA DC)	Rated Voltage (V DC)	Insulation Resistance ($M\Omega$ min.)	Withstand Voltage (V DC)	DC Resistance (Ω)max.
	Common Mode					
EXC34CE670U	67 $\Omega \pm 25\%$	250	5	10 $M\Omega$	125	0.8
EXC34CE900U	90 $\Omega \pm 25\%$	250	5	10 $M\Omega$	125	0.8
EXC34CE121U	120 $\Omega \pm 25\%$	200	5	10 $M\Omega$	125	1.0
EXC34CE201U	200 $\Omega \pm 25\%$	200	5	10 $M\Omega$	125	1.0
EXC34CG900U	90 $\Omega \pm 25\%$	100	5	10 $M\Omega$	125	3.0

● Category Temperature Range $-40\text{ }^{\circ}\text{C}$ to $+85\text{ }^{\circ}\text{C}$

Impedance Characteristics (Typical)

● EXC34CE670U

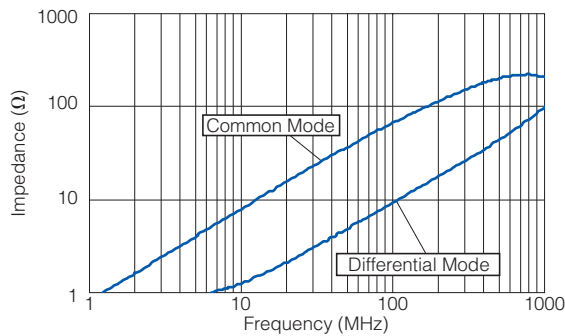

● EXC34CE900U

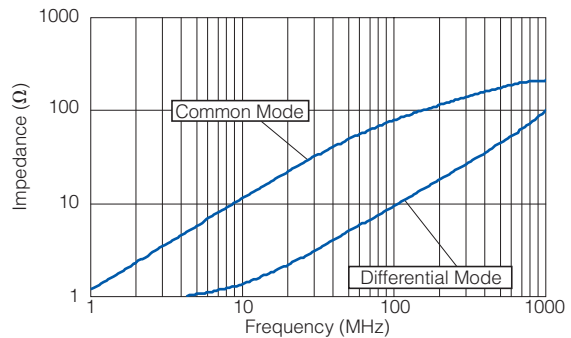

● EXC34CE121U

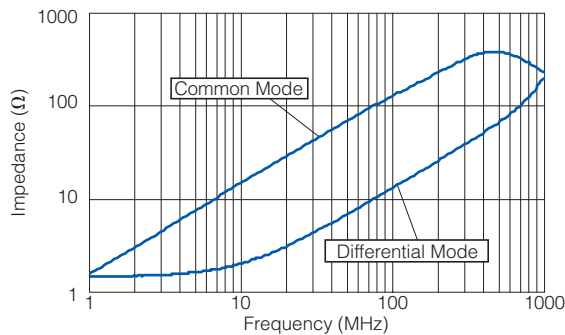

● EXC34CE201U

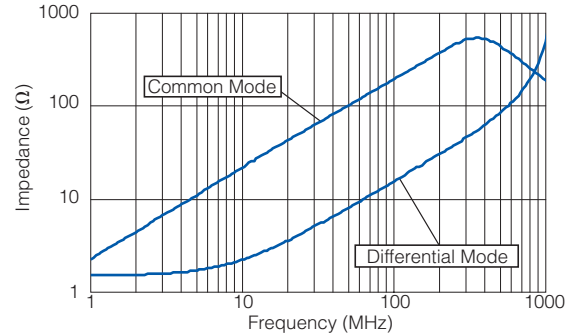

● EXC34CG900U

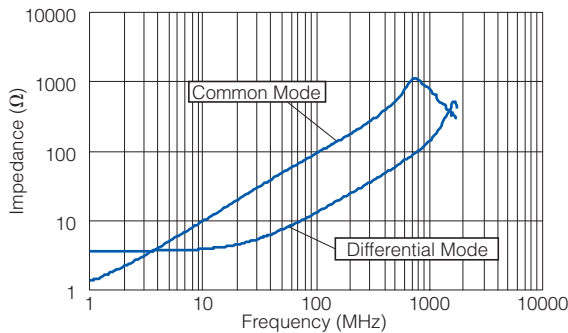

● Measurement Circuit

(A) Common Mode

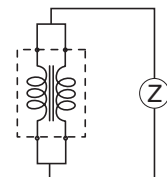

(B) Differential Mode

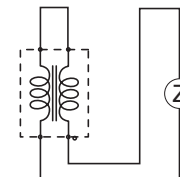

■ As for Packaging Methods, Land Pattern, Soldering Conditions and Safety Precautions, Please see Data Files

Common mode Noise Filter Array

Type: **EXC18CG**
EXC18CE



Features

- Small and thin type, two built-in filter circuit (L 1.6 mm×W 0.8 mm×H 0.4 mm)
- Noise suppression of high-speed differential transmission lines with little influence of waveform rounding on signal transmission
- Low DC resistance and low insertion loss
- High-Q value and high impedance of GHz zone : EXC18CG type
- Strong multilayer/sintered structure, excellent reflow resistance and high mounting reliability
- Lead, halogen and antimony-free
- RoHS compliant

Recommended Applications

- AV equipment (LCD-TV, DVD/Blu-ray drives), Information equipment (PCs, HDD, Printers)
- Noise suppression of high-speed differential data lines such as USB2.0, LVDS, HDMI and LAN

Explanation of Part Numbers

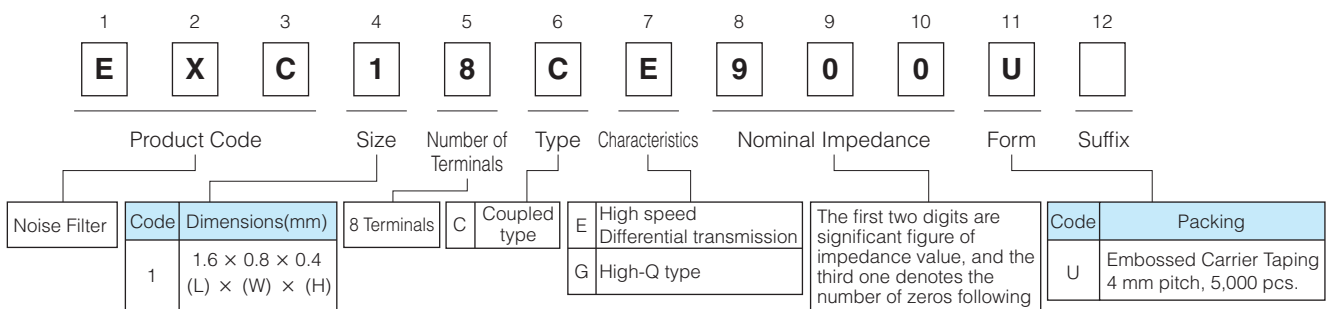

Construction

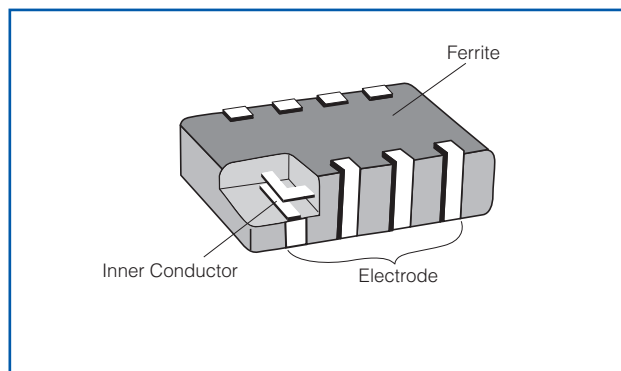

Dimensions in mm (not to scale)

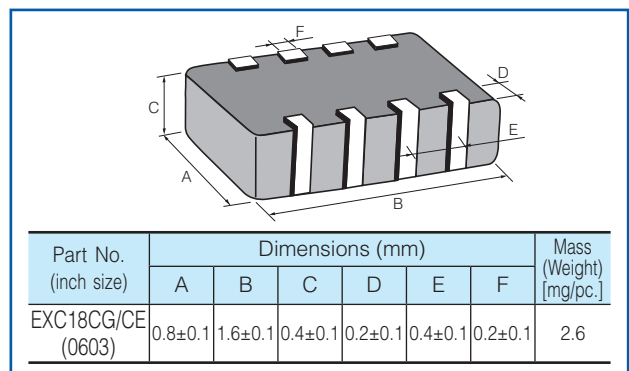

Circuit Configuration (No Polarity)

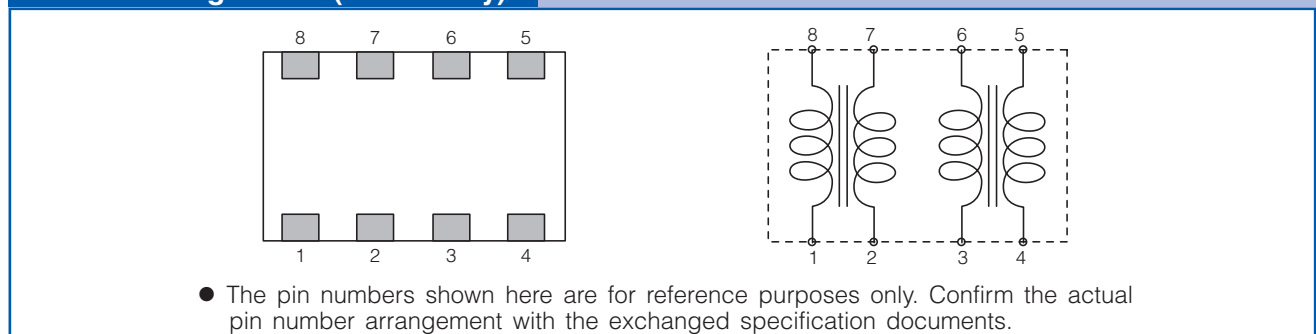

Ratings

Part Number	Impedance (Ω) at 100 MHz		Rated Voltage (V DC)	Rated Current (mA DC)	DC Resistance (Ω)max.
	Common Mode	Differential Mode			
EXC18CG430U	43 Ω \pm 25 %	15 Ω max.	5	100	2.7
EXC18CE650U	65 Ω \pm 20 %	18 Ω max.	5	140	1.8
EXC18CE900U	90 Ω \pm 20 %	20 Ω max.	5	130	2.0
EXC18CE201U	200 Ω \pm 20 %	22 Ω max.	5	100	3.5

● Category Temperature Range $-40\text{ }^{\circ}\text{C}$ to $+85\text{ }^{\circ}\text{C}$

Impedance Characteristics (Typical)

● EXC18CG430U

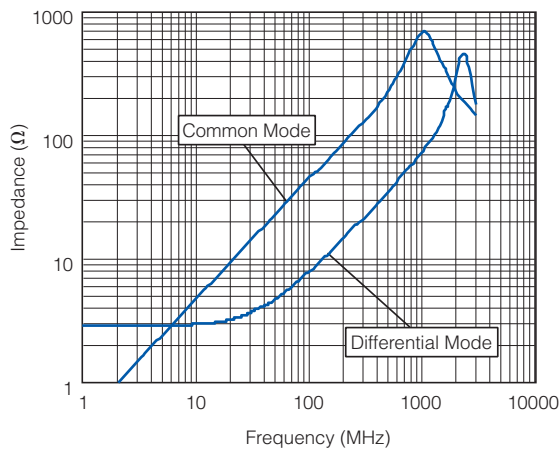

● EXC18CE650U

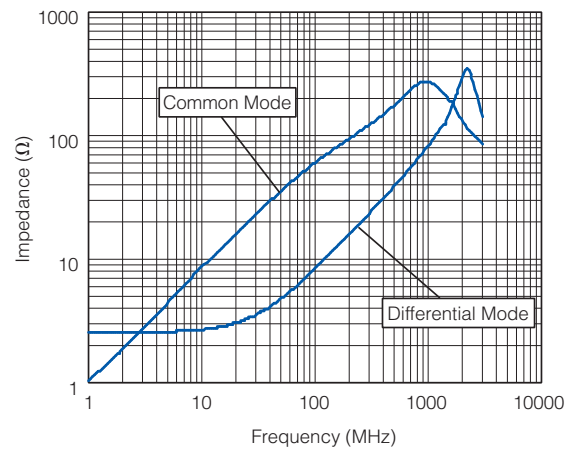

● EXC18CE900U

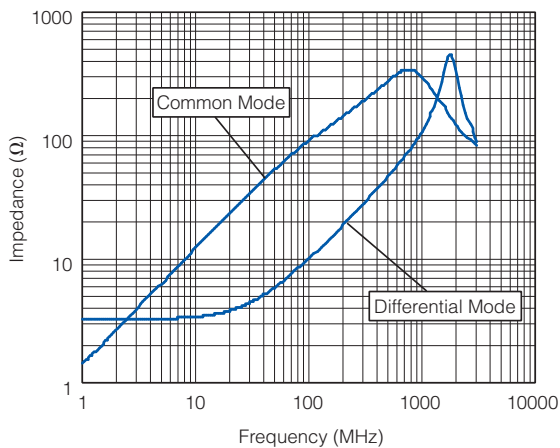

● EXC18CE201U

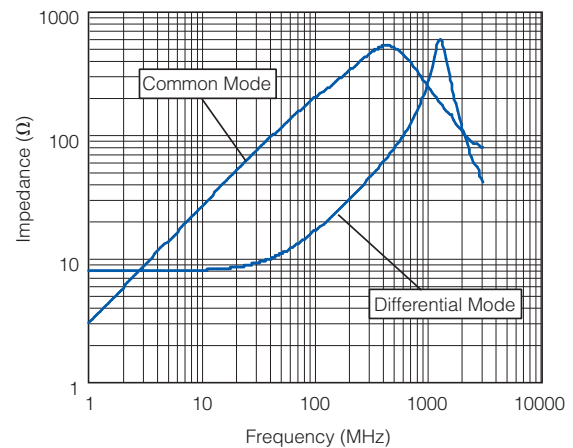

● Measurement Circuit

(A) Common Mode

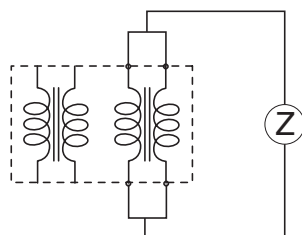

(B) Differential Mode

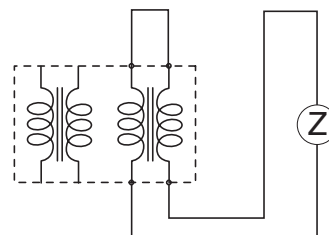

■ As for Packaging Methods, Land Pattern, Soldering Conditions and Safety Precautions, Please see Data Files

Common mode Noise Filter Array

Type: **EXC28CH**



Features

- Small and thin type, two built-in filter circuit (L 2.0 mm×W 1.0 mm×H 0.5 mm)
- Suppression of high frequency noise with little influence of waveform rounding on signal transmission, achieved by setting high cut-off frequency between 6 and 10 GHz
- Strong multilayer/sintered structure, excellent reflow resistance and high mounting reliability
- Lead, halogen and antimony-free
- RoHS compliant

Recommended Applications

- AV equipment (LCD-TV, DVD/Blu-ray drives), Information equipment (PCs, HDD, Printers)
- Noise suppression of high-speed differential data lines such as USB3.0, LVDS, HDMI and LAN

Explanation of Part Numbers

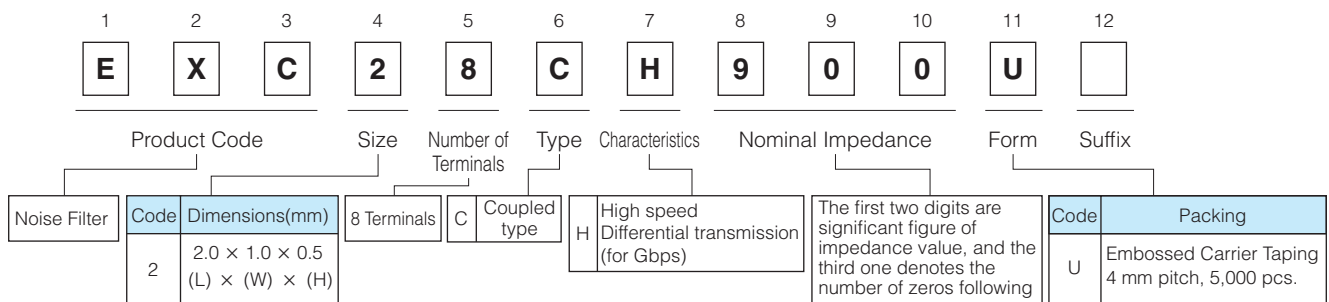

Construction

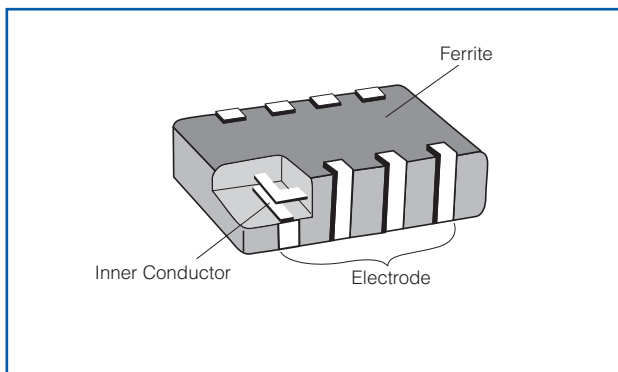

Dimensions in mm (not to scale)

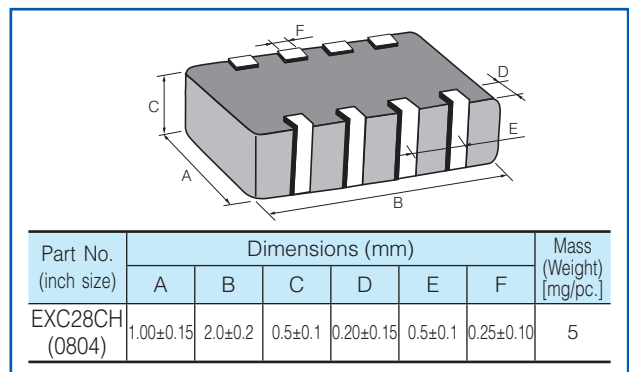

Circuit Configuration (No Polarity)

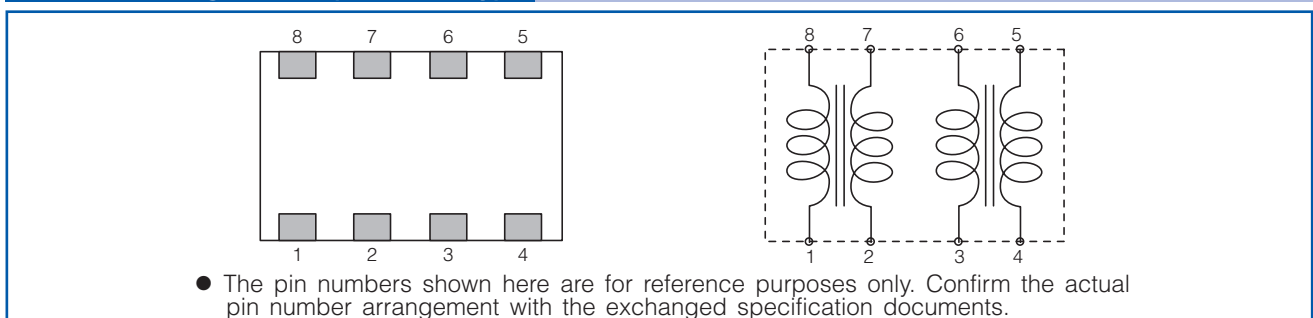

Ratings

Part Number	Impedance (Ω) at 100 MHz		Cutoff Frequency (GHz)	Rated Voltage (V DC)	Rated Current (mA DC)	DC Resistance (Ω)max.
	Common Mode	Differential Mode				
EXC28CH500U	50 $\Omega \pm 25\%$	13 Ω max.	10 Typ.	5	160	1.5
EXC28CH900U	90 $\Omega \pm 20\%$	15 Ω max.	6 Typ.	5	130	2.5

- Category Temperature Range $-40\text{ }^{\circ}\text{C}$ to $+85\text{ }^{\circ}\text{C}$

Impedance Characteristics (Typical)

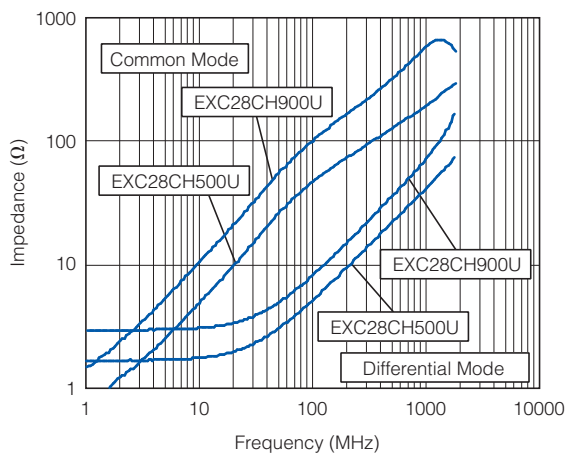

- Measurement Circuit

(A) Common Mode

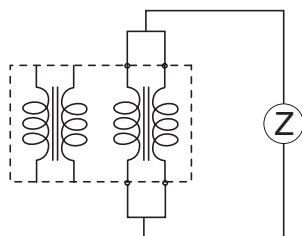

(B) Differential Mode

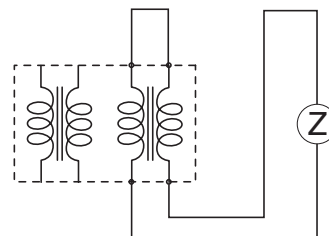

Insertion Loss (Typical)

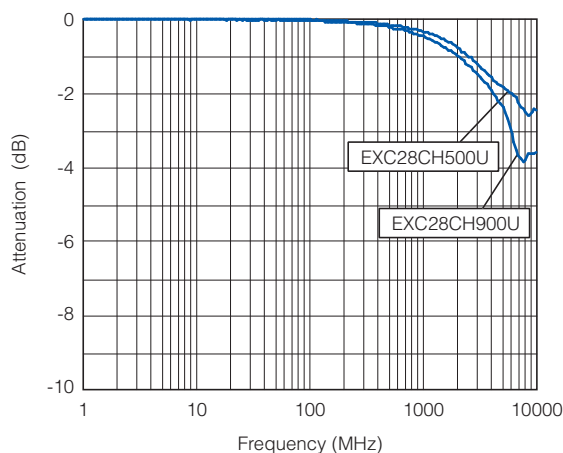

■ As for Packaging Methods, Land Pattern, Soldering Conditions and Safety Precautions, Please see Data Files

Common mode Noise Filter Array

Type: **EXC28CG**



Features

- Small and thin type, two built-in filter circuit (L 2.0 mm×W 1.0 mm×H 0.5 mm)
- Prevention of weakening of transmission signals by controlling signal pass band as 3 GHz or above
- Prevention of reflection of transmission signals and noise radiation by controlling TDR characteristic impedance as 100 Ω
- Satisfaction of eye pattern standards of HDMI waveforms with capability to improve waveform fluctuations of Jitter and phase shift etc
- Elimination of radiation noises from high-speed differential transmissions
- Magnetic shield type with no leakage
- RoHS compliant

Recommended Applications

- AV equipment (LCD-TV, DVD/Blu-ray drives), Information equipment (PCs, HDD), Communications equipment (Mobile phones, Smartphones)
- Noise suppression of high-speed differential data lines such as HDMI, SATA and LAN

Explanation of Part Numbers

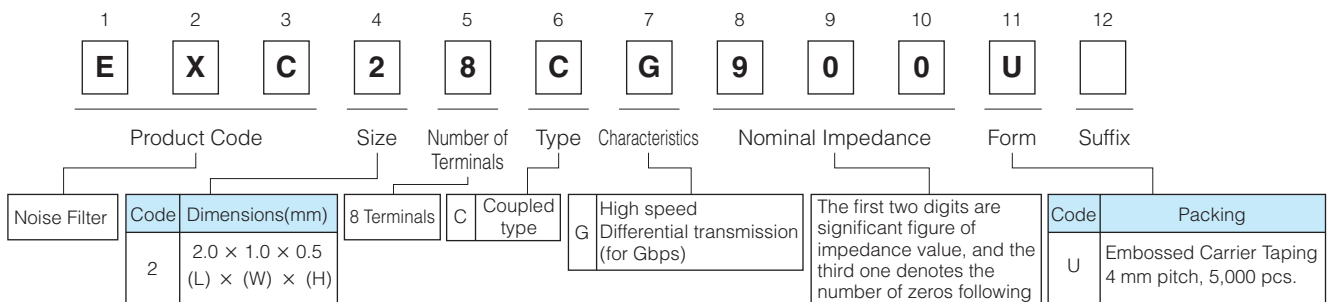

Construction

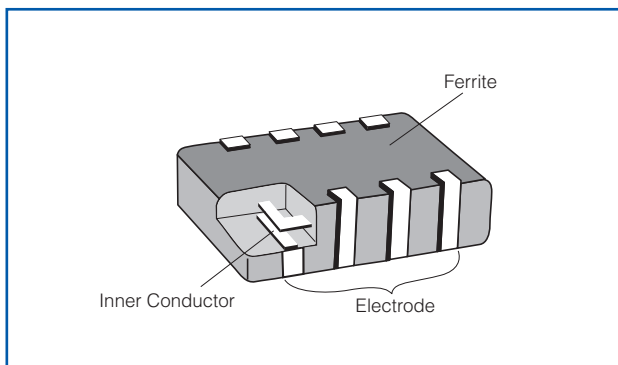

Dimensions in mm (not to scale)

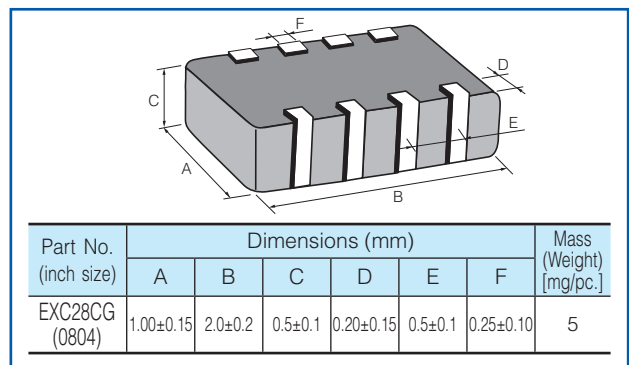

Circuit Configuration (No Polarity)

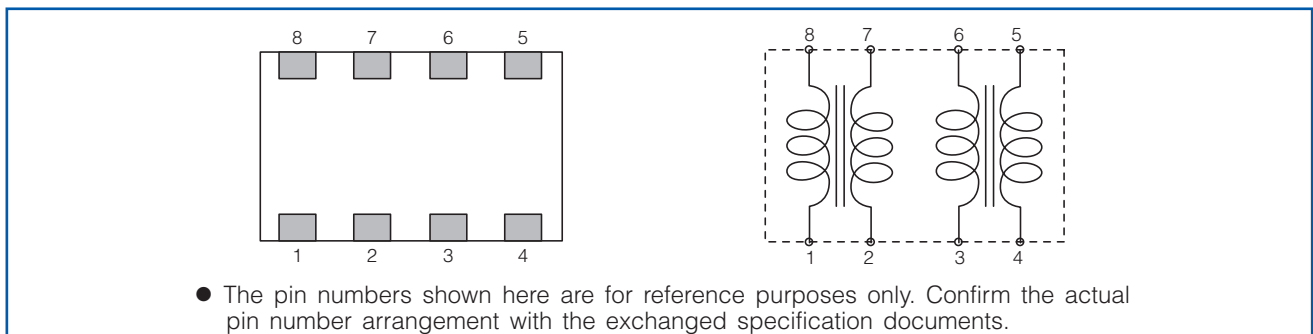

Ratings

Part Number	Impedance (Ω) at 100 MHz		Rated Voltage (V DC)	Rated Current (mA DC)	DC Resistance (Ω)max.
	Common Mode	Differential Mode			
EXC28CG240U	24 Ω \pm 25 %	15 Ω max.	5	160	1.5
EXC28CG900U	90 Ω \pm 25 %	17 Ω max.	5	130	3.0

- Category Temperature Range -40 °C to $+85$ °C

Impedance Characteristics (Typical)

● EXC28CG240U

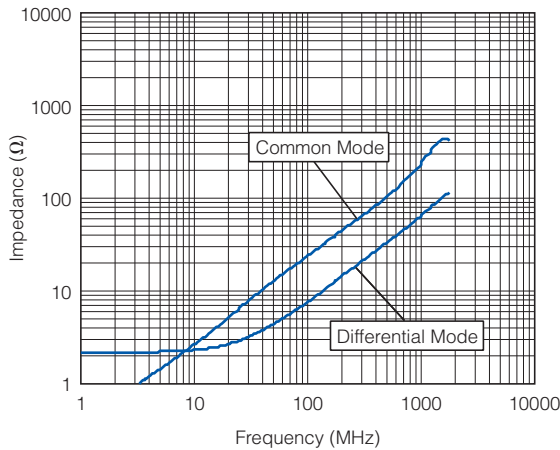

● EXC28CG900U

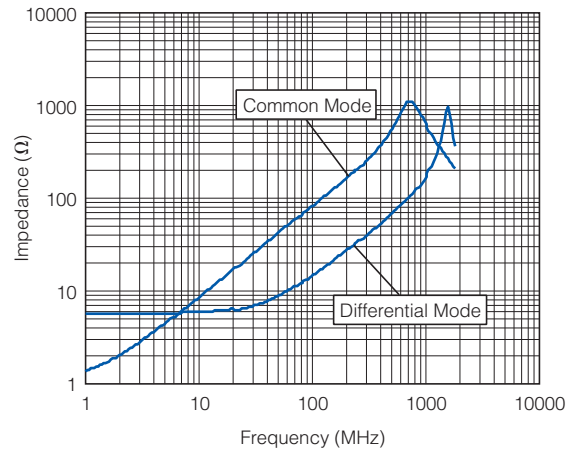

● Measurement Circuit

(A) Common Mode

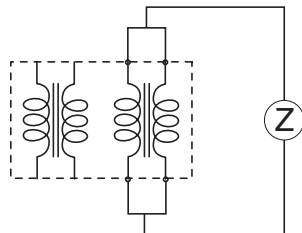

(B) Differential Mode

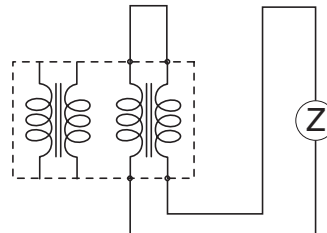

- As for Packaging Methods, Land Pattern, Soldering Conditions and Safety Precautions, Please see Data Files

Common mode Noise Filter Array

Type: **EXC28CE**



Features

- Small and thin type, two built-in filter circuit (L 2.0 mm×W 1.0 mm×H 0.5 mm)
- Elimination of radiation noises from high-speed differential transmissions
- Magnetic shield type with no leakage
- Strong multilayer/sintered structure, excellent reflow resistance and high mounting reliability
- Lead, halogen and antimony-free
- RoHS compliant

Recommended Applications

- AV equipment (LCD-TV, DVD/Blu-ray drives), Information equipment (PCs, HDD, Printers), Communications equipment (Mobile phones, Smartphones)
- Noise suppression of high-speed differential data lines such as USB2.0 and LVDS

Explanation of Part Numbers

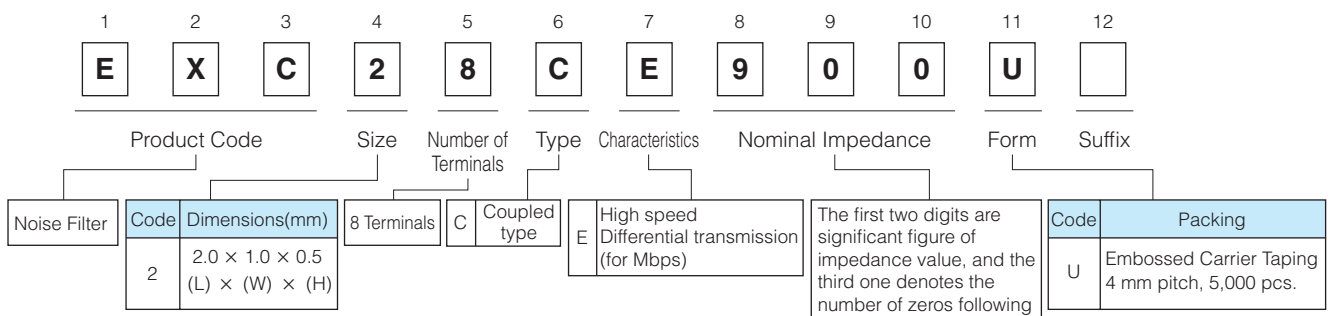

Construction

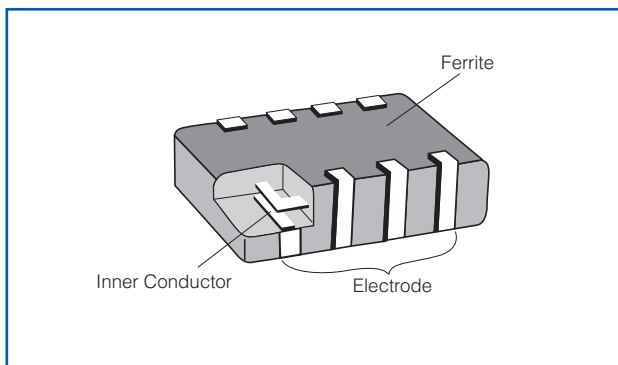

Dimensions in mm (not to scale)

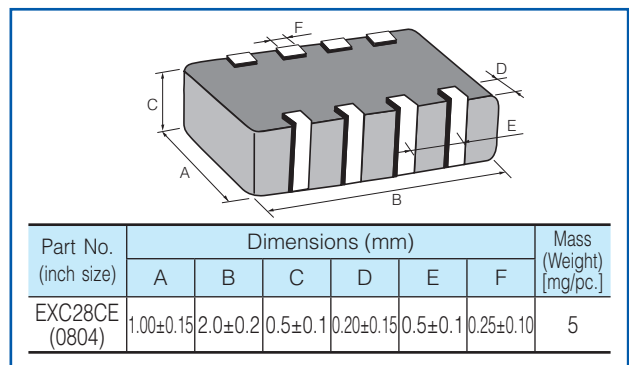

Circuit Configuration (No Polarity)

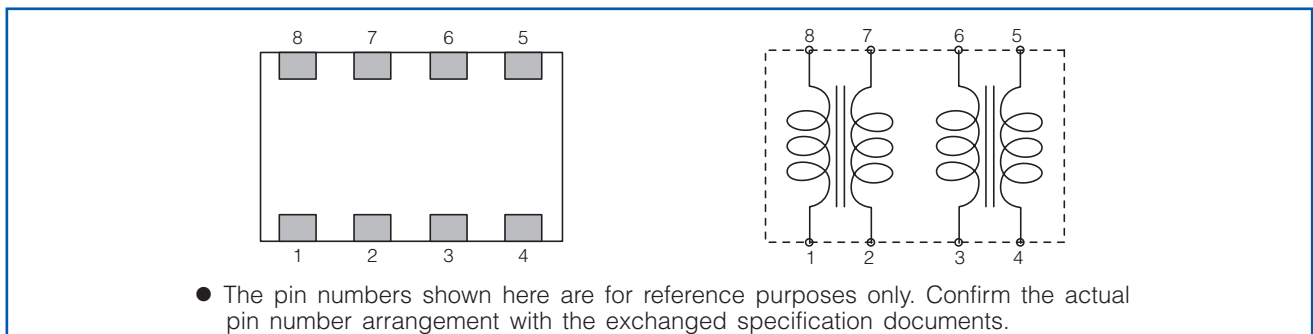

Ratings

Part Number	Impedance (Ω) at 100 MHz		Rated Voltage (V DC)	Rated Current (mA DC)	DC Resistance (Ω) max.
	Common Mode	Differential Mode			
EXC28CE900U	90 $\Omega \pm 25\%$	15 Ω max.	5	160	1.5
EXC28CE121U	120 $\Omega \pm 25\%$	18 Ω max.	5	140	2.0
EXC28CE201U	200 $\Omega \pm 25\%$	20 Ω max.	5	130	2.5

- Category Temperature Range $-40\text{ }^{\circ}\text{C}$ to $+85\text{ }^{\circ}\text{C}$

Impedance Characteristics (Typical)

● EXC28CE900U

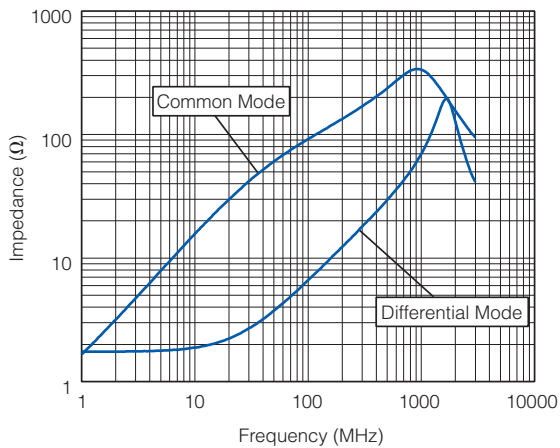

● EXC28CE121U

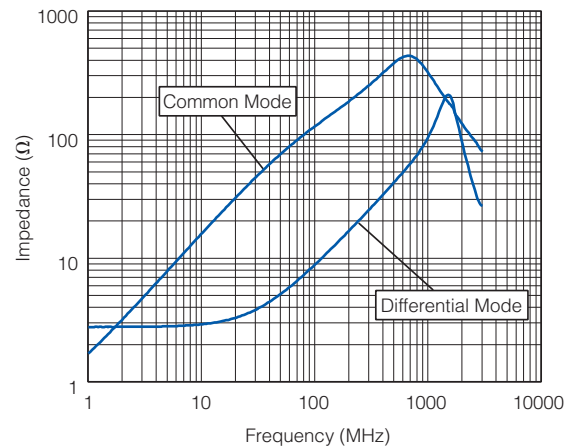

● EXC28CE201U

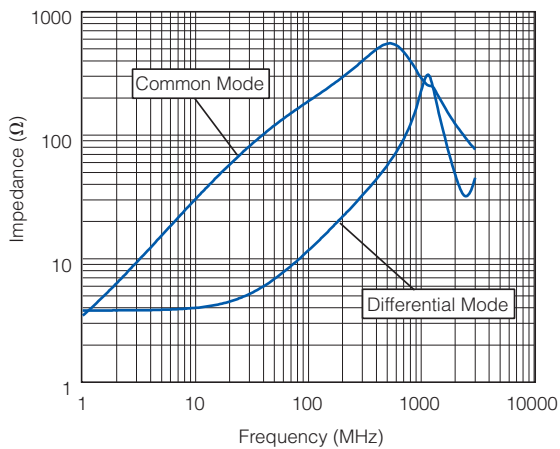

● Measurement Circuit

(A) Common Mode

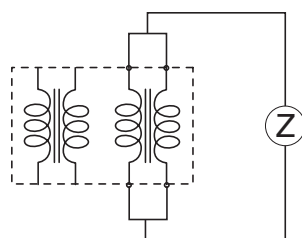

(B) Differential Mode

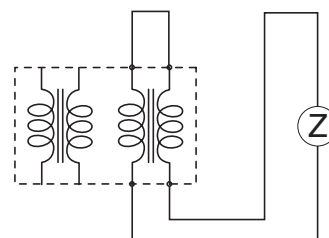

■ **As for Packaging Methods, Land Pattern, Soldering Conditions and Safety Precautions,**
Please see Data Files

Packaging Methods (Taping)

- Standard Quantity

Part Number	Size (inch)	Type	Kind of Taping	Pitch (P ₁)	Quantity
EXCX4C	0202	Single	Pressed Carrier Taping	2 mm	10,000 pcs./reel
EXC14C	0302				
EXC16C	0403		Embossed Carrier Taping	4 mm	5,000 pcs./reel
EXC24C	0504				
EXC34C	0805				
EXC18C	0603	Array	Embossed Carrier Taping	4 mm	5,000 pcs./reel
EXC28C	0804				

- Pressed Carrier Taping
EXCX4C

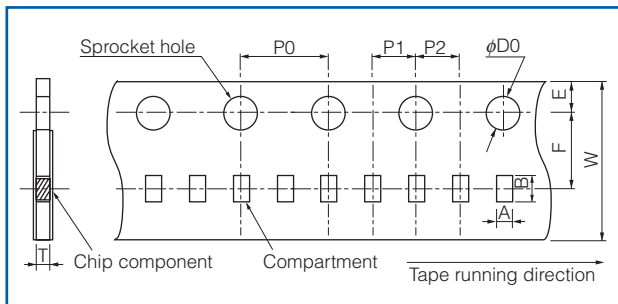

- Embossed Carrier Taping
EXC14C, 16C

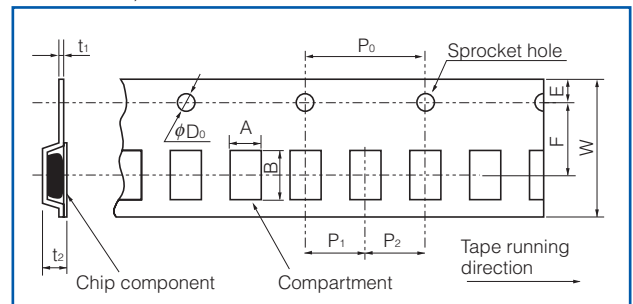

- Embossed Carrier Taping
EXC18C, 24C, 28C, 34C

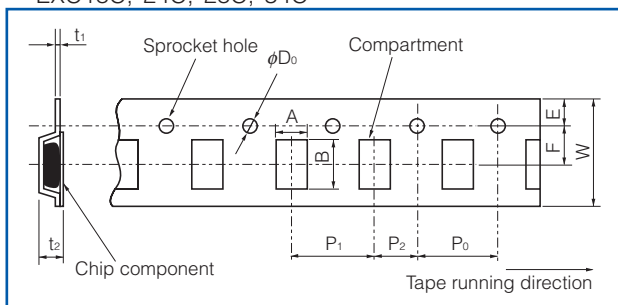

- Taping Reel

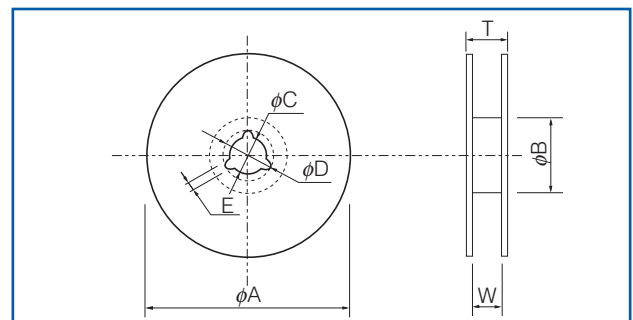

- Pressed Carrier Taping

(mm)

Part Number	A	B	W	F	E	P ₁	P ₂	P ₀	φD ₀	T
EXCX4C	0.60±0.10	0.80±0.10	8.0±0.2	3.50±0.05	1.75±0.10	2.0±0.1	2.0±0.1	4.0±0.1	1.5 ^{+0.1} ₀	0.35 typ.

- Embossed Carrier Taping

(mm)

Part Number	A	B	W	F	E	P ₁	P ₂	P ₀	φD ₀	t ₁	t ₂
EXC14C	0.75±0.10	0.95±0.10	8.0±0.2	3.50±0.05	1.75±0.10	2.0±0.1	2.0±0.1	4.0±0.1	1.5 ^{+0.1} ₀	0.25±0.05	0.85±0.15
EXC16C	0.77±0.10	0.99±0.10									0.80±0.15
EXC18C	1.00±0.10	1.80±0.10	8.0±0.2	3.5±0.1	1.75±0.10	4.0±0.1	2.0±0.1	4.0±0.1	1.5 ^{+0.1} ₀	0.25±0.05	0.80±0.05
EXC24C	1.20±0.15	1.45±0.15									0.90±0.15
EXC28C	1.20±0.15	2.25±0.15									
EXC34C	1.50±0.20	2.30±0.20									

- Taping Reel

Standard Reel Dimensions

(mm)

Part Number	φA	φB	φC	φD	E	W	T
EXCX4C	180.0±3.0	60.0±1.0	13.0±0.2	21.0±0.8	2.0±0.5	9.0±0.3	11.4±1.0
EXC14C			13.0±0.5				11.4±1.5
EXC16C							
EXC18C							
EXC24C							
EXC28C							
EXC34C							

Recommended Land Pattern Design

● Single

EXCX4C, 14C, 24C, 34C

EXC16C

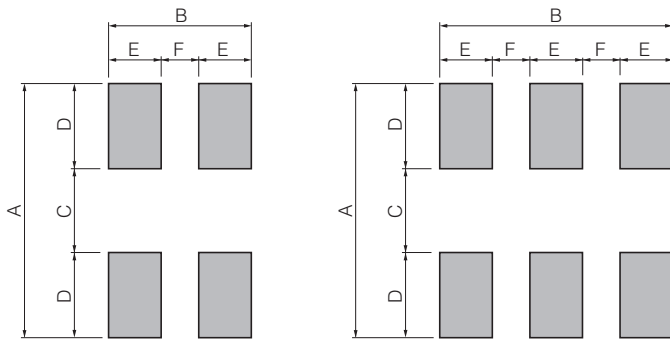

Part Number	Dimensions (mm)					
	A	B	C	D	E	F
EXCX4C	0.80 to 0.90	0.60 to 0.75	0.20 to 0.30	0.30	0.20 to 0.25	0.20 to 0.25
EXC14C	0.80 to 1.00	0.80	0.30	0.25 to 0.35	0.30	0.20
EXC24C	1.60 to 2.00	0.95	0.70	0.45 to 0.65	0.35	0.25
EXC34C	2.60	1.20	1.10	0.75	0.40	0.40
EXC16C	0.99	0.85	0.33	0.33	0.15	0.20

● Array

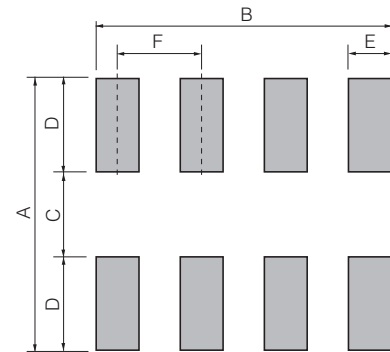

Part Number	Dimensions (mm)					
	A	B	C	D	E	F
EXC18C	1.4	1.4	0.4	0.5	0.2	0.4
EXC28C	1.4	1.75	0.4	0.5	0.25	0.5

Recommended Soldering Conditions

Recommendations and precautions are described below

● Recommended soldering conditions for reflow

- Reflow soldering shall be performed a maximum of two times.
- Please contact us for additional information when used in conditions other than those specified.
- Please measure the temperature of the terminals and study every kind of solder and printed circuit board for solderability before actual use.

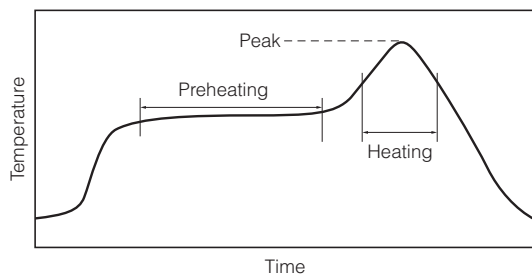

● Flow soldering

- We do not recommend flow soldering, because flow soldering may cause bridges between the electrodes.

For soldering (Example : Sn-37Pb)

	Temperature	Time
Preheating	140 °C to 160 °C	60 s to 120 s
Main heating	Above 200 °C	30 s to 40 s
Peak	235 ± 10 °C	max. 10 s

For lead-free soldering (Example : Sn/3Ag/0.5Cu)

	Temperature	Time
Preheating	150 °C to 170 °C	60 s to 120 s
Main heating	Above 230 °C	30 s to 40 s
Peak	max. 260 °C	max. 10 s

<Repair with hand soldering>

- Preheat with a blast of hot air or similar method. Use a soldering iron with a tip temperature of 350 °C or less. Solder each electrode for 3 seconds or less.
- Never touch this product with the tip of a soldering iron.

Common mode Noise Filters with ESD Suppressor



Type: **EXC14CS**

Features

- Provides EMI Filtering and ESD Protection (L 0.85 mm×W 0.65 mm×H 0.45 mm)
- ESD and noise suppression of high-speed differential transmission lines with little influence of waveform rounding on signal transmission
- High Common mode attenuation in the range between 700 MHz and 1 GHz (RF band)
- Strong multilayer/sintered structure, excellent reflow resistance and high mounting reliability
- Lead, halogen and antimony-free
- RoHS compliant

Recommended Applications

- Smartphones, Tablet PCs and DSC
- ESD and noise suppression of high-speed differential data lines such as MIPI and USB

Explanation of Part Numbers

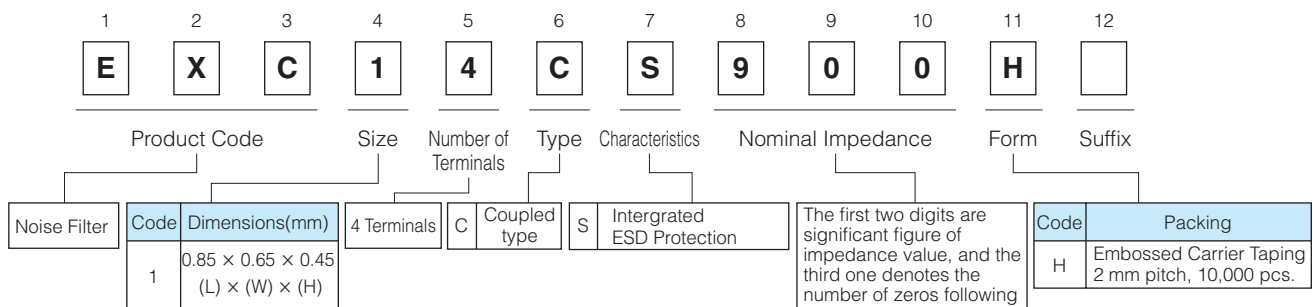

Construction

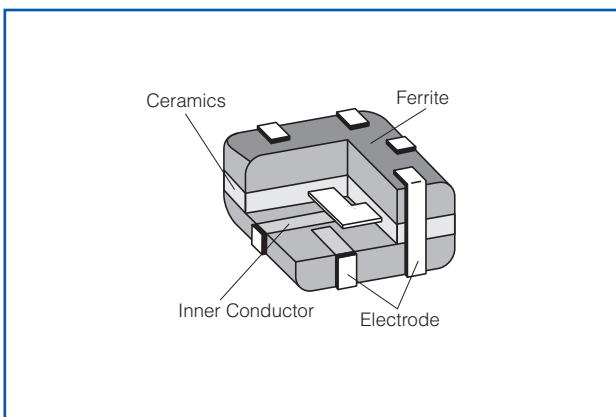

Dimensions in mm (not to scale)

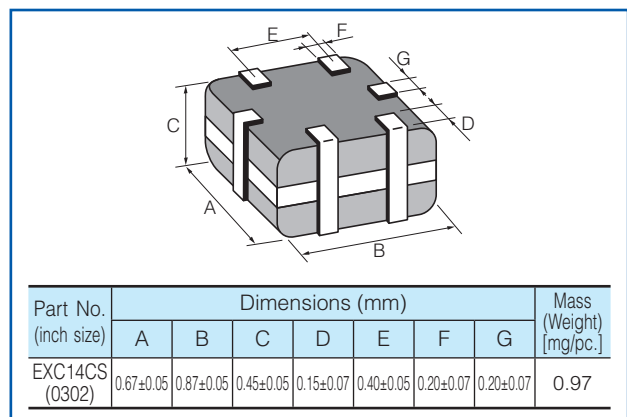

Circuit Configuration(No Polarity)

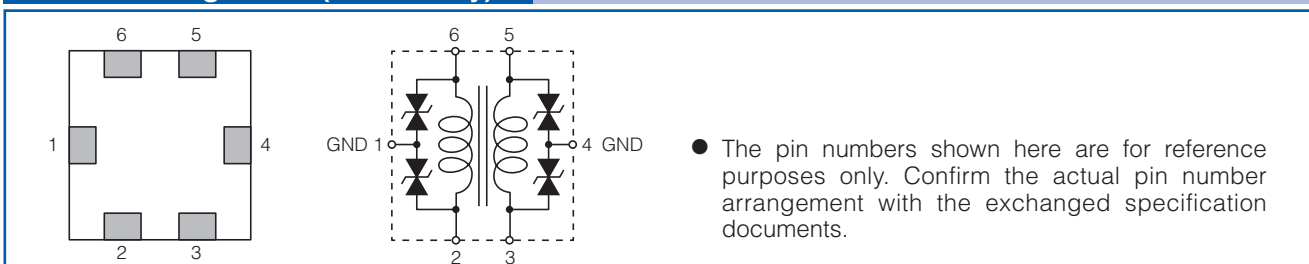

Ratings

Part Number	Impedance (Ω) at 100 MHz		Rated Voltage (V DC)	Rated Current (mA DC)	DC Resistance (Ω)
	Common Mode	Differential Mode			
EXC14CS350H	35 $\Omega \pm 30\%$	15 Ω max.	5	100	2.0 $\pm 30\%$
EXC14CS900H	90 $\Omega \pm 20\%$	20 Ω max.	5	100	3.3 $\pm 30\%$

- Category Temperature Range $-40\text{ }^\circ\text{C}$ to $+85\text{ }^\circ\text{C}$

Impedance Characteristics (Typical)

● EXC14CS350H

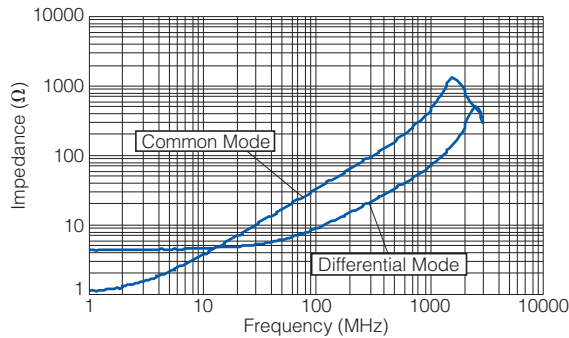

● EXC14CS900H

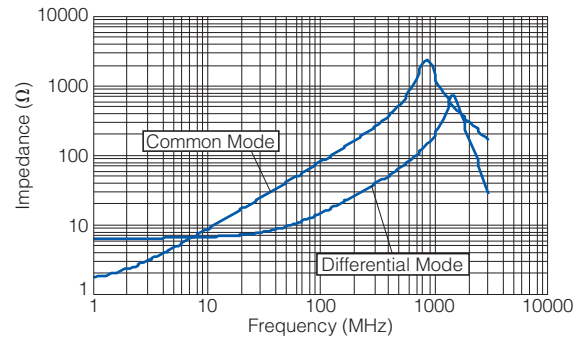

● Measurement Circuit

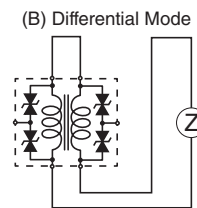
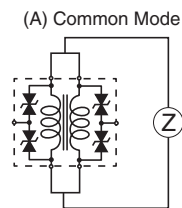

ESD Suppression Characteristics (Typical: IEC61000-4-2, 8 kV contact discharge)

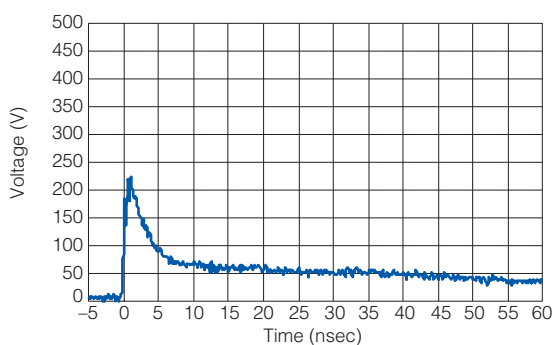

Recommended Land Pattern Design in mm (not to scale)

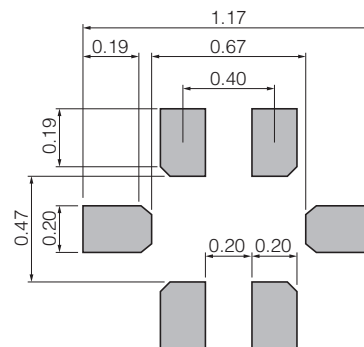

■ As for Packaging Methods, Soldering Conditions and Safety Precautions,

Please see Data Files

Common mode Noise Filters with ESD Suppressor

Type: **EXC24CS**



Features

- Provides EMI Filtering and ESD Protection (L 1.25 mm×W 1.00 mm×H 0.50 mm)
- ESD and noise suppression of high-speed differential transmission lines with little influence of waveform rounding on signal transmission
- High Common mode attenuation in the range between 700 MHz and 1 GHz (RF band)
- Strong multilayer/sintered structure, excellent reflow resistance and high mounting reliability
- Lead, halogen and antimony-free
- RoHS compliant

Recommended Applications

- Smartphones, Tablet PCs and DSC
- ESD and noise suppression of high-speed differential data lines such as MIPI and USB

Explanation of Part Numbers

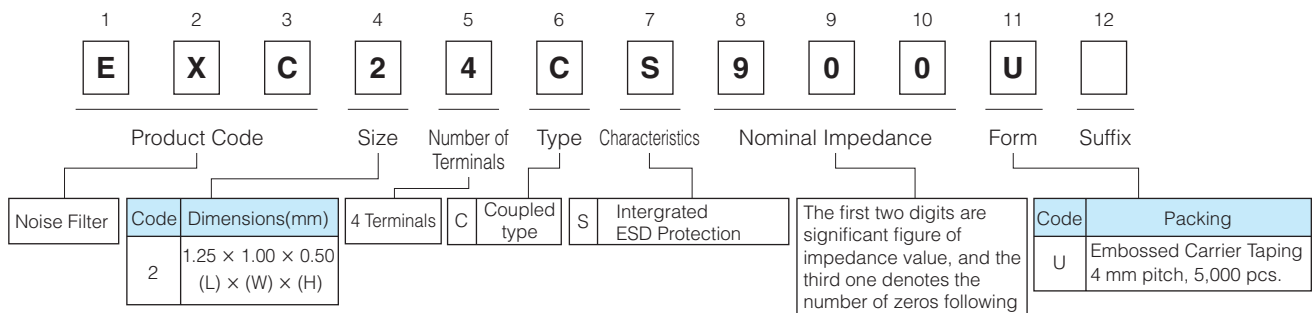

Construction

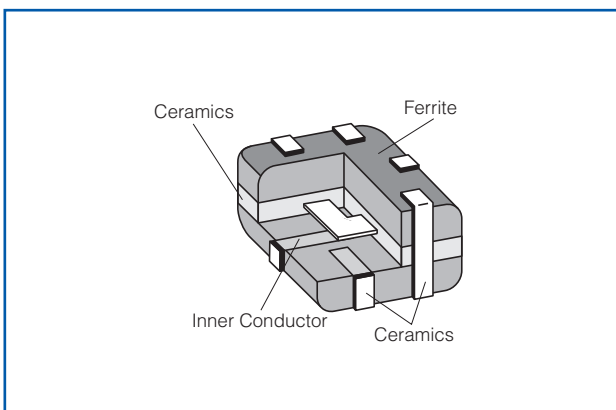

Dimensions in mm (not to scale)

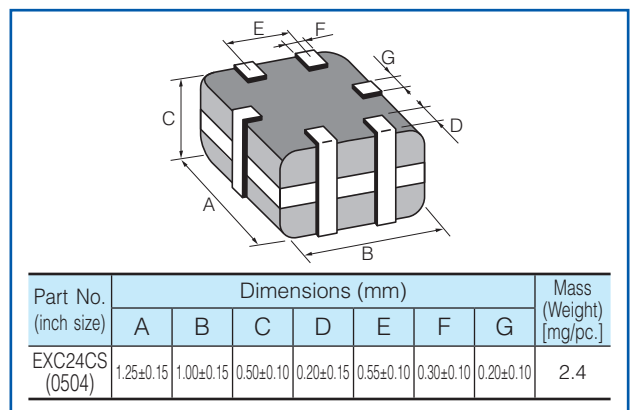

Circuit Configuration (No Polarity)

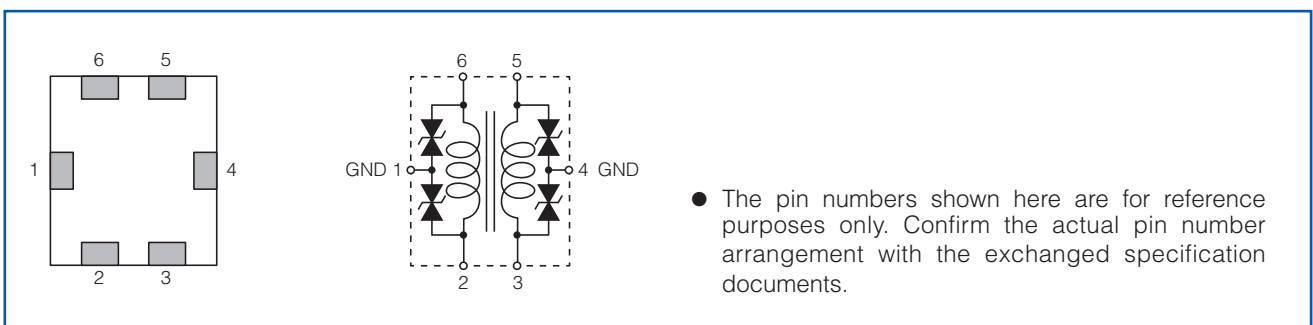

Ratings

Part Number	Impedance (Ω) at 100 MHz		Rated Voltage (V DC)	Rated Current (mA DC)	DC Resistance (Ω)max.
	Common Mode	Differential Mode			
EXC24CS350U	35 Ω ±30 %	15 Ω max.	5	100	2.0
EXC24CS900U	90 Ω ±20 %	20 Ω max.	5	100	3.0

- Category Temperature Range -40 °C to +85 °C

Impedance Characteristics (Typical)

● EXC24CS350U

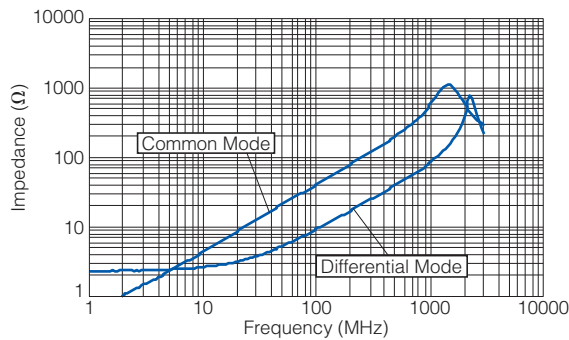

● EXC24CS900U

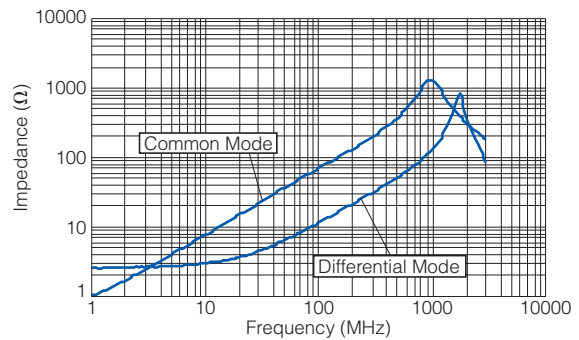

● Measurement Circuit

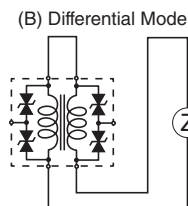
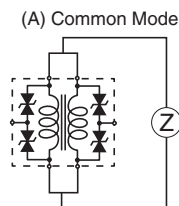

ESD Suppression Characteristics(Typical : IEC61000-4-2, 8 kV contact discharge)

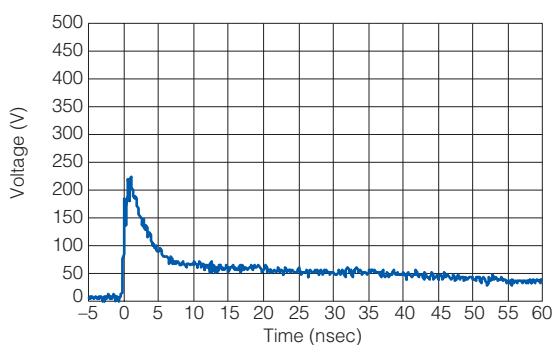

Recommended Land Pattern Design in mm (not to scale)

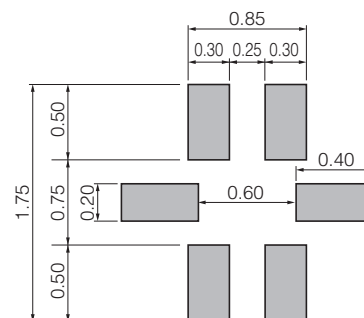

■ As for Packaging Methods, Soldering Conditions and Safety Precautions,

Please see Data Files

Common mode Noise Filter Array with ESD Suppressor

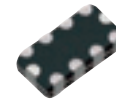

Type: **EXC18CS**

Features

- Provides EMI Filtering and ESD Protection (L 1.6 mm×W 0.8 mm×H 0.4 mm)
- ESD and noise suppression of high-speed differential transmission lines with little influence of waveform rounding on signal transmission
- High Common mode attenuation in the range between 700 MHz and 1 GHz (RF band)
- Strong multilayer/sintered structure, excellent reflow resistance and high mounting reliability
- Lead, halogen and antimony-free
- RoHS compliant

Recommended Applications

- Smartphones, Tablet PCs and DSC
- ESD and noise suppression of high-speed differential data lines such as MIPI and USB

Explanation of Part Numbers

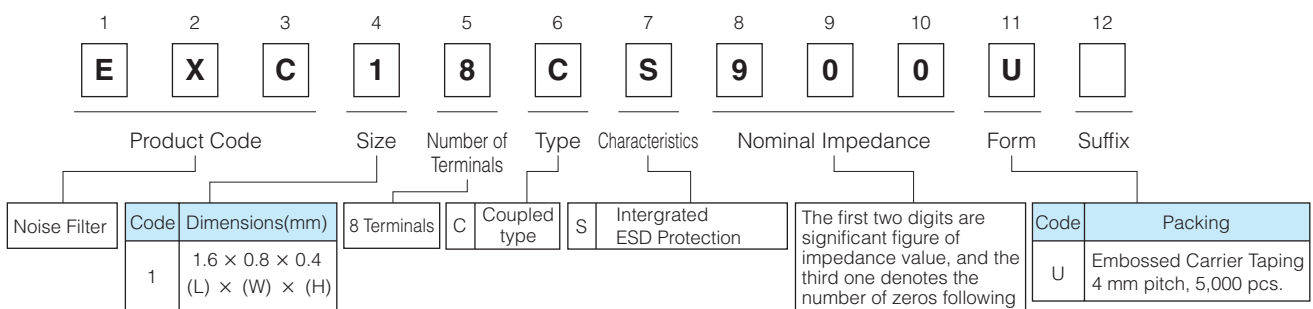

Construction

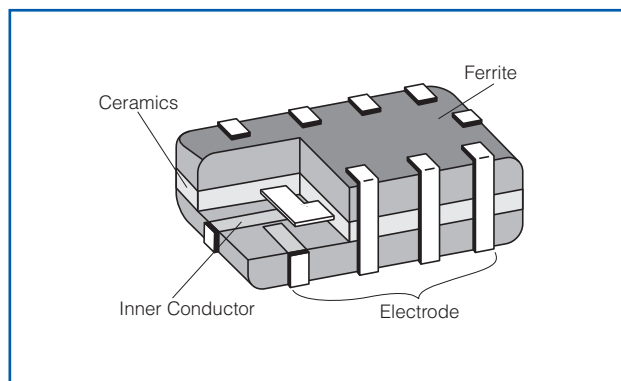

Dimensions in mm (not to scale)

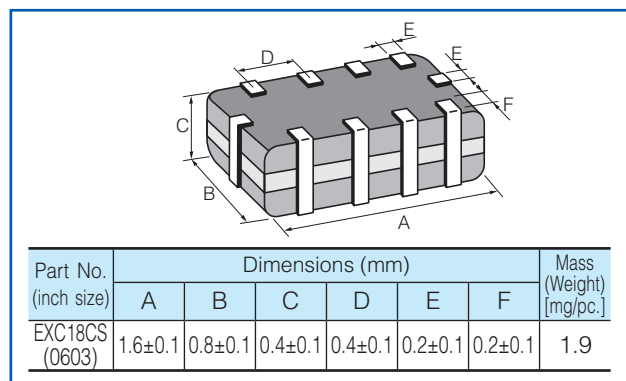

Circuit Configuration (No Polarity)

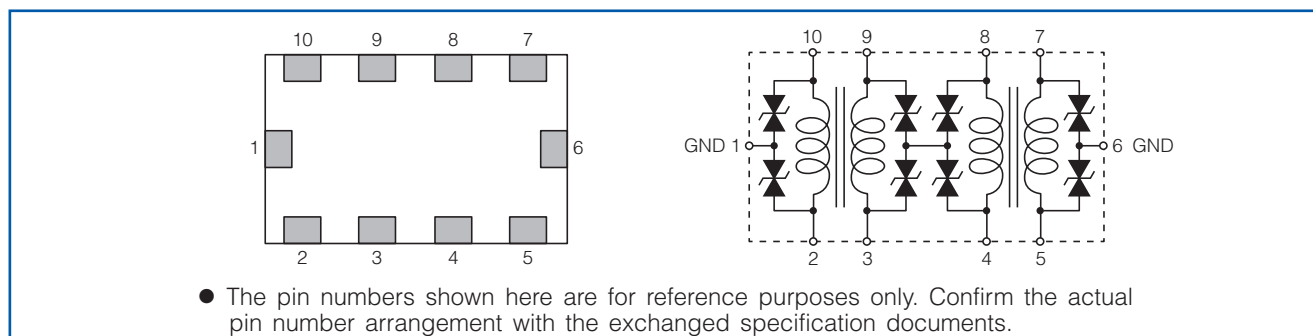

Ratings

Part Number	Impedance (Ω) at 100 MHz		Rated Voltage (V DC)	Rated Current (mA DC)	DC Resistance (Ω)
	Common Mode	Differential Mode			
EXC18CS350U	35 Ω \pm 30 %	15 Ω max.	5	100	1.8 \pm 30 %
EXC18CS900U	90 Ω \pm 20 %	20 Ω max.	5	100	3.0 \pm 30 %

- Category Temperature Range -40 °C to $+85$ °C

Impedance Characteristics (Typical)

● EXC18CS350U

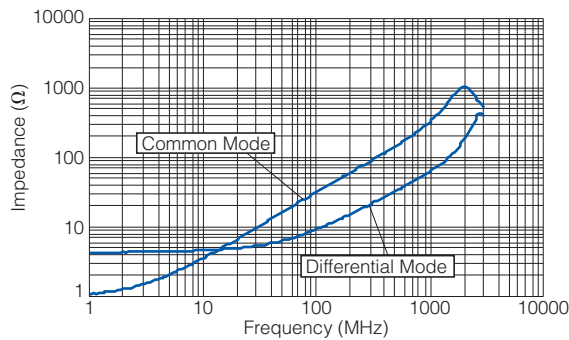

● EXC18CS900U

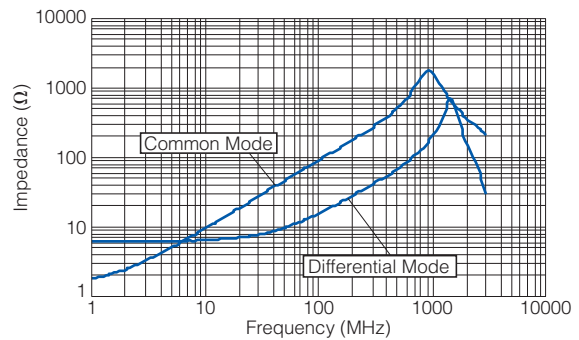

● Measurement Circuit

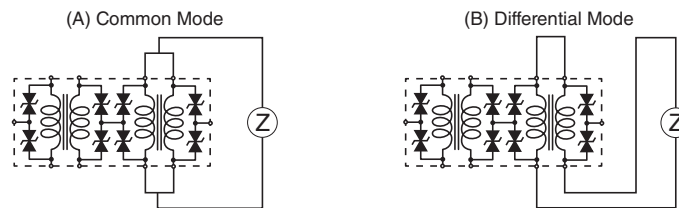

ESD Suppression Characteristics (Typical: IEC61000-4-2, 8 kV contact discharge)

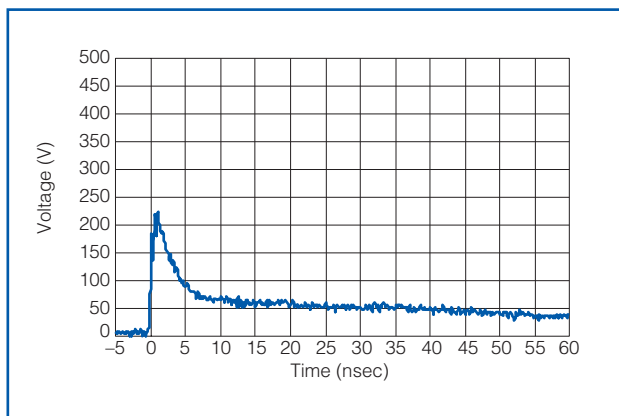

Recommended Land Pattern Design in mm (not to scale)

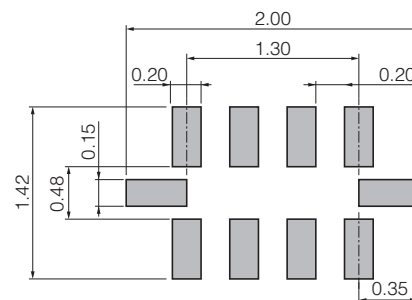

■ As for Packaging Methods, Soldering Conditions and Safety Precautions,

Please see Data Files

Packaging Methods (Taping)

- Standard Quantity

Part Number	Size (inch)	Type	Kind of Taping	Pitch (P ₁)	Quantity
EXC14CS	0302	Single	Embossed Carrier Taping	2 mm	10,000 pcs./reel
EXC24CS	0504			4 mm	5,000 pcs./reel
EXC18CS	0603	Array			

- Embossed Carrier Taping
EXC14CS

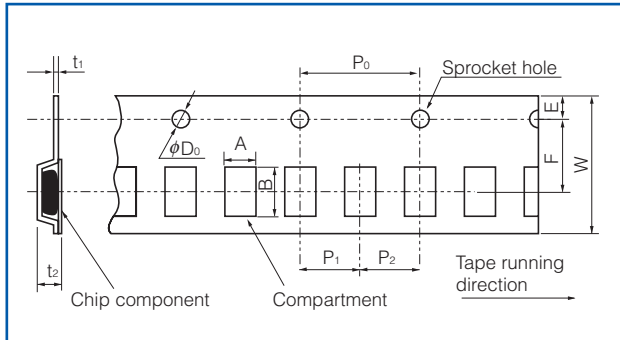

- Embossed Carrier Taping
EXC18CS, EXC24CS

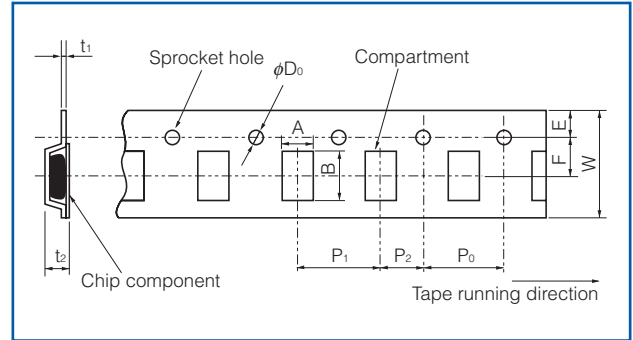

- Taping Reel

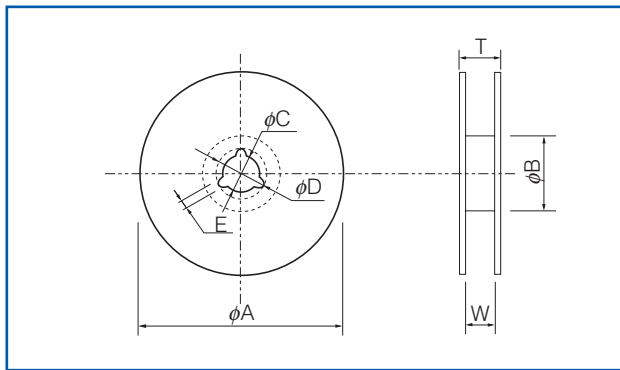

- Embossed Carrier Taping

(mm)

Part Number	A	B	W	F	E	P ₁	P ₂	P ₀	ϕD_0	t ₁	t ₂
EXC14CS	0.75±0.10	0.95±0.10	8.0±0.2	3.50±0.05	1.75±0.10	2.0±0.1	2.0±0.1	4.0±0.1	1.5 ^{+0.1} ₀	0.25±0.05	0.85±0.15
EXC18CS	1.00±0.10	1.80±0.10	8.0±0.2	3.5±0.1	1.75±0.10	4.0±0.1	2.0±0.1	4.0±0.1	1.5 ^{+0.1} ₀	0.25±0.05	0.50±0.05
EXC24CS	1.20±0.15	1.45±0.15									0.90±0.15

- Taping Reel

Standard Reel Dimensions

(mm)

Part Number	ϕA	ϕB	ϕC	ϕD	E	W	T
EXC14CS EXC18CS EXC24CS	180.0±3.0	60.0±1.0	13.0±0.5	21.0±0.8	2.0±0.5	9.0±0.3	11.4±1.5

Recommended Soldering Conditions

Recommendations and precautions are described below

- Recommended soldering conditions for reflow
 - Reflow soldering shall be performed a maximum of two times.
 - Please contact us for additional information when used in conditions other than those specified.
 - Please measure the temperature of the terminals and study every kind of solder and printed circuit board for solderability before actual use.

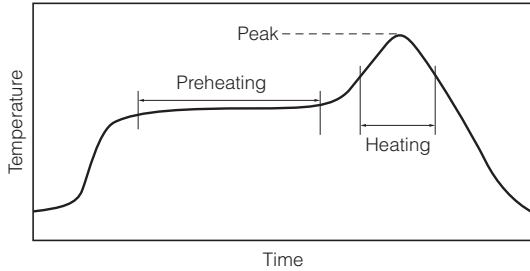

- Flow soldering
 - We do not recommend flow soldering, because flow soldering may cause bridges between the electrodes.

For soldering (Example : Sn-37Pb)

	Temperature	Time
Preheating	140 °C to 160 °C	60 s to 120 s
Main heating	Above 200 °C	30 s to 40 s
Peak	235 ± 10 °C	max. 10 s

For lead-free soldering (Example : Sn/3Ag/0.5Cu)

	Temperature	Time
Preheating	150 °C to 170 °C	60 s to 120 s
Main heating	Above 230 °C	30 s to 40 s
Peak	max. 260 °C	max. 10 s

<Repair with hand soldering>

- Preheat with a blast of hot air or similar method. Use a soldering iron with a tip temperature of 350 °C or less. Solder each electrode for 3 seconds or less.
- Never touch this product with the tip of a soldering iron.

2 mode Noise Filters

Type: **EXC14CP**



Features

- Small size and low-profile : 0302 inch size (L 0.85 mm×W 0.65 mm×H 0.45 mm)
- Burst/radiation noise filtering for audio circuits
- The optimally magnetic-coupled ferrite beads allow for the filtering of both common and normal mode noises
- The strong multi-layer structure provides high resistance to reflow soldering heat and a high mounting reliability
- Lead, halogen, and antimony free
- RoHS compliant

Recommended Applications

- Smart phones, Tablet PCs, DSC and Portable Music Player
- Noise suppression of burst noise of Receiver/Microphone and D-class power amplifier

Explanation of Part Numbers

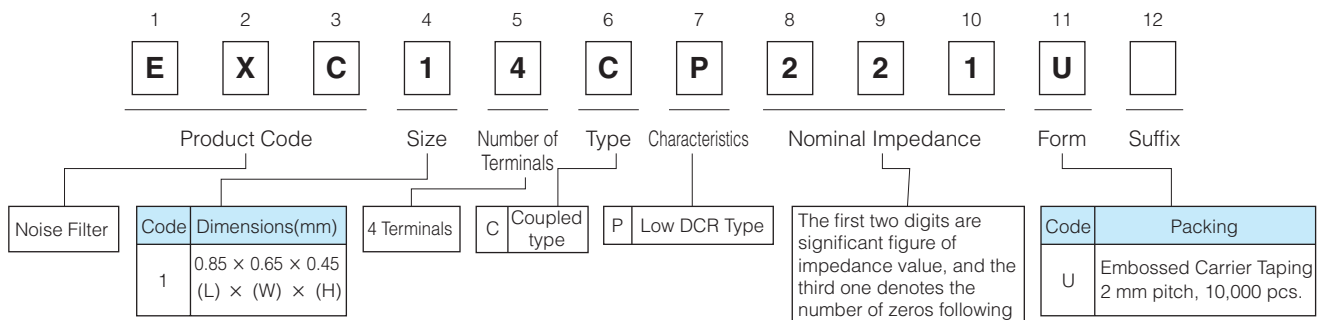

Construction

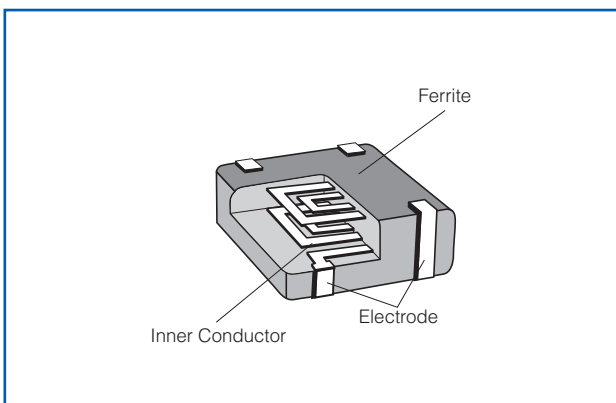

Dimensions in mm (not to scale)

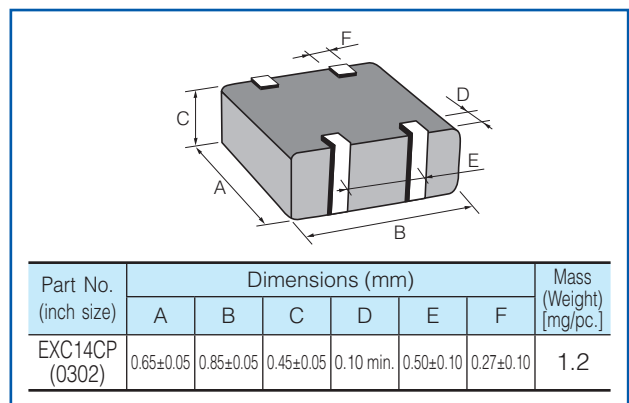

Circuit Configuration (No Polarity)

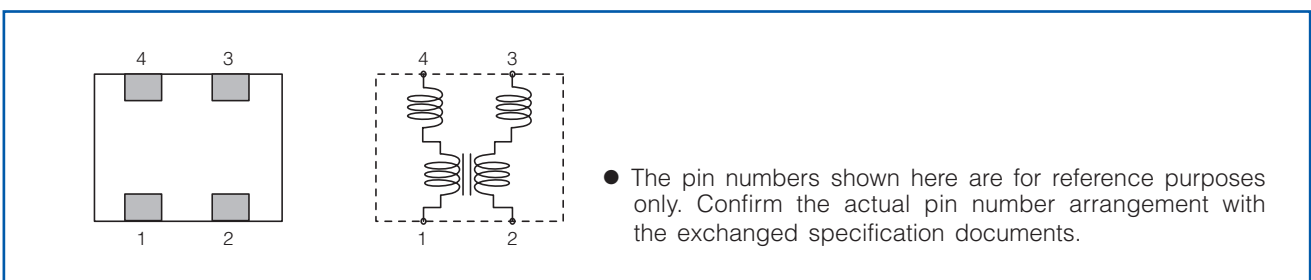

Ratings

Part Number	Impedance(Ω) at 100 MHz		Rated Voltage (V DC)	Rated Current (mA DC)	DC Resistance (Ω) max.
	Open mode	Common mode			
EXC14CP121U	120 $\Omega \pm 30\%$	75 $\Omega \pm 25\%$	5	300	0.5
EXC14CP221U	220 $\Omega \pm 30\%$	140 $\Omega \pm 25\%$		200	0.7

- Category Temperature Range $-40\text{ }^{\circ}\text{C}$ to $+85\text{ }^{\circ}\text{C}$

Impedance Characteristics (Typical)

● EXC14CP121U

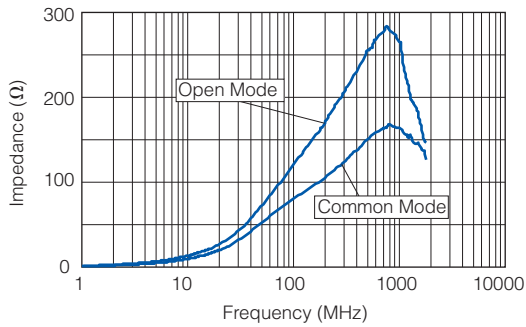

● EXC14CP221U

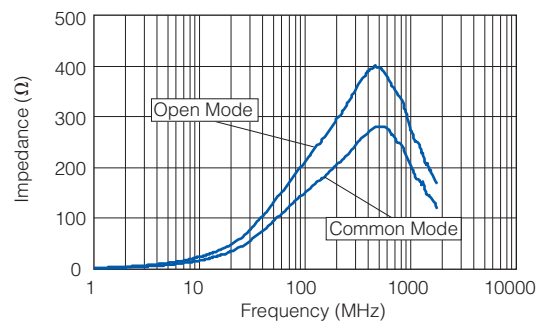

● Measurement Circuit

(A) Open Mode

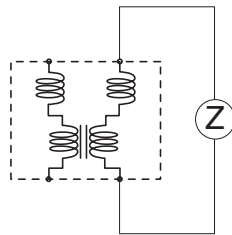

(B) Common Mode

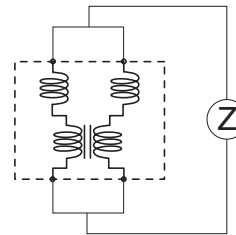

- As for Packaging Methods, Land Pattern, Soldering Conditions and Safety Precautions, Please see Data Files

2 mode Noise Filters

Type: **EXC24CB/CP**
EXC24CN



Features

- Burst/radiation noise filtering for audio circuits
- The optimally magnetic-coupled ferrite beads allow for the filtering of both common and normal mode noises
- The strong multi-layer structure provides high resistance to reflow soldering heat and a high mounting reliability
- Magnetic shield type
- High Impedance : 220 to 1 k Ω (EXC24CB type)
- Low Resistance Value : 0.4 Ω max. (EXC24CP type)
- High Impedance : 600 Ω , Low Resistance Value : 0.9 Ω max. (EXC24CN type)
- RoHS compliant

Recommended Applications

- Smart phones, Tablet PCs, DSC and Portable Music Player
- Noise suppression of burst noise of Receiver/Microphone and D-class power amplifier

Explanation of Part Numbers

- EXC24CB/CP Type

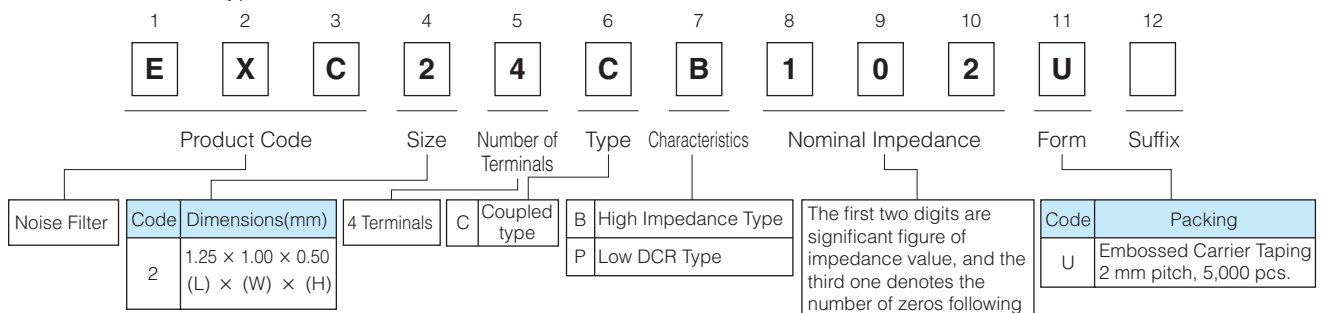

- EXC24CN Type

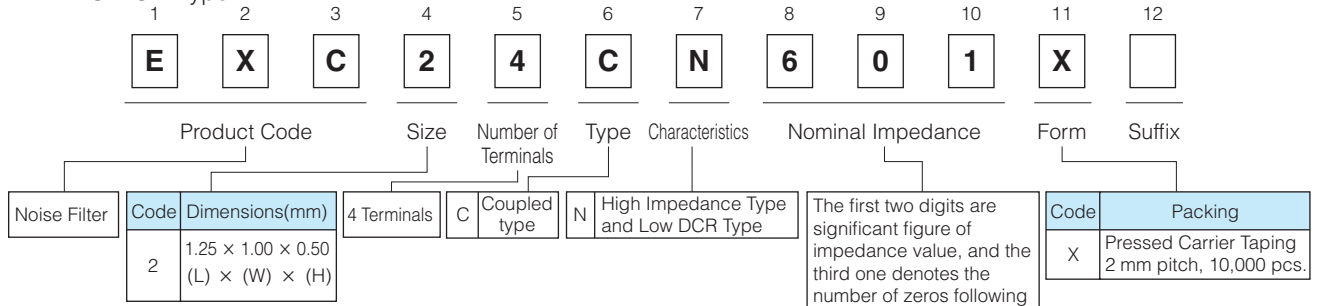

Construction

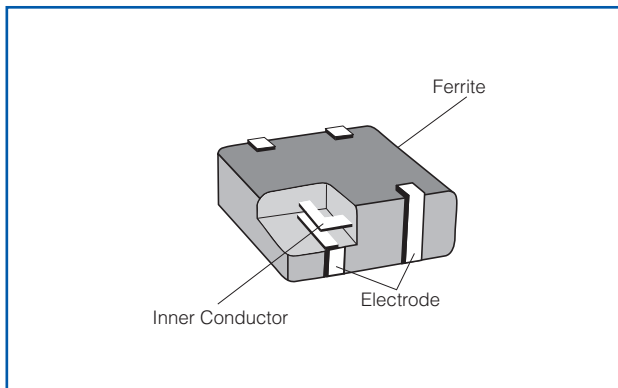

Dimensions in mm (not to scale)

Part No. (inch size)	Dimensions (mm)						Mass (Weight) [mg/pc.]
	A	B	C	D	E	F	
EXC24C (0504)	1.00±0.15	1.25±0.15	0.50±0.10	0.20±0.15	0.65±0.10	0.35±0.10	3

Circuit Configuration (No Polarity)

- The pin numbers shown here are for reference purposes only. Confirm the actual pin number arrangement with the exchanged specification documents.

Ratings

Part Number	Impedance (Open mode)		Rated Voltage (V DC)	Rated Current (mA DC)	DC Resistance (Ω) max.
	(Ω) at 100MHz	Tolerance(%)			
EXC24CP121U	120	±25	5	500	0.3
EXC24CP221U	220			350	0.4
EXC24CB221U	220			100	0.7
EXC24CB102U	1000			50	1.5

Part Number	Impedance (Common mode)		Rated Voltage (V DC)	Rated Current (mA DC)	DC Resistance (Ω) max.
	(Ω) at 100MHz	Tolerance(%)			
EXC24CN601X	600	±25	5	200	0.9

● Category Temperature Range -40 °C to +85 °C

Impedance Characteristics (Typical)

● EXC24CP121U

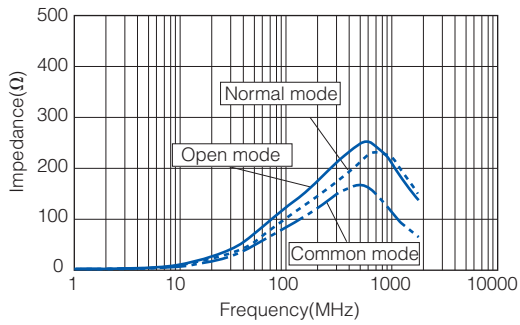

● EXC24CP221U

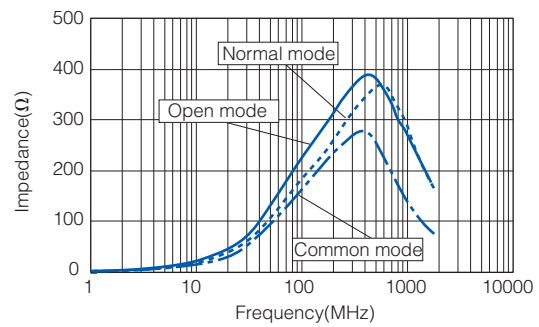

● EXC24CB221U

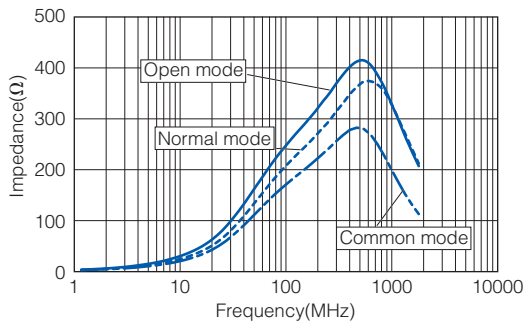

● EXC24CB102U

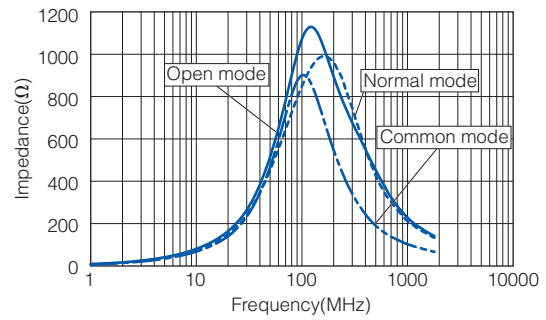

● Measurement Circuit

(A) Open Mode

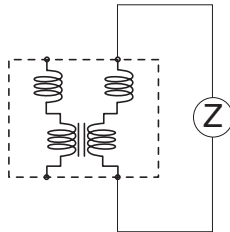

(B) Common Mode

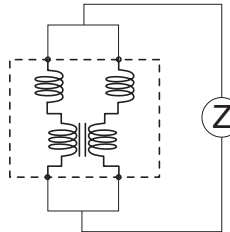

(C) Normal Mode

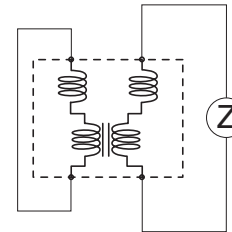

Attenuation Characteristics (Typical)

● EXC24CN601X

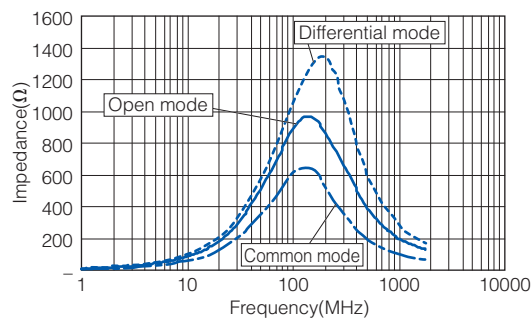

● Measurement Circuit

(A) Open Mode

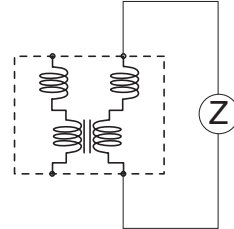

(B) Common Mode

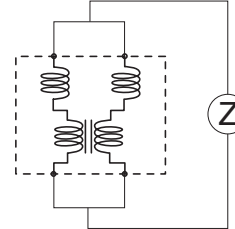

(C) Differential Mode

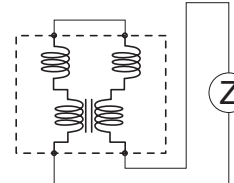

■ As for Packaging Methods, Land Pattern, Soldering Conditions and Safety Precautions, Please see Data Files

Packaging Methods (Taping)

- Standard Quantity

Part Number	Size (inch)	Kind of Taping	Pitch (P ₁)	Quantity
EXC14CP□□□U	0302	Embossed Carrier Taping	2 mm	10,000 pcs./reel
EXC24CP/CB□□□U	0504		4 mm	5,000 pcs./reel
EXC24CN□□□X	0504	Pressed Carrier Taping	2 mm	10,000 pcs./reel

- Embossed Carrier Taping

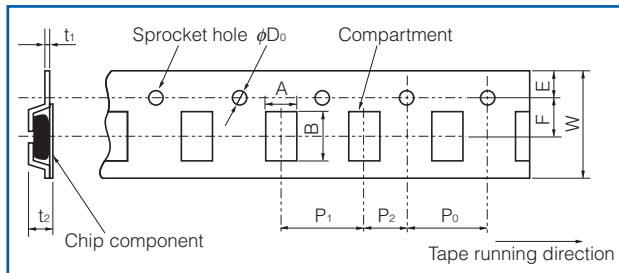

- Pressed Carrier Taping

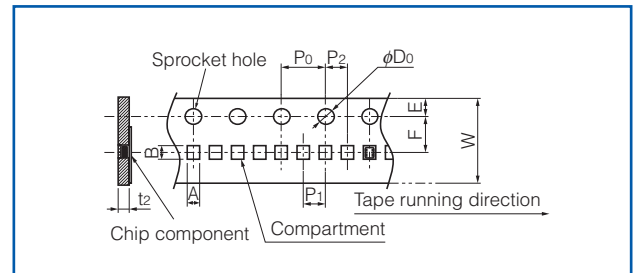

- Taping Reel

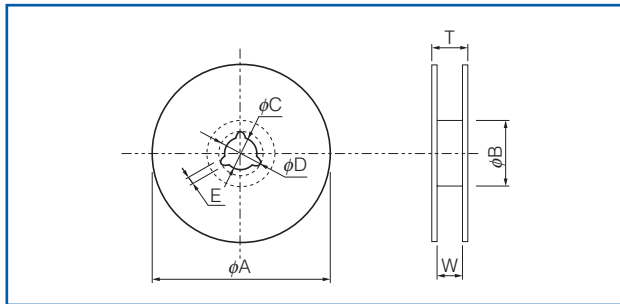

- Embossed Carrier Dimensions

(mm)

Part Number	A	B	W	F	E	P ₁	P ₂	P ₀	φD ₀	t ₁	t ₂
EXC14CP	0.75±0.10	0.95±0.10	8.0±0.2	3.50±0.05	1.75±0.10	2.0±0.1	2.0±0.1	4.0±0.1	1.5 ^{+0.1} ₀	0.25±0.05	0.85±0.15
EXC24CP/CB	1.20±0.15	1.45±0.15	8.0±0.2	3.5±0.1	1.75±0.10	4.0±0.1	2.0±0.1	4.0±0.1	1.5 ^{+0.1} ₀	0.25±0.05	0.90±0.15

- Pressed Carrier Dimensions

(mm)

Part Number	A	B	W	F	E	P ₁	P ₂	P ₀	φD ₀	t ₂
EXC24CN	1.14±0.10	1.38±0.15	8.0±0.2	3.5±0.1	1.75±0.10	2.0±0.1	2.0±0.1	4.0±0.1	1.5 ^{+0.1} ₀	0.68±0.10

- Standard Reel Dimensions

(mm)

Part Number	φA	φB	φC	φD	E	W	T
EXC14C/EXC24C	180.0±3.0	60.0±1.0	13.0±0.5	21.0±0.8	2.0±0.5	9.0±0.3	11.4±1.5

Recommended Land Pattern Design

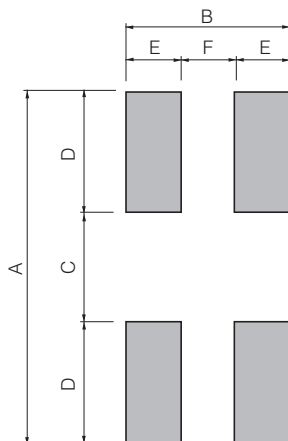

Part Number	Dimension (mm)					
	A	B	C	D	E	F
EXC14CP	0.80 to 1.00	0.80	0.30	0.25 to 0.35	0.30	0.20
EXC24CP EXC24CB EXC24CN	1.50 to 1.90	1.10	0.50	0.50 to 0.70	0.40	0.30

Recommended Soldering Conditions

Recommendations and precautions are described below.

- Recommended soldering conditions for reflow
 - Reflow soldering shall be performed a maximum of two times.
 - Please contact us for additional information when used in conditions other than those specified.
 - Please measure the temperature of the terminals and study every kind of solder and printed circuit board for solderability before actual use.

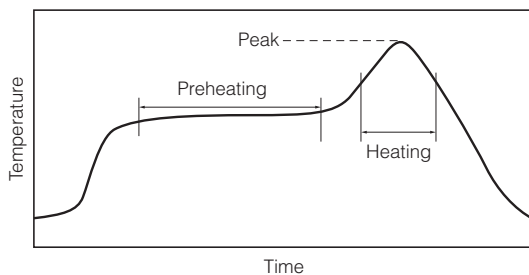

- Flow soldering
 - We do not recommend flow soldering, because flow soldering may cause bridges between the electrodes.

For soldering (Example : Sn-37Pb)

	Temperature	Time
Preheating	140 °C to 160 °C	60 s to 120 s
Main heating	Above 200 °C	30 s to 40 s
Peak	235 ± 10 °C	max. 10 s

For lead-free soldering (Example : Sn/3Ag/0.5Cu)

	Temperature	Time
Preheating	150 °C to 170 °C	60 s to 120 s
Main heating	Above 230 °C	30 s to 40 s
Peak	max. 260 °C	max. 10 s

<Repair with hand soldering>

- Preheat with a blast of hot air or similar method. Use a soldering iron with a tip temperature of 350 °C or less. Solder each electrode for 3 seconds or less.
- Never touch this product with the tip of a soldering iron.

Performance

Test Item	Performance Requirements	Test Conditions
Resistance	Within Specified Tolerance	25 °C
Overload	–	Rated Voltage
Resistance to Soldering Heat	±30 % (Impedance Change)	260 °C, 10 s
Rapid Change of Temperature	±30 % (Impedance Change)	–40 °C (30 min.) / +85 °C (30 min.), 200 cycles
High Temperature Exposure	±30 % (Impedance Change)	85 °C, 500 h
Damp Heat, Steady State	±30 % (Impedance Change)	60 °C, 95 %RH, 500 h
Load Life in Humidity	±30 % (Impedance Change)	60 °C, 95 %RH, Rated Current, 500 h

Safety Precautions

(Common mode Noise Filters/Array, Common mode Noise Filters/Array with ESD Suppressor, 2 mode Noise Filters)

The following are precautions for individual products. Please also refer to the common precautions for EMC Components in this catalog.

1. Use rosin-based flux or halogen-free flux.
2. For cleaning, use an alcohol-based cleaning agent. Before using any other type, consult with our sales person in advance.
3. Do not apply shock to Common mode Noise Filters and 2 mode Noise Filters (hereafter called the filters) or pinch them with a hard tool (e.g. pliers and tweezers). Otherwise, their bodies may be chipped, affecting their performance. Excessive mechanical stress may damage the filters. Handle with care.
4. Store the filters in a location with a temperature ranging from $-5\text{ }^{\circ}\text{C}$ to $+40\text{ }^{\circ}\text{C}$ and a relative humidity of 40 % to 60 % , where there are no rapid changes in temperature or humidity.
5. Use the filters within a year from the date of arrival at your company, provided that they remain packed as they were when delivered.

ESD Suppressor

Type: **EZAEG**

EZAEG2A, 3A



Features

- ESD protection of high-speed data lines
- Low capacitance 0.05 pF : 1005(0402) size
0.10 pF : 1608(0603) size
- Good ESD suppression characteristics
- Good ESD withstanding
- RoHS compliant

Recommended Applications

- Smart phones, Mobile phones, RF Modules, NFC and GPS
- ESD suppression of high-speed differential data line such as Antenna circuit, HDMI, SATA, USB, Display Port

Explanation of Part Numbers

1	2	3	4	5	6	7	8	9	10	11	
E	Z	A	E	G	2	A	5	0	A	X	
Product Code ESD Suppressor	Size		Design Specification		Peak Voltage		Special Feature		Packaging Methods		
	Code	Size mm (inch)	Code	Design Specification	Code	Peak Voltage	Code	Special Feature	Code	Packaging	Part No.
	2	1005 (0402)	A	Rated Voltage 30 V	50	500 V	A	Standard	X	Pressed Carrier Taping 2 mm Pitch, 10,000 pcs.	EZAEG2A
	3	1608 (0603)							V	Punched Carrier Taping 4 mm Pitch, 5,000 pcs.	EZAEG3A

Construction

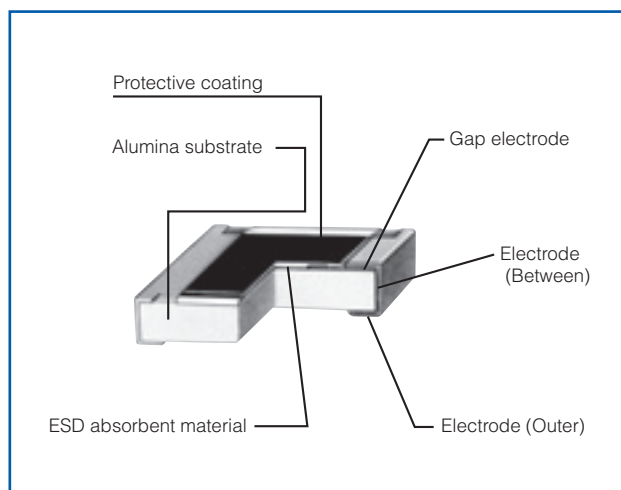

Dimensions in mm (not to scale)

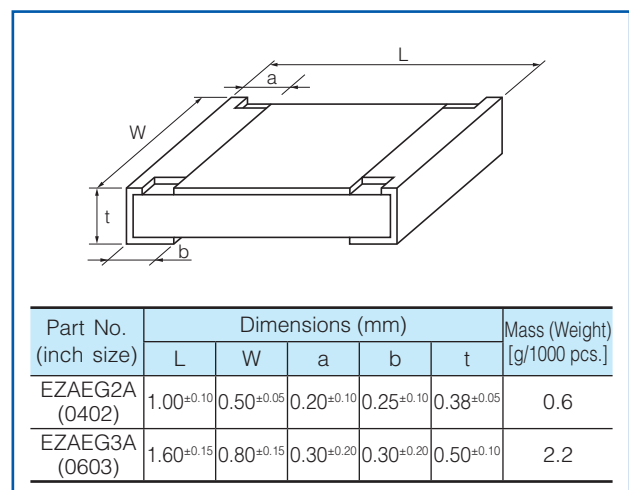

Circuit Configuration

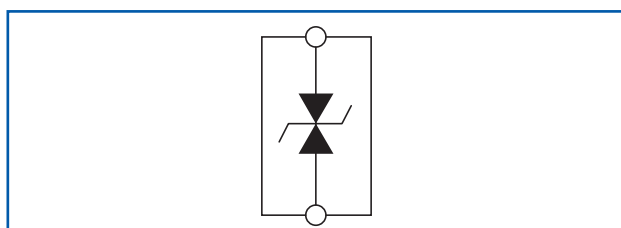

Ratings

Part Number (inch size)	Capacitance ⁽¹⁾	Rated Voltage	Category Temperature Range
EZAEG2A50AX (0402)	0.05 ^{+0.05} _{-0.04} pF	30 V max.	-55 to +125 °C
EZAEG3A50AV (0603)	0.10 ^{+0.10} _{-0.08} pF		

(1) Capacitance = The capacitance value shall be measured under the conditions specified below.
 Frequency : 1 MHz±10 %, Voltage : 1 Vrms±0.2 Vrms, Temperature : 25 °C±2 °C

Performance

Test Item	Performance Requirements	Test Conditions
Peak Voltage	500 V max.	IEC61000-4-2, contact discharge 8 kV, Peak voltage value
Clamping Voltage	100 V max.	IEC61000-4-2, contact discharge 8 kV, voltage at 30 ns after initiation of pulse
Leakage Current	1 µA max.	Current at Rated voltage (DC 30 V)
ESD withstanding	Leakage current 10 µA max.	IEC61000-4-2, contact discharge 8 kV, +/- 10 times
Rapid Change of Temperature	Leakage current 10 µA max.	-55 °C (30 min.) / +125 °C (30 min.), 100 cycles
Load Life in Humidity	Leakage current 10 µA max.	60 °C, 90% to 95%RH, Rated voltage, 1000 h
Endurance at 85 °C	Leakage current 10 µA max.	85 °C, Rated voltage, 1000 h
Resistance to Soldering Heat	Leakage current 10 µA max.	270 °C, 10 s

Frequency Characteristics

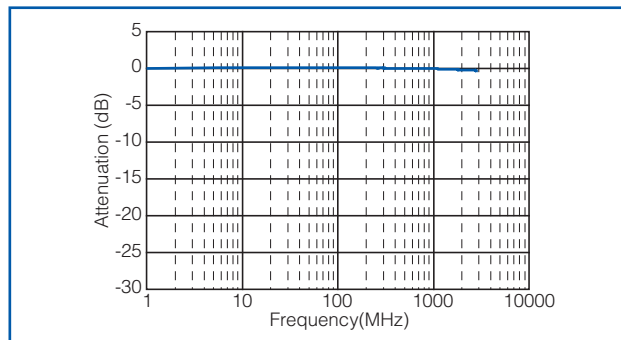

ESD Suppression Voltage Waveform

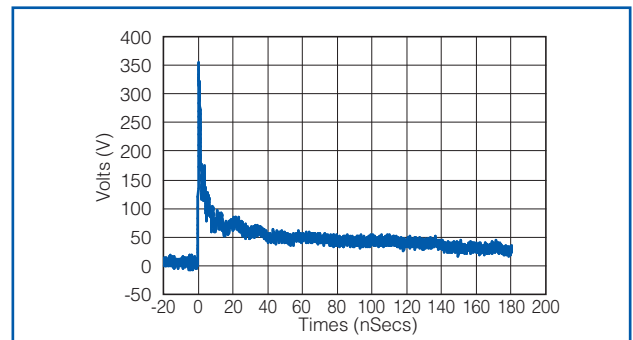

Typical Circuits Requiring Protection

● HDMI circuit

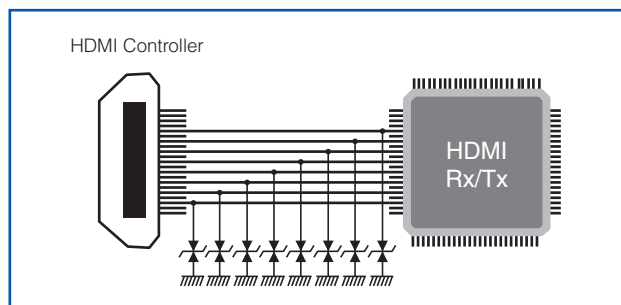

● Antenna circuit

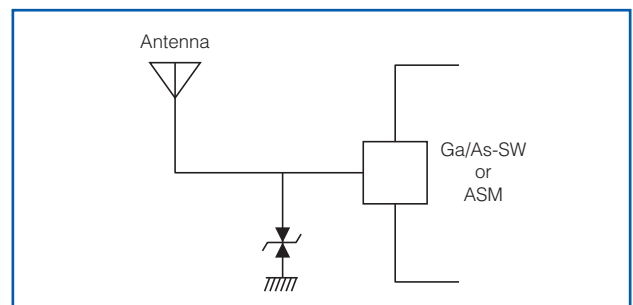

Recommended Land Pattern

Recommended land pattern design for ESD Suppressor is shown below.

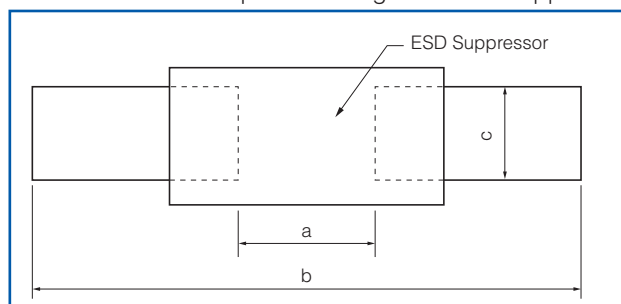

Part Number (inch size)	Dimensions (mm)		
	a	b	c
EZAEG2A (0402)	0.5 to 0.6	1.4 to 1.6	0.4 to 0.6
EZAEG3A (0603)	0.7 to 0.9	2.0 to 2.2	0.8 to 1.0

■ As for Packaging Methods, Soldering Conditions and Safety Precautions,

Please see Data Files

ESD Suppressor

Type: **EZAEG**

EZAEG1N, 2N

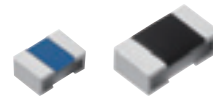

Features

- Good ESD withstanding (IEC61000-4-2 15 kV contact/air Discharge)
- ESD protection of high-speed data lines
- Low capacitance 0.04 pF : 0603(0201) size
0.05 pF : 1005(0402) size
- Good ESD suppression characteristics
- RoHS compliant

Recommended Applications

- Smart phones, Mobile phones, RF Modules, NFC and GPS
- ESD suppression of high-speed differential data line such as Antena circuit, HDMI, SATA, USB, Display Port

Explanation of Part Numbers

1	2	3	4	5	6	7	8	9	10	11	
E	Z	A	E	G	2	N	5	0	A	X	
Product Code ESD Suppressor		Size Code Size mm (inch)		Design Specification Code Design Specification		Peak Voltage Code Peak Voltage		Special Feature Code Special Feature		Packaging Methods Code Packaging Part No.	
		1 0603 (0201)	N ESD withstanding 15 kV Rated Voltage 30 V		50	500 V	A	Standard	C	Pressed Carrier Taping 2 mm Pitch, 15,000 pcs.	EZAEG1N
		2 1005 (0402)							X	Pressed Carrier Taping 2 mm Pitch, 10,000 pcs.	EZAEG2N

Construction

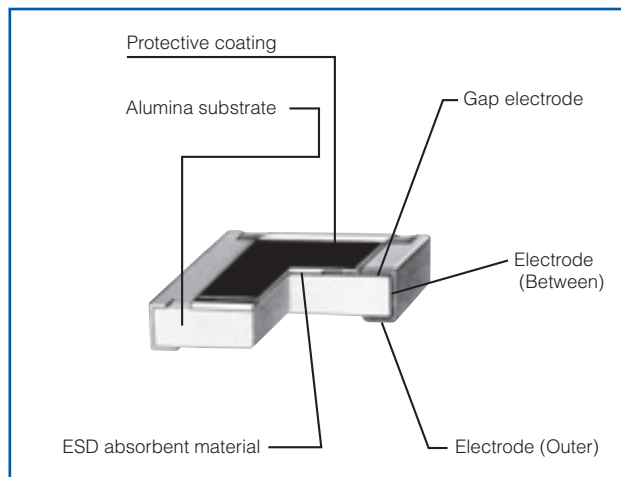

Dimensions in mm (not to scale)

Part No. (inch size)	Dimensions (mm)					Mass (Weight) [g/1000 pcs.]
	L	W	a	b	t	
EZAEG1N (0201)	0.60±0.03	0.30±0.03	0.15±0.10	0.15±0.10	0.23±0.03	0.12
EZAEG2N (0402)	1.00±0.10	0.50±0.05	0.20±0.10	0.27±0.10	0.38±0.05	0.60

Circuit Configuration

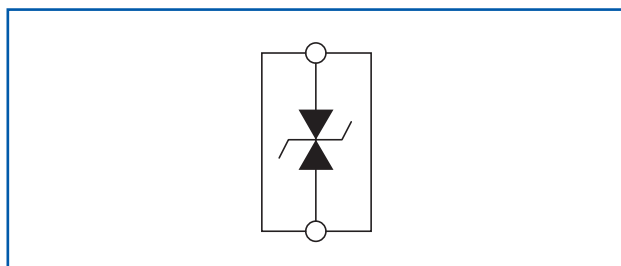

Ratings

Part Number (inch size)	Capacitance ⁽¹⁾	Rated Voltage	Category Temperature Range
EZAEG1N50AC (0201)	0.04 ^{+0.04} _{-0.03} pF	30 V max.	-55 to +125 °C
EZAEG2N50AX (0402)	0.05 ^{+0.05} _{-0.04} pF		

(1) Capacitance = The capacitance value shall be measured under the conditions specified below.
 Frequency : 1 MHz±10 %, Voltage : 1 Vrms±0.2 Vrms, Temperature : 25 °C±2 °C

Performance

Test Item	Performance Requirements	Test Conditions
Peak Voltage	500 V max.	IEC61000-4-2, contact discharge 8 kV, Peak voltage value
Clamping Voltage	100 V max.	IEC61000-4-2, contact discharge 8 kV, voltage at 30 ns after initiation of pulse
Leakage Current	1 µA max.	Current at Rated voltage (DC 30 V)
ESD withstanding	Leakage current 10 µA max.	IEC61000-4-2, contact discharge 15 kV or air discharge 15 kV, +/- 50 times
Rapid Change of Temperature	Leakage current 10 µA max.	-55 °C (30 min.) / +125 °C (30 min.), 100 cycles
Load Life in Humidity	Leakage current 10 µA max.	60 °C, 90% to 95%RH, Rated voltage, 1000 h
Endurance at 85 °C	Leakage current 10 µA max.	85 °C, Rated voltage, 1000 h
Resistance to Soldering Heat	Leakage current 10 µA max.	270 °C, 10 s

Frequency Characteristics

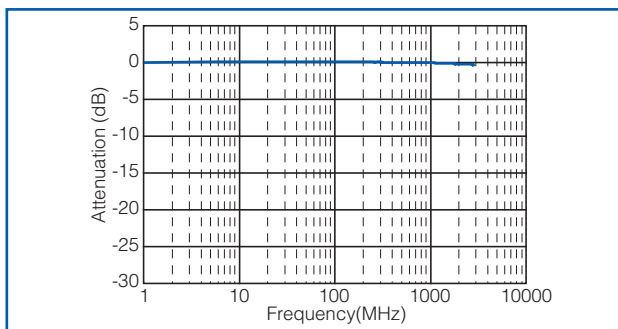

ESD Suppression Voltage Waveform

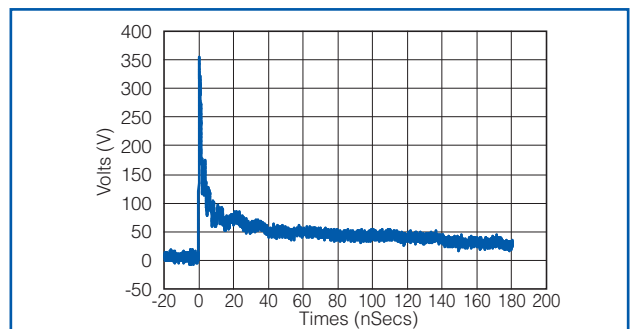

Typical Circuits Requiring Protection

● HDMI circuit

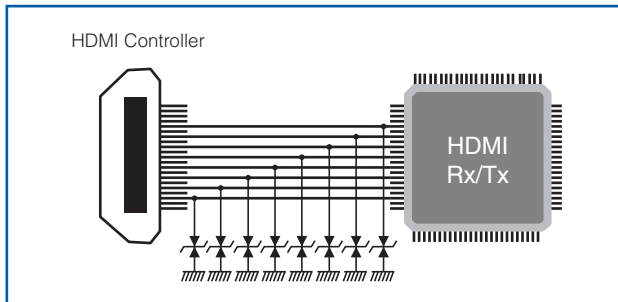

● Antenna circuit

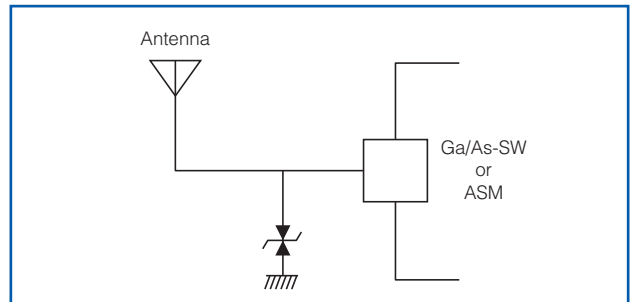

Recommended Land Pattern

Recommended land pattern design for ESD Suppressor is shown below.

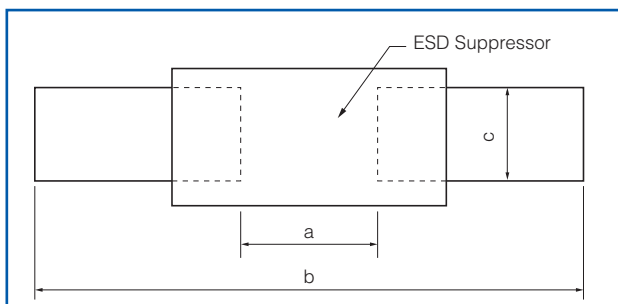

Part Number (inch size)	Dimensions (mm)		
	a	b	c
EZAEG1N (0201)	0.3 to 0.4	0.8 to 0.9	0.25 to 0.35
EZAEG2N (0402)	0.5 to 0.6	1.4 to 1.6	0.40 to 0.60

■ As for Packaging Methods, Soldering Conditions and Safety Precautions,

Please see Data Files

ESD Suppressor Array

Type: **EZAEGCA**



Features

- 4 ESD suppressors in one package
- ESD protection of high-speed data lines
- Low capacitance (0.25 pF)
- Good ESD suppression characteristics
- Good ESD withstanding
- RoHS compliant

Recommended Applications

- AV equipment (LCD-TV, DVD/Blu-ray drives), Information equipment (PCs, HDD,)
- ESD suppression of high-speed differential data line such as USB3.0, HDMI, Display Port

Explanation of Part Numbers

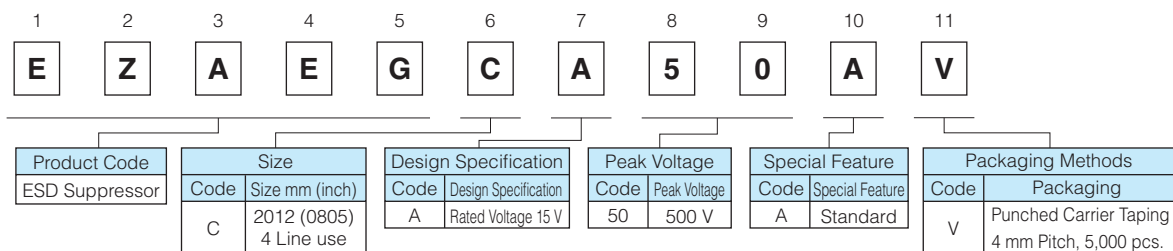

Construction

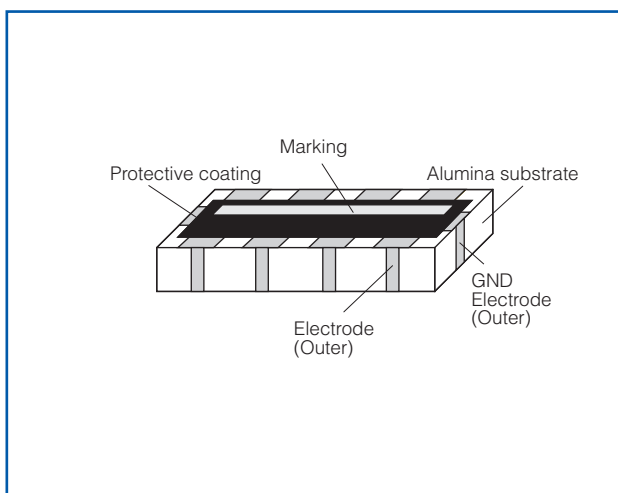

Dimensions in mm (not to scale)

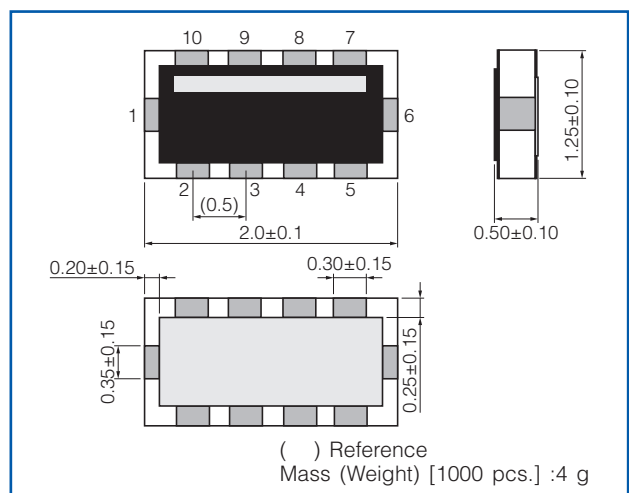

Circuit Configuration

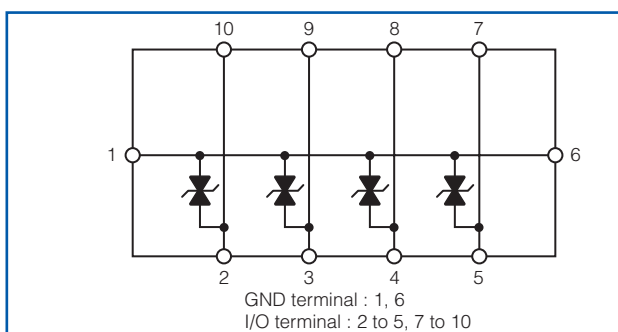

Ratings

Part Number (inch size)	Capacitance ⁽¹⁾	Rated Voltage ⁽²⁾	Rated Current ⁽³⁾	Category Temperature Range
EZAEGCA50AV (0805)	0.25 ^{+0.05} _{-0.10} pF	15 V max.	100 mA max.	-55 to +125 °C

- (1) Capacitance = The capacitance value shall be measured under the conditions specified below.
 Frequency : 1 MHz±10 %, Voltage : 1 Vrms±0.2 Vrms, Temperature : 25 °C±2 °C
- (2) Rated voltage between I/O terminal and GND.
- (3) Rated current between input terminal and output terminal.

Performance

Test Item	Performance Requirements	Test Conditions
Peak Voltage	500 V max.	IEC61000-4-2, contact discharge 8 kV, Peak voltage value
Clamping Voltage	100 V max.	IEC61000-4-2, contact discharge 8 kV, voltage at 30 ns after initiation of pulse
Leakage Current	1 µA max.	Current at Rated voltage (DC 15 V)
ESD withstanding	Leakage current 10 µA max.	IEC61000-4-2, contact discharge 8 kV, +/- 10 times
Rapid Change of Temperature	Leakage current 10 µA max.	-55 °C (30 min.) / +125 °C (30 min.), 100 cycles
Load Life in Humidity	Leakage current 10 µA max.	60 °C, 90% to 95%RH, Rated voltage, 1000 h
Endurance at 85 °C	Leakage current 10 µA max.	85 °C, Rated voltage, 1000 h
Resistance to Soldering Heat	Leakage current 10 µA max.	270 °C, 10 s

Typical Circuits Requiring Protection

● HDMI circuit

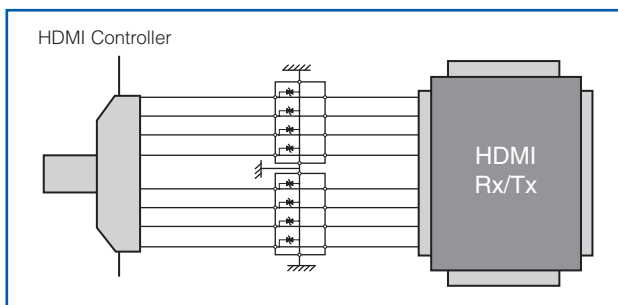

ESD Suppression Voltage Waveform

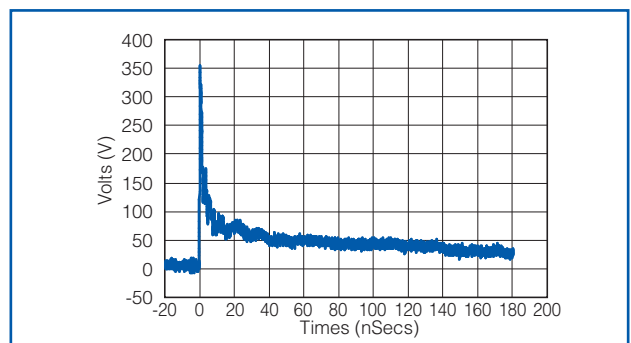

Recommended Land Pattern

Recommended land pattern design for ESD Suppressor Array is shown below.

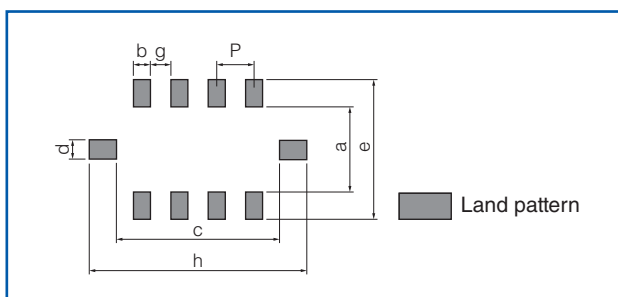

	a	b	c	d
Dimensions (mm)	0.75	0.25	1.70	0.35
	e	h	g	P
Dimensions (mm)	1.85	2.60	0.25	0.50

■ As for Packaging Methods, Soldering Conditions and Safety Precautions,

Please see Data Files

ESD Suppressor, High Withstanding Type

Type: **EZAEG**

EZAEG3W



Features

- Excellent ESD withstanding (Conforms with automotive ESD standards (ISO10605, air discharge 25 kV))
- Low capacitance 0.10 pF : 1608 (0603) size
- High rated voltage (DC 50 V) contributes to reduce the risk of communication error
- AEC-Q200 qualified
- RoHS compliant

Recommended Applications

- High speed data line for automotive (CAN, Ethernet, USB, LVDS)
- Automotive Antenna
- Amusement equipment

Explanation of Part Numbers

1	2	3	4	5	6	7	8	9	10	11	
E	Z	A	E	G	3	W	1	1	A	V	
Product Code		Size		Design Specification		Peak Voltage		Special Feature		Packaging Methods	
ESD Suppressor		Code	Size mm (inch)	Code	Design Specification	Code	Peak Voltage	Code	Special Feature	Code	Part No.
		3	1608 (0603)	W	High with standing type Rated voltage 50 V	11	1000 V	A	Standard	V	Punched Carrier Taping 4 mm Pitch, 4,000 pcs.
EZAEG3W11AV											

Construction

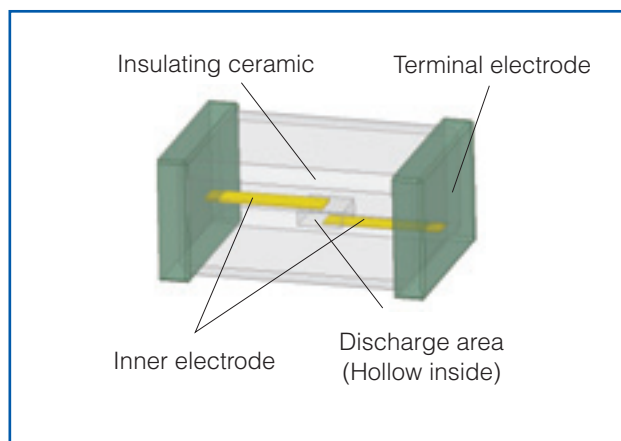

Dimensions in mm (not to scale)

Part No. (inch size)	Dimensions (mm)				Mass (Weight) [g/1000 pcs.]
	L	W	T	a	
EZAEG3W (0603)	1.60±0.15	0.80±0.15	0.80±0.15	0.30±0.20	3.8

Circuit Configuration

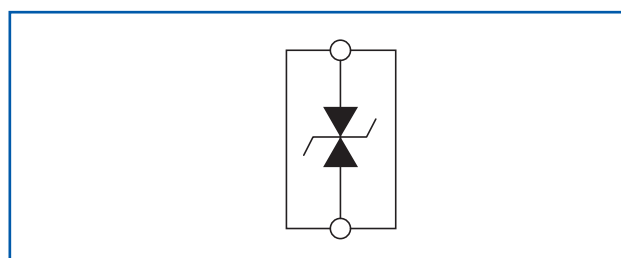

Ratings

Part Number (inch size)	Capacitance ⁽¹⁾	Rated Voltage	Category Temperature Range
EZAEG3W11AV (0603)	0.10 ^{+0.10} _{-0.08} pF	50 V max.	-55 to +125 °C

(1) Capacitance = The capacitance value shall be measured under the conditions specified below.
 Frequency : 1 MHz±10 %, Voltage : 1 Vrms±0.2 Vrms, Temperature : 25 °C±2 °C

Performance

Test Item	Performance Requirements	Test Conditions
Peak Voltage	1000 V max.	ISO10605, air discharge 15 kV, Peak voltage value
Leakage Current	1 µA max.	Current at Rated voltage (DC 50 V)
ESD withstanding	Leakage current 10 µA max.	ISO10605, air discharge 25 kV, +/- 50 times
Rapid Change of Temperature	Leakage current 10 µA max.	-55 °C (30 min.)/+125 °C (30 min.), 100 cycles
Load Life in Humidity	Leakage current 10 µA max.	85 °C, 85%RH, Rated voltage, 1000 h
Endurance at 125 °C	Leakage current 10 µA max.	125 °C, Rated voltage, 1000 h
Resistance to Soldering Heat	Leakage current 10 µA max.	270 °C, 10 s

Frequency Characteristics

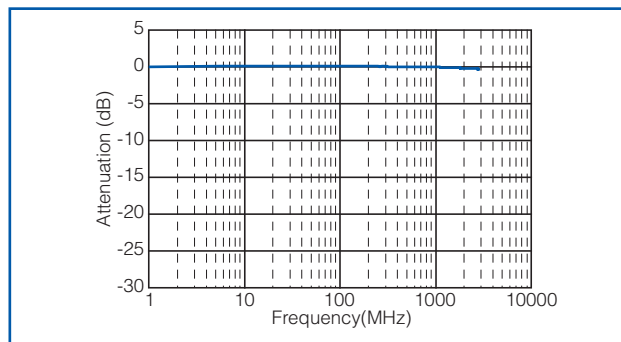

ESD Suppression Voltage Waveform

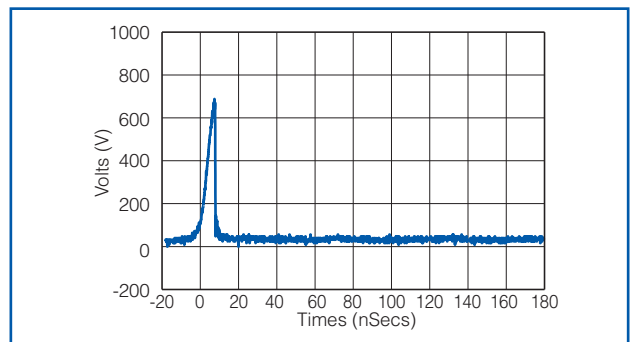

Typical Circuits Requiring Protection

● Automotive network (CAN, Ethernet)

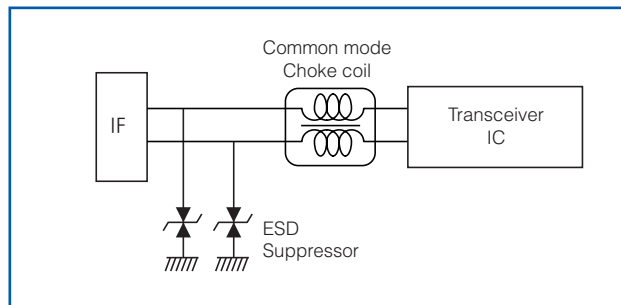

● Automotive antenna

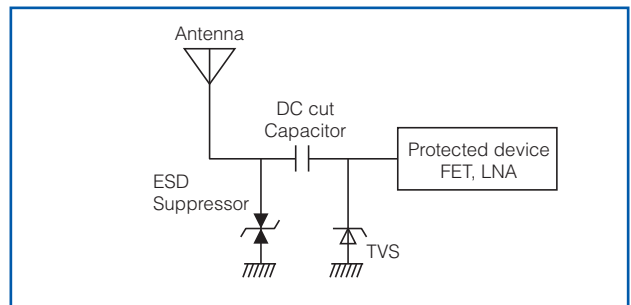

Recommended Land Pattern

Recommended land pattern design for ESD Suppressor is shown below.

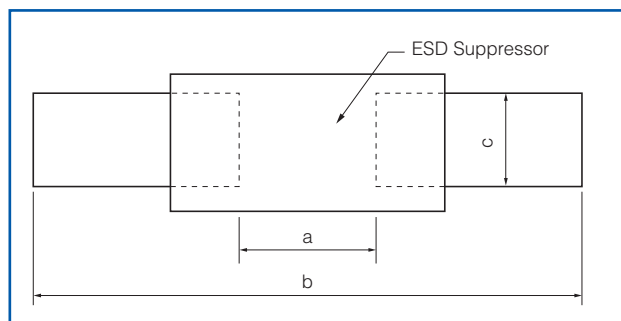

Part Number (inch size)	Dimensions (mm)		
	a	b	c
EZAEG3W (0603)	0.8 to 1.0	2.0 to 2.6	0.8 to 1.0

■ As for Packaging Methods, Soldering Conditions and Safety Precautions,

Please see Data Files

Packaging Methods (Taping)

● Standard Quantity

Part Number	Size (inch)	Kind of Taping	Pitch (P ₁)	Quantity
EZAEG1N	0201	Pressed Carrier Taping	2 mm	15,000 pcs./reel
EZAEG2A,2N	0402			10,000 pcs./reel
EZAEG3A	0603	Punched Carrier Taping	4 mm	5,000 pcs./reel
EZAEG3W	0603			4,000 pcs./reel
EZAEGCA	0805			5,000 pcs./reel

● Carrier Taping (Unit : mm)

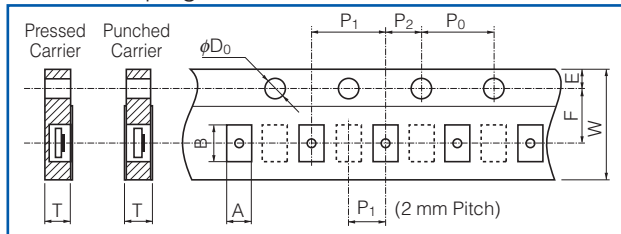

Part Number	A	B	W	F	E
EZAEG1N	0.38 ^{+0.05}	0.68 ^{+0.05}	8.00 ^{+0.20}	3.50 ^{+0.05}	1.75 ^{+0.10}
EZAEG2A,2N	0.70 ^{+0.05}	1.20 ^{+0.05}			
EZAEG3A	1.10 ^{+0.10}	1.90 ^{+0.10}	8.00 ^{+0.20}	3.50 ^{+0.05}	1.75 ^{+0.10}
EZAEG3W	0.91 ^{+0.10}	1.82 ^{+0.10}			
EZAEGCA	1.55 ^{+0.15}	2.30 ^{+0.20}			

Part Number	P ₁	P ₂	P ₀	φD ₀	T
EZAEG1N	2.00 ^{+0.10}	2.00 ^{+0.05}	4.00 ^{+0.10}	1.50 ^{+0.10}	0.42 ^{+0.05}
EZAEG2A,2N					0.60 ^{+0.05}
EZAEG3A	4.00 ^{+0.10}	2.00 ^{+0.05}	4.00 ^{+0.10}	1.50 ^{+0.10}	0.70 ^{+0.05}
EZAEG3W					1.08 ^{+0.10}
EZAEGCA					0.85 ^{+0.05}

● Taping Reel (Unit : mm)

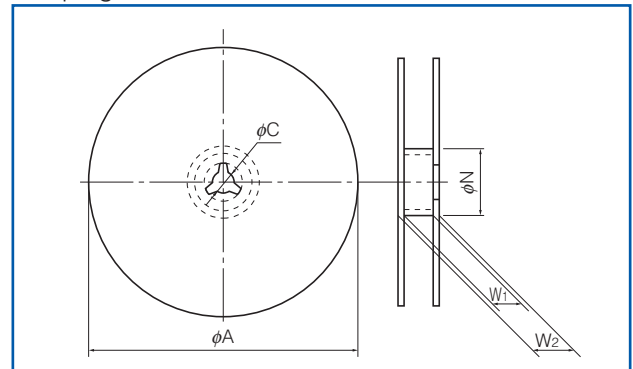

Part Number	φA	φN	φC	W ₁	W ₂
EZAEG1N	180.0 ⁰ _{-1.5}	60.0 ^{+1.0} ₀	13.0 ^{+0.2}	9.0 ^{+1.0} ₀	11.4 ^{+1.0}
EZAEG2A,2N					
EZAEG3A					
EZAEG3W					
EZAEGCA					

Recommended Soldering Conditions

Recommendations and precautions are described below

- Recommended soldering conditions for reflow
 - Reflow soldering shall be performed a maximum of two times.
 - Please contact us for additional information when used in conditions other than those specified.
 - Please measure the temperature of the terminals and study every kind of solder and printed circuit board for solderability before actual use.

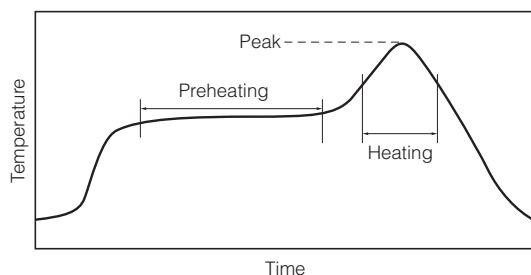

For soldering (Example : Sn/Pb)

	Temperature	Time
Preheating	140 °C to 160 °C	60 s to 120 s
Main heating	Above 200 °C	30 s to 40 s
Peak	235 ± 5 °C	max. 10 s

For lead-free soldering (Example : Sn/Ag/Cu)

	Temperature	Time
Preheating	150 °C to 180 °C	60 s to 120 s
Main heating	Above 230 °C	30 s to 40 s
Peak	max. 260 °C	max. 10 s

⚠ Safety Precautions

The following are precautions for individual products. Please also refer to the common precautions for ESD Suppressor in this catalog.

1. If a large electric surge (especially, one which is larger than an ESD) is expected to be applied, be sure to test and confirm proper ESD Suppressor (hereafter called the suppressors) functionality when mounted on your board. When the applied load is more than the allowable rated power under normal load conditions, it may impair performance and/or the reliability of the suppressors. Never exceed the rated power. If the product will be used under these special conditions, be sure to contact a Panasonic representative first.
2. Do not use halogen-based or other high-activity flux. Otherwise, the residue may impair the suppressors' performance and/or reliability.
3. When soldering with a soldering iron, never touch the suppressors' bodies with the tip of the soldering iron. When using a soldering iron with a high temperature tip, finish soldering as quickly as possible (within three seconds at 350 °C max.).
4. Avoid excessive bending of printed circuit boards in order to protect the suppressors from abnormal stress.
5. Do not immerse the suppressors in solvent for a long time. Before using solvent, carefully check the effects of immersion.
6. The suppressors, including the solderability, is guaranteed for a year from the date of arrival at your company, provided that they remain packed as they were when delivered and stored at a temperature of 5 °C to 35 °C and a relative humidity of 45 % to 85 %.

Multilayer Varistor (Automotive Grade)

Series: **EZJZ-M, EZJP-M**

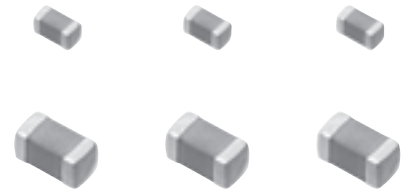

Features

- Excellent ESD suppression due to original advanced material technology
- Having large electrostatic resistance meeting IEC61000-4-2, ISO10605
- Having no polarity (bipolar) facilitated replacing Zener Diodes. Capable of replacing 2 Zener Diodes and 1 Capacitor.
- Lead-free plating terminal electrodes enabling great solderability
- Wide range of products is available by adopting multilayer structure, meeting various needs.
- AEC-Q200 qualified
- RoHS compliant

As for Packaging Methods, Handling Precautions

Please see Data Files

Explanation of Part Numbers

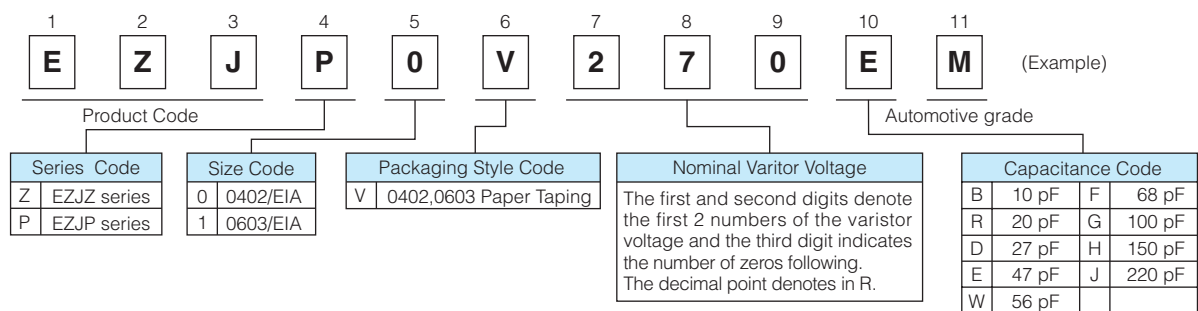

Construction

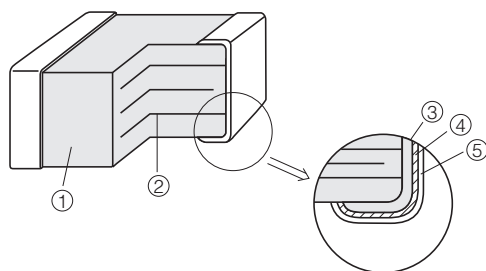

No.	Name	
①	Zinc oxide-based ceramics	
②	Internal electrode	
③	Terminal electrode	Substrate electrode
④		Intermediate electrode
⑤		External electrode

Dimensions in mm (not to scale)

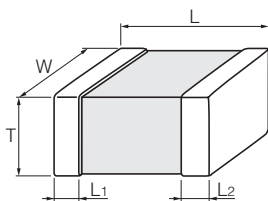

Size Code	Size(inch)	L	W	T	L ₁ , L ₂
0	0402/EIA	1.00±0.05	0.50±0.05	0.50±0.05	0.2±0.1
1	0603/EIA	1.6±0.1	0.8±0.1	0.8±0.1	0.3±0.2

Features

Wide variety of products is available by adopting multilayer construction, which achieved wide range of usage, such as application to DC voltage lines and signal lines.

- Circuit voltage

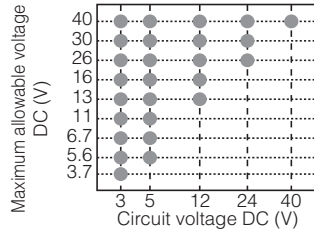

- Varistor voltage : 18 to 100 V [at 1m A]
- Capacitance : 10 to 220 pF max. [at 1M Hz]

Recommended Applications

- Engine ECU
- Various body ECU
- Communication line, such as CAN, LIN
- Audio, Navigation
- LED Light
- Control SW

Ratings and Characteristics

Size	Part No.	Maximum allowable voltage DC (V)	Nominal varistor voltage at 1m A (V)	Capacitance (pF)		Maximum peak current at 8/20 μ s, 2 times (A)	Maximum ESD	
				at 1M Hz	at 1k Hz		IEC61000-4-2 150p F/ 330 Ω	ISO10605 330p F/ 2k Ω
0402 /EIA	EZJP0V180HM	11	18	150 max. [120 typ.]	140 typ.	10	Contact discharge 8k V	Contact discharge 25k V
	EZJP0V220HM	13	22	150 max. [100 typ.]	116 typ.	10		
	EZJP0V270GM	18	27	100 max. [85 typ.]	100 typ.	10		
	EZJP0V270EM	18	27	47 max. [33 typ.]	37 typ.	4		
	EZJP0V270RM	18	27	20 max. [15 typ.]	16.5 typ.	2		
	EZJP0V270BM	18	27	10 max. [8 typ.]	10 typ.	–		
	EZJP0V330GM	25	33	100 max. [85 typ.]	100 typ.	10		
	EZJP0V420WM	30	42	56 max. [40 typ.]	45 typ.	6		
	EZJP0V650DM	40	65	27 max. [22 typ.]	33 typ.	2		
EZJP0V101BM	30	100	10 max. [8 typ.]	10 typ.	–			
0603 /EIA	EZJP1V180JM	11	18	220 max. [180 typ.]	210 typ.	20		
	EZJP1V220JM	13	22	220 max. [160 typ.]	185 typ.	10		
	EZJP1V270GM	18	27	100 max. [85 typ.]	100 typ.	10		
	EZJP1V270EM	18	27	47 max. [33 typ.]	37 typ.	5		
	EZJP1V270RM	18	27	20 max. [15 typ.]	16.5 typ.	2		
	EZJP1V330GM	25	33	100 max. [85 typ.]	100 typ.	10		
	EZJP1V420FM	30	42	68 max. [55 typ.]	63 typ.	8		
	EZJP1V650DM	40	65	27 max. [22 typ.]	33 typ.	2		
	EZJZ1V180JM	11	18	220 max. [180 typ.]	210 typ.	20		
	EZJZ1V220JM	13	22	220 max. [160 typ.]	185 typ.	20		
	EZJZ1V270GM	16	27	100 max. [85 typ.]	100 typ.	20		
	EZJZ1V330GM	26	33	100 max. [85 typ.]	100 typ.	20		
EZJZ1V420FM	30	42	68 max. [55 typ.]	63 typ.	15			
EZJZ1V650DM	40	65	27 max. [22 typ.]	33 typ.	5			

- Operating Temperature Range : EZJP serie –55 to 150 °C
EZJZ serie –55 to 125 °C
- * Recommend soldering method : Reflow soldering

Maximum Allowable Voltage	Maximum DC Voltage that can be applied continuously within the operating temperature range
Varistor Voltage	Varistor starting voltage between terminals at DC 1 mA, also known as Breakdown voltage
Maximum Peak Current	Maximum current that can be withstood under the standard pulse 8/20 μ s, 2 times based
Maximum ESD	Maximum voltage that can be withstood under ESD

Varistor Characteristics and Equivalent Circuit

A Multilayer Varistor does not have an electrical polarity like zener diodes and is equivalent to total 3 pcs. of 2 zener diodes and 1 capacitor.

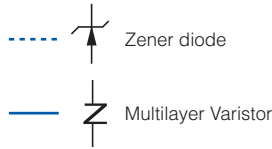
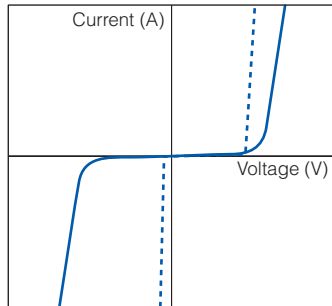

[Equivalent Circuit]

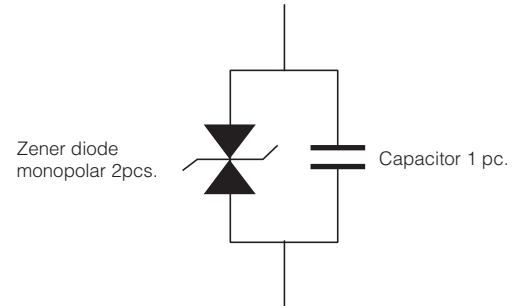

ESD Suppressive Effects

Typical effects of ESD suppression

Test conditions: IEC61000-4-2* Level 4 Contact discharge, 8k V

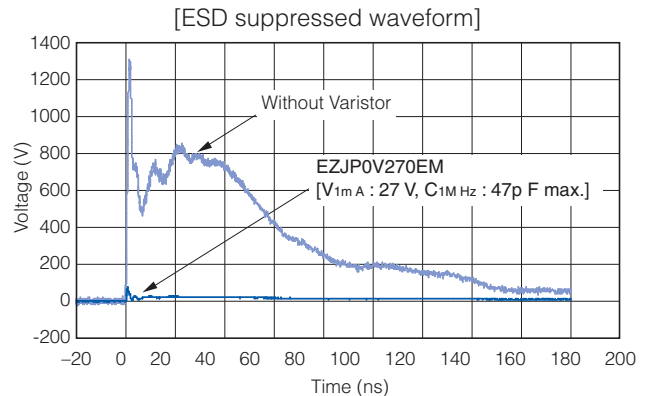
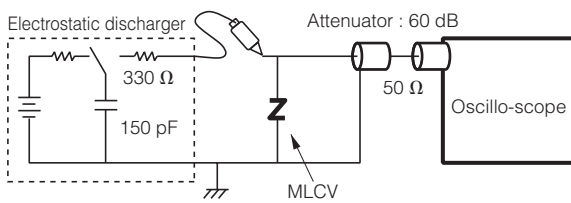

* IEC61000-4-2 ... International Standard of the ESD testing method (HBM) for electronic equipment ability to withstand ESD generated from a human body. It sets 4 levels of severity

Severity	Level 1	Level 2	Level 3	Level 4
Contact discharge	2k V	4k V	6k V	8k V
Air discharge	2k V	4k V	8k V	15k V

Replacement of Zener diode

Replacing "Zener diode and Capacitor" with Multilayer Varistor saves both the mounting area and number of components used.

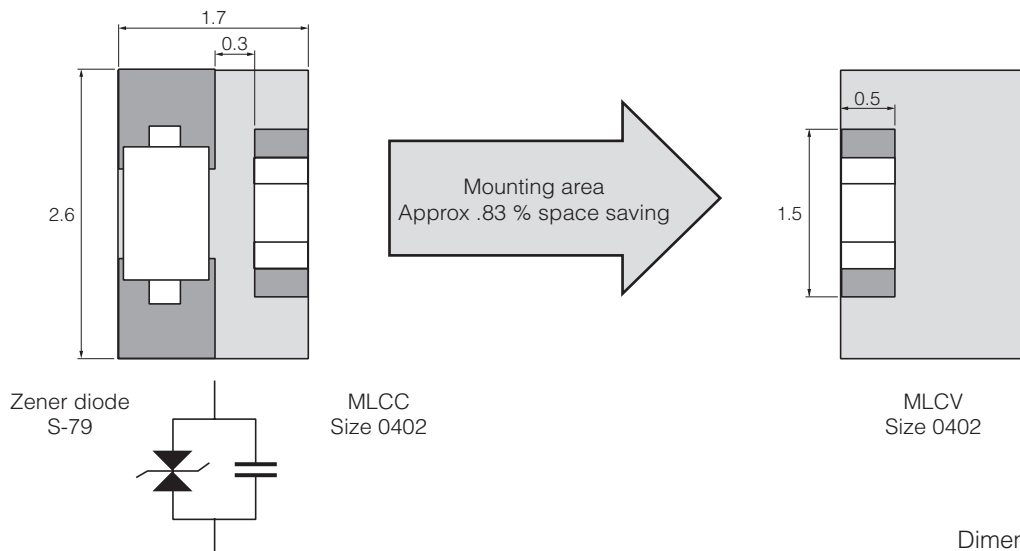

Dimensions in mm

Performance and Testing Methods

Characteristics	Specifications	Testing Method															
Standard test conditions		Electrical characteristics shall be measured under the following conditions. Temp. : 5 to 35 °C, Relative humidity : 85 % or less															
Varistor voltage	To meet the specified value.	The Varistor voltage is the voltage (V_c or V_{cmA}) between both end terminals of a Varistor when specified current (CmA) is applied to it. The measurement shall be made as quickly as possible to avoid heating effects.															
Maximum allowable voltage	To meet the specified value.	The maximum DC voltage that can be applied continuously to a varistor.															
Capacitance	To meet the specified value.	Capacitance shall be measured at the specified frequency, bias voltage 0 V, and measuring voltage 0.2 to 2 Vrms.															
Maximum peak current	To meet the specified value.	The maximum current measured (Varistor voltage tolerance is within $\pm 10\%$) when a standard impulse current of 8/20 μ seconds is applied twice with an interval of 5 minutes.															
Maximum ESD	To meet the specified value.	The maximum ESD measured (while the varistor voltage is within blow ranges of its nominal value) when exposed to ESD 10 times (five times for each positive negative polarity) based on IEC61000-4-2, ISO10605. EZJP □□□□□□□□M : within $\pm 10\%$, EZJZ □□□□□□□□M : within $\pm 30\%$															
Solder ability	To meet the specified value.	The part shall be immersed into a soldering bath under the conditions below. Solder : Sn-Ag-Cu Soldering flux : Ethanol solution of rosin (Concentration approx. 25 wt%) Soldering temp. : 230 \pm 5 °C Period : 4 \pm 1 s Soldering position : Immerse both terminal electrodes until they are completely into the soldering bath.															
Resistance to soldering heat	$\Delta V_c / V_c$: within $\pm 10\%$	After the immersion, leave the part for 24 \pm 2 hours under the standard condition, then evaluate its characteristics. Soldering conditions are specified below: Soldering conditions : 270 °C, 3 s / 260 °C, 10 s Soldering position : Immerse both terminal electrodes until they are completely into the soldering bath.															
Temperature cycling	$\Delta V_c / V_c$: within $\pm 10\%$	After repeating the cycles stated below for specified number of times, leave the part for 24 \pm 2 hours, then evaluate its characteristics. Cycle : 2000 cycle <table border="1" style="margin-left: auto; margin-right: auto;"> <thead> <tr> <th>Step</th> <th>Temperature</th> <th>Period</th> </tr> </thead> <tbody> <tr> <td>1</td> <td>Max. Operating Temp.</td> <td>30\pm3 min</td> </tr> <tr> <td>2</td> <td>Ordinary temp.</td> <td>3 min max.</td> </tr> <tr> <td>3</td> <td>Min. Operating Temp.</td> <td>30\pm3 min</td> </tr> <tr> <td>4</td> <td>Ordinary temp.</td> <td>3 min max.</td> </tr> </tbody> </table>	Step	Temperature	Period	1	Max. Operating Temp.	30 \pm 3 min	2	Ordinary temp.	3 min max.	3	Min. Operating Temp.	30 \pm 3 min	4	Ordinary temp.	3 min max.
Step	Temperature	Period															
1	Max. Operating Temp.	30 \pm 3 min															
2	Ordinary temp.	3 min max.															
3	Min. Operating Temp.	30 \pm 3 min															
4	Ordinary temp.	3 min max.															
Vibration	$\Delta V_c / V_c$: within $\pm 10\%$	The varistor shall be soldered on the testing board shown in Fig.3. G force : 5 G Vibration frequency range : 10 to 2000 Hz Sweet time : 20 min. Sweet direction : 12 cycles for 3 courses perpendicular each other															
Mechanical Shock	$\Delta V_c / V_c$: within $\pm 10\%$	The varistor shall be soldered on the testing board shown in Fig.3. Shock-wave formation : Half sine G force : 50 G Shock direction : 6 directions of X, Y, Z, for each three times															
Biased Humidity	$\Delta V_c / V_c$: within $\pm 10\%$	After conducting the test under the conditions specified below, leave the part 24 \pm 2 hours, then evaluate its characteristics. Temp. : 85 \pm 2 °C Humidity : 80 to 85 %RH Applied voltage : Maximum allowable voltage (Individually specified) Period : 2000+24 / 0 h															
High temperature exposure (dry heat)	$\Delta V_c / V_c$: within $\pm 10\%$	After conducting the test under the conditions specified below, leave the part 24 \pm 2 hours, then evaluate its characteristics. Temp. : Maximum operating temperature ± 3 °C (Individually specified) Applied voltage : Maximum allowable voltage (Individually specified) Period : 2000+24 / 0h															

Packaging Methods

- Standard Packing Quantity

Series	Size Code	Thickness (mm)	Kind of Taping	Pitch (mm)	Q'ty (pcs./reel)
EZJZ, EZJP	0 (0402)	0.5	Punched Carrier Taping	2	10,000
	1 (0603)	0.8		4	4,000

- Pitch 2mm (Punched Carrier Taping) : Size 0402

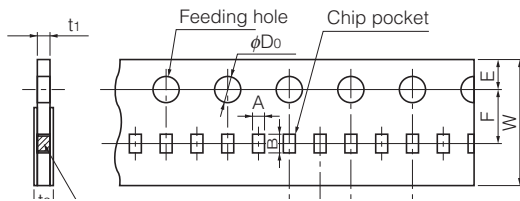

Symbol	A	B	W	F	E	P ₁	P ₂	P ₀	φD ₀	t ₁	t ₂
Dim (mm)	0.62 ±0.05	1.12 ±0.05	8.0 ±0.2	3.50 ±0.05	1.75 ±0.10	2.00 ±0.05	2.00 ±0.05	4.0 ±0.1	1.5 +0.1/0	0.7 max.	1.0 max.

- Pitch 4mm (Punched Carrier Taping) : Size 0603

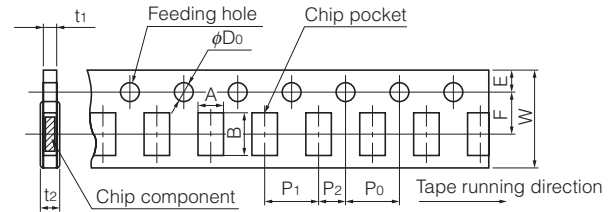

Symbol	A	B	W	F	E	P ₁	P ₂	P ₀	φD ₀	t ₁	t ₂
Dim (mm)	1.0 ±0.1	1.8 ±0.1	8.0 ±0.2	3.50 ±0.05	1.75 ±0.10	4.0 ±0.1	2.00 ±0.05	4.0 ±0.1	1.5 +0.1/0	1.1 max.	1.4 max.

- Reel for Taping

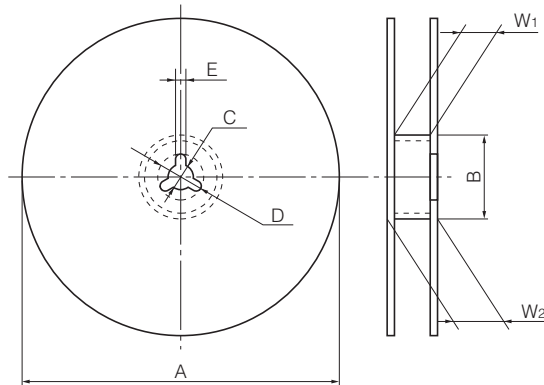

Symbol	A	B	C	D	E	W ₁	W ₂
Dima (mm)	φ180 ⁻³	φ60.0 ^{+1.0} ₀	13.0±0.5	21.0±0.8	2.0±0.5	9.0 ^{+1.0} ₀	11.4±1.0

- Leader Part and Taped End

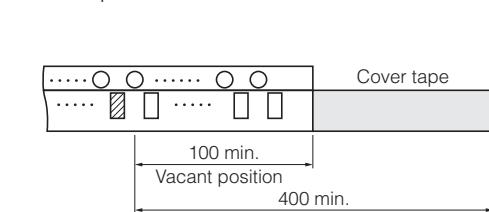

Tape end

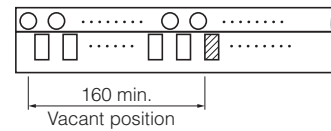

Dimensions in mm

Multilayer Varistors, Chip Type (Automotive Grade)

Series: **EZJZ-M, EZJP-M**

Handling Precautions

⚠ Safety Precautions

Multilayer Varistors for Automotive (hereafter referred to as “Varistors”) should be used for general purpose applications as countermeasures against ESD and noise found in vehicle electronics (Engine ECU and various body ECU, accessory equipment, etc.) equipment. When subjected to severe electrical, environmental, and/or mechanical stress beyond the specifications, as noted in the Ratings and Specified Conditions section, the Varistors’ performance may be degraded, or become failure mode, such as short circuit mode and open-circuit mode.

If you use under the condition of short-circuit, heat generation of Varistors will occur by running large current due to application of voltage. There are possibilities of smoke emission, substrate burn-out, and, in the worst case, fire.

For products which require high safety levels, please carefully consider how a single malfunction can affect your product. In order to ensure the safety in the case of a single malfunction, please design products with fail-safe, such as setting up protecting circuits, etc.

- For the following applications and conditions, please contact us for additional specifications, which is not found in this document.
 - When your application may have difficulty complying with the safety or handling precautions specified below.
 - High-quality and high-reliability required devices that have possibility of causing hazardous conditions, such as death or injury (regardless of directly or indirectly), due to failure or malfunction of the product.
 - ① Aircraft and Aerospace Equipment (artificial satellite, rocket, etc.)
 - ② Submarine Equipment (submarine repeating equipment, etc.)
 - ③ Transportation Equipment (airplanes, trains, ship, traffic signal controllers, etc.)
 - ④ Power Generation Control Equipment (atomic power, hydroelectric power, thermal power plant control system, etc.)
 - ⑤ Medical Equipment (life-support equipment, pacemakers, dialysis controllers, etc.)
 - ⑥ Information Processing Equipment (large scale computer systems, etc.)
 - ⑦ Electric Heating Appliances, Combustion devices (gas fan heaters, oil fan heaters, etc.)
 - ⑧ Rotary Motion Equipment
 - ⑨ Security Systems
 - ⑩ And any similar types of equipment

⚠ Strict Observance

1. Confirmation of Rated Performance

The Varistors shall be operated within the specified rating/performance.

Applications exceeding the specifications may cause deteriorated performance and/or breakdown, resulting in degradation and/or smoking or ignition of products. The following are strictly observed.

- (1) The Varistors shall not be operated beyond the specified operating temperature range.
- (2) The Varistors shall not be operated in excess of the specified maximum allowable voltage.
- (3) The Varistors shall not be operated in the circuits to which surge current and ESD that exceeds the specified maximum peak current and maximum ESD.
- (4) Never use for AC power supply circuits.

2. The Varistors shall not be mounted near flammables.

Operating Conditions and Circuit Design

1. Circuit Design

1.1 Operating Temperature and Storage Temperature

When operating a components-mounted circuit, please be sure to observe the “Operating Temperature Range”, written in delivery specifications. Storage temperature of PCB after mounting Varistors, which is not operated, should be within the specified “Storage Temperature Range” in the delivery specifications. Please remember not to use the product under the condition that exceeds the specified maximum temperature.

1.2 Operating Voltage

The Varistors shall not be operated in excess of the “Maximum allowable voltage”. If the Varistors are operated beyond the specified Maximum allowable voltage, it may cause short and/or damage due to thermal run away.

The circuit that continuously applies high frequency and/or steep pulse voltage please examines the reliability of the Varistor even if it is used within a “Maximum allowable voltage”. Also, it would be safer to check also the safety and reliability of your circuit.

1.3 Self-heating

The surface temperature of the Varistors shall be under the specified Maximum Operating Temperature in the Specifications including the temperature rise caused by self-heating. Check the temperature rise of the Varistor in your circuit.

1.4 Environmental Restrictions

The Varistors shall not be operated and/or stored under the following conditions.

- (1) Environmental conditions
 - (a) Under direct exposure to water or salt water
 - (b) Under conditions where water can condense and/or dew can form
 - (c) Under conditions containing corrosive gases such as hydrogen sulfide, sulfurous acid, chlorine and ammonia
- (2) Mechanical conditions

The place where vibration or impact that exceeds specified conditions written in delivery specification is loaded.

2. Design of Printed Circuit Board

2.1 Selection of Printed Circuit Boards

There is a possibility of performance deterioration by heat shock (temperature cycles), which causes cracks, from alumina substrate.

Please confirm that the substrate you use does not deteriorate the Varistors' quality.

2.2 Design of Land Pattern

- (1) Recommended land dimensions are shown below. Use the proper amount of solder in order to prevent cracking. Using too much solder places excessive stress on the Varistors.

Recommended Land Dimensions

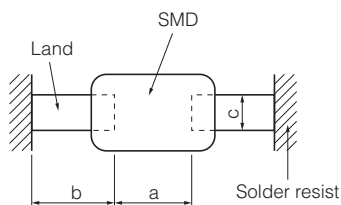

Unit (mm)

Size Code (EIA)	Component dimensions			a	b	c
	L	W	T			
0(0402)	1.0	0.5	0.5	0.4 to 0.5	0.4 to 0.5	0.4 to 0.5
1(0603)	1.6	0.8	0.8	0.8 to 1.0	0.6 to 0.8	0.6 to 0.8

- (2) The land size shall be designed to have equal space, on both right and left side. If the amount of solder on the right land is different from that of the left land, the component may be cracked by stress since the side with a larger amount of solder solidifies later during cooling.

Recommended Amount of Solder

- (a) Excessive amount (b) Proper amount (c) Insufficient amount

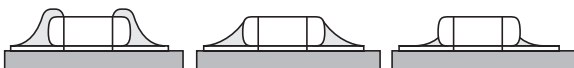

2.3 Utilization of Solder Resist

- (1) Solder resist shall be utilized to equalize the amounts of solder on both sides.
- (2) Solder resist shall be used to divide the pattern for the following cases;
 - Components are arranged closely.
 - The Varistor is mounted near a component with lead wires.
 - The Varistor is placed near a chassis.
 See the table below.

Prohibited Applications and Recommended Applications

Item	Prohibited applications	Improved applications by pattern division
Mixed mounting with a component with lead wires	The lead wire of a Component With lead wires	Solder resist
Arrangement near chassis	Chassis Solder (ground solder) Electrode pattern	Solder resist
Retro-fitting of component with lead wires	Soldering iron A lead wire of Retrofitted component	Solder resist
Lateral arrangement	Portion to be Excessively soldered Land	Solder resist

2.4 Component Layout

To prevent the crack of Varistors, place it on the position that could not easily be affected by the bending stress of substrate while going through procedures after mounting or handling.

- (1) To minimize mechanical stress caused by the warp or bending of a PC board, please follow the recommended Varistors' layout below.

Prohibited layout	Recommended layout
	 Layout the Varistors sideways against the stressing direction.

- (2) The following layout is for your reference since mechanical stress near the dividing/breaking position of a PC board varies depending on the mounting position of the Varistors.

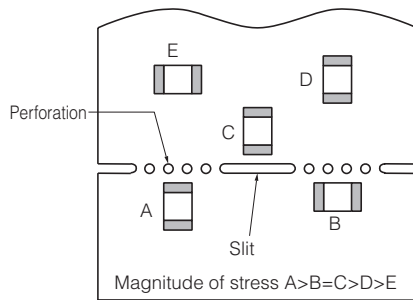

- (3) The magnitude of mechanical stress applied to the Varistors when dividing the circuit board in descending order is as follows: push back < slit < V-groove < perforation. Also take into account the layout of the Varistors and the dividing/breaking method.

2.5 Mounting Density and Spaces

Intervals between components should not be too narrow to prevent the influence from solder bridges and solder balls. The space between components should be carefully determined.

Precautions for Assembly

1. Storage

- (1) The Varistors shall be stored between 5 to 40 °C and 20 to 70 % RH, not under severe conditions of high temperature and humidity.
- (2) If stored in a place where humidity, dust, or corrosive gasses (hydrogen sulfide, sulfurous acid, hydrogen chloride and ammonia, etc.) are contained, the solderability of terminals electrodes will be deteriorated.

In addition, storage in a place where the heat or direct sunlight exposure occurs will causes mounting problems due to deformation of tapes and reels and components and taping/reels sticking together.

- (3) Do not store components longer than 6 months. Check the solderability of products that have been stored for more than 6 months before use.

2. Adhesives for Mounting

- (1) The amount and viscosity of an adhesive for mounting shall be such that the adhesive will not flow off on the land during its curing.
- (2) If the amount of adhesive is insufficient for mounting, the Varistors may fall off after or during soldering.
- (3) Low-viscosity of the adhesive causes displacement of Varistors.

- (4) The heat-curing methods for adhesive are ultraviolet radiation, far-infrared radiation, and so on. In order to prevent the terminal electrodes of the Varistors from oxidizing, the curing shall be under the following conditions:
160 °C max., for 2 minutes max.

- (5) Insufficient curing may cause the Varistors to fall off after or during soldering. In addition, insulation resistance between terminal electrodes may deteriorate due to moisture absorption. In order to prevent these problems, please observe proper curing conditions.

3. Chip Mounting Consideration

- (1) When mounting the Varistors components on a PC board, the Varistor bodies shall be free from excessive impact loads such as mechanical impact or stress due to the positioning, pushing force and displacement of vacuum nozzles during mounting.
- (2) Maintenance and inspection of the Chip Mounter must be performed regularly.
- (3) If the bottom dead center of the vacuum nozzle is too low, the Varistor will crack from excessive force during mounting.

Please refer to the following precautions and recommendations.

- (a) Set and adjust the bottom dead center of the vacuum nozzles to the upper surface of the PC board after correcting the warp of the PC board.
- (b) Set the pushing force of the vacuum nozzle during mounting to 1 to 3 N in static load.
- (c) For double surface mounting, apply a supporting pin on the rear surface of the PC board to suppress the bending of the PC board in order to minimize the impact of the vacuum nozzles. Typical examples are shown in the table below.
- (d) Adjust the vacuum nozzles so that their bottom dead center during mounting is not too low.

Item	Prohibited mounting	Recommended mounting
Single surface mounting		
Double surface mounting		

- (4) The closing dimensions of the positioning chucks shall be controlled. Maintenance and replacement of positioning chucks shall be performed regularly to prevent chipping or cracking of the Varistors caused by mechanical impact during positioning due to worn positioning chucks.
- (5) Maximum stroke of the nozzle shall be adjusted so that the maximum bending of PC board does not exceed 0.5 mm at 90 mm span. The PC board shall be supported by an adequate number of supporting pins.

4. Selection of Soldering Flux

Soldering flux may seriously affect the performance of the Varistors. Please confirm enough whether the soldering flux have an influence on performance of the Varistors or not, before using.

5. Soldering

5.1 Flow Soldering

When conducting flow soldering, stress from abrupt temperature change is applied to the Varistors, so the temperature, especially temperature of solder should be controlled very carefully. Varistors should not be subjected to abrupt temperature change because it causes occurrence of thermal cracks as a result of excessive thermal stress inside of the Varistors from flow soldering. You should be careful to temperature difference. Therefore it is essential that soldering process follow these recommended conditions.

(1) Application of Soldering flux :

The soldering flux shall be applied to the mounted Varistors thinly and uniformly by foaming method.

(2) Preheating :

Conduct sufficient pre-heating, and make sure that the temperature difference between solder and Varistors' surface is 150 °C or less.

(3) Immersion into Soldering bath :

The Varistors shall be immersed into a soldering bath of 240 to 260 °C for 3 to 5 seconds.

(4) Gradual Cooling :

After soldering, avoid rapid cooling (forced cooling) and conduct gradual cooling, so that thermal cracks do not occur.

(5) Flux Cleaning :

When the Varistors are immersed into a cleaning solvent, be sure that the surface temperatures of devices do not exceed 100 °C.

(6) Performing flow soldering once under the conditions shown in the figure on the right "Recommended profile of Flow soldering (Ex.)" will not cause any problems. However, pay attention to the possible warp and bending of the PC board.

Recommended profile of Flow soldering (Ex.)

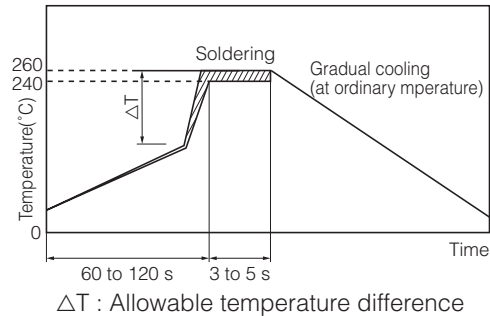

For products specified in individual specifications, avoid flow soldering.

5.2 Reflow Soldering

The reflow soldering temperature conditions are composed of temperature curves of Preheating, Temp. rise, Heating, Peak and Gradual cooling. Large temperature difference inside the Varistors caused by rapid heat application to the Varistors may lead to excessive thermal stresses, contributing to the thermal cracks. The Preheating temperature requires controlling with great care so that tombstone phenomenon may be prevented.

Item	Temperature	Period or Speed
① Preheating	140 to 180 °C	60 to 120 s
② Temp. rise	Preheating temp to Peak temp.	2 to 5 °C /s
③ Heating	220 °C min.	60 s max.
④ Peak	260 °C max.	10 s max.
⑤ Gradual cooling	Peak temp. to 140 °C	1 to 4 °C /s

Recommended profile of Reflow soldering (Ex.)

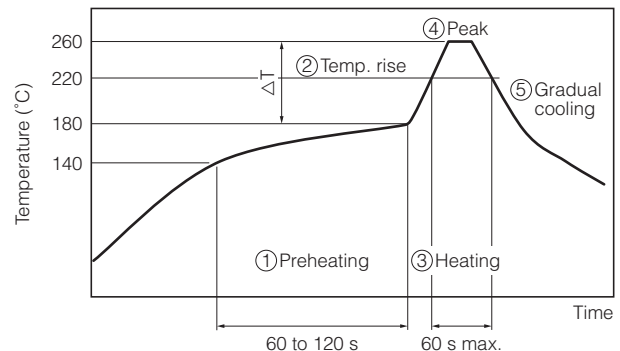

The rapid cooling (forced cooling) during Gradual cooling part should be avoided, because this may cause defects such as the thermal cracks, etc. When the Varistors are immersed into a cleaning solvent, make sure that the surface temperatures of the devices do not exceed 100 °C. Performing reflow soldering twice under the conditions shown in the figure above "Recommended profile of Reflow soldering (Ex.)" will not cause any problems. However, pay attention to the possible warp and bending of the PC board.

5.3 Hand Soldering

Hand soldering typically causes significant temperature change, which may induce excessive thermal stresses inside the Varistors, resulting in the thermal cracks, etc.

In order to prevent any defects, the following should be observed.

- Control the temperature of the soldering tips with special care.
- Avoid the direct contact of soldering tips with the Varistors and/or terminal electrodes.
- Do not reuse dismantled Varistors.

(1) Condition 1 (with preheating)

(a) Soldering :

Use thread solder ($\phi 1$ mm or below) which contains flux with low chlorine, developed for precision electronic equipment.

(b) Preheating :

Conduct sufficient Preheating, and make sure that the temperature difference between solder and Varistors' surface is 150 °C or less.

(c) Temperature of Iron tip: 350 °C max.

(The required amount of solder shall be melted in advance on the soldering tip.)

(d) Gradual cooling :

After soldering, the Varistors shall be cooled gradually at room temperature.

Recommended profile of Hand soldering (Ex.)

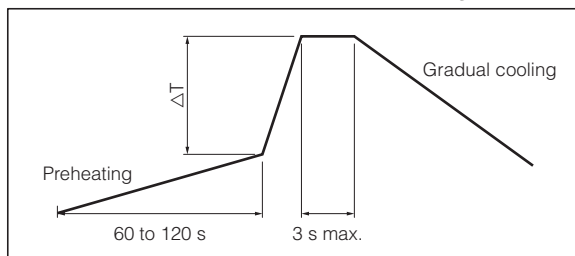

ΔT : Allowable temperature difference $\Delta T \leq 150$ °C

(2) Condition 2 (without preheating)

Hand soldering can be performed without preheating, by following the conditions below:

- (a) Soldering iron tip shall never directly touch the ceramic and terminal electrodes of the Varistors.
- (b) The lands are sufficiently preheated with a soldering iron tip before sliding the soldering iron tip to the terminal electrodes of the Varistors for soldering.

Conditions of Hand soldering without preheating

Item	Condition
Temperature of Iron tip	350 °C max.
Wattage	20 W max.
Shape of Iron tip	$\phi 3$ mm max.
Soldering time with a soldering iron	3 s max.

6. Post Soldering Cleaning

6.1 Cleaning solvent

Soldering flux residue may remain on the PC board if cleaned with an inappropriate solvent. This may deteriorate the performance of Varistors, especially insulation resistance.

6.2 Cleaning conditions

Inappropriate cleaning conditions such as insufficient cleaning or excessive cleaning may impair the electrical characteristics and reliability of the Varistors.

(1) Insufficient cleaning can lead to :

- (a) The halogen substance found in the residue of the soldering flux may cause the metal of terminal electrodes to corrode.
- (b) The halogen substance found in the residue of the soldering flux on the surface of the Varistors may change resistance values.
- (c) Water-soluble soldering flux may have more remarkable tendencies of (a) and (b) above compared to those of rosin soldering flux.

(2) Excessive cleaning can lead to :

- (a) When using ultrasonic cleaner, make sure that the output is not too large, so that the substrate will not resonate. The resonance causes the cracks in Varistors and/or solders, and deteriorates the strength of the terminal electrodes.

Please follow these conditions for Ultrasonic cleaning:

- Ultrasonic wave output : 20 W/L max.
- Ultrasonic wave frequency : 40 kHz max.
- Ultrasonic wave cleaning time : 5 min. max.

6.3 Contamination of Cleaning solvent

Cleaning with contaminated cleaning solvent may cause the same results as that of insufficient cleaning due to the high density of liberated halogen.

7. Inspection Process

The pressure from measuring terminal pins might bend the PCB when implementing circuit inspection after mounting Varistors on PCB, and as a result, cracking may occur.

- (1) Mounted PC boards shall be supported by an adequate number of supporting pins on the back with bend settings of 90 mm span 0.5 mm max.
- (2) Confirm that the measuring pins have the right tip shape, are equal in height, have the right pressure and are set in the correct positions. The following figures are for your reference to avoid bending the PC board.

	Prohibited setting	Recommended setting
Bending of PC board		

8. Protective Coating

When the surface of a PC board on which the Varistors have been mounted is coated with resin to protect against moisture and dust, it shall be confirmed that the protective coating does not affect the performance of Varistors.

- (1) Choose the material that does not emit the decomposition and/or reaction gas. The Gas may affect the composing members of the Varistors.
- (2) Shrinkage and expansion of resin coating when curing may apply stress to the Varistors and may lead to occurrence of cracks.

9. Dividing/Breaking of PC Boards

- (1) Please be careful not to stress the substrate with bending/twisting when dividing, after mounting components including Varistors. Abnormal and excessive mechanical stress such as bending or torsion shown below can cause cracking in the Varistors.

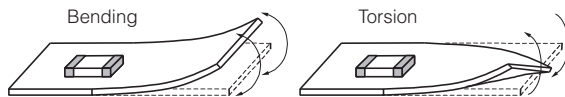

- (2) Dividing/Breaking of the PC boards shall be done carefully at moderate speed by using a jig or apparatus to prevent the Varistors on the boards from mechanical damage.
- (3) Examples of PCB dividing/breaking jigs:
The outline of PC board breaking jig is shown below. When PC board are broken or divided, loading points should be close to the jig to minimize the extent of the bending.
Also, planes with no parts mounted on should be used as plane of loading, in order to prevent tensile stress induced by the bending, which may cause cracks of the Varistors or other parts mounted on the PC boards.

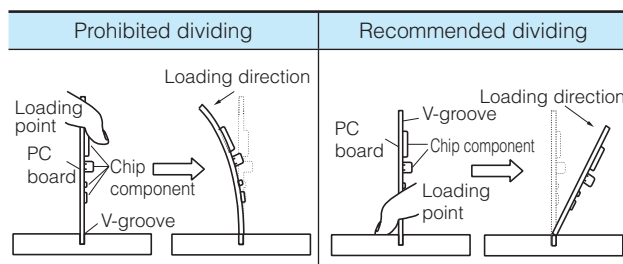
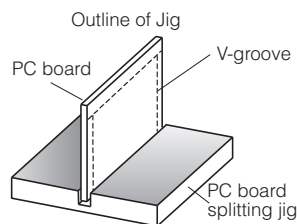

10. Mechanical Impact

- (1) The Varistors shall be free from any excessive mechanical impact. The Varistor body is made of ceramics and may be damaged or cracked if dropped. Never use a Varistor which has been dropped; their quality may already be impaired, and in that case, failure rate will increase.
- (2) When handling PC boards with Varistors mounted on them, do not allow the Varistors to collide with another PC board.

When mounted PC boards are handled or stored in a stacked state, the corner of a PC board might strike Varistors, and the impact of the strike may cause damage or cracking and can deteriorate the withstand voltage and insulation resistance of the Varistor.

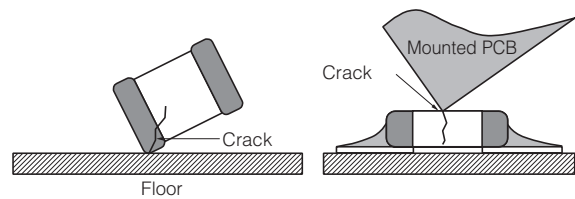

Other

The various precautions described above are typical. For special mounting conditions, please contact us.

Multilayer Varistor for ESD pulse [DC voltage lines/High speed signal lines]

Series: **EZJZ, EZJP**

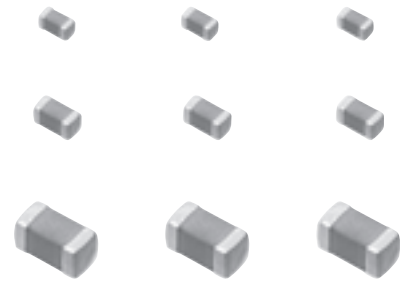

Features

- Excellent ESD suppression due to original advanced material technology
- Having large electrostatic resistance meeting IEC61000-4-2, Level 4 standard
- Having no polarity (bipolar) facilitated replacing Zener Diodes. Capable of replacing 2 Zener Diodes and 1 Capacitor.
- Lead-free plating terminal electrodes enabling great solderability
- Wide range of products is available by adopting multilayer structure, meeting various needs.
- Low capacitance versions for DC voltage lines of high speed busses
- Ultra low capacitance for high speed signal line
- Applicable to high-speed signal lines, such as interfaces (e.g. USB 2.0, IEEE1394, HDMI, and so on), due to our original ultra-low capacitance technology.
- RoHS compliant

As for Packaging Methods, Handling Precautions

Please see Data Files

Explanation of Part Numbers

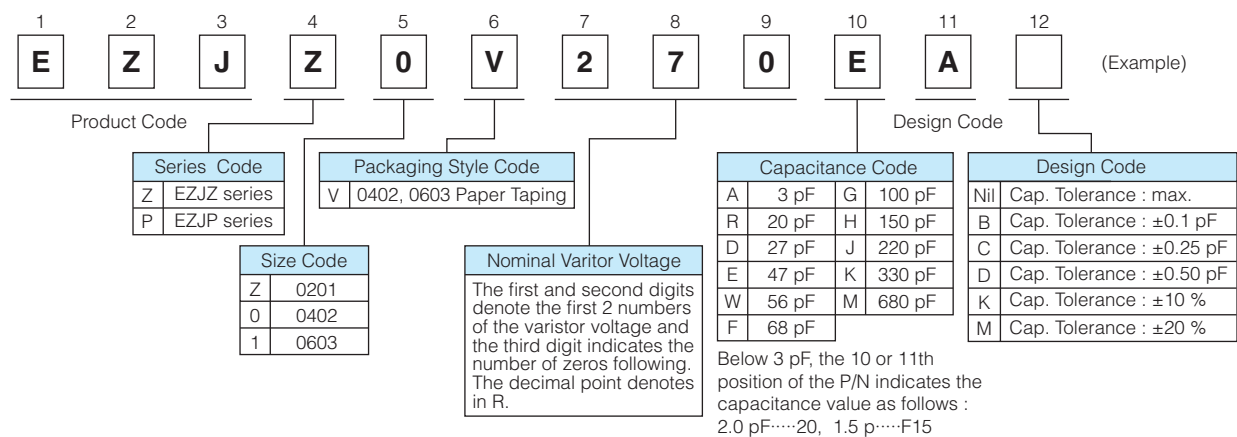

Construction

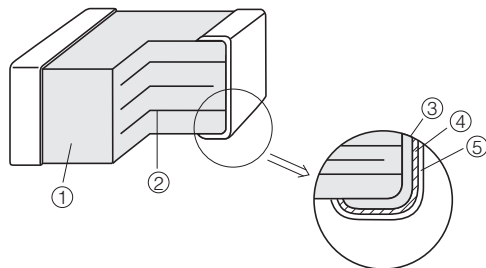

No.	Name
①	Semiconductive Ceramics
②	Internal electrode
③	Substrate electrode
④	Terminal electrode
⑤	External electrode

Dimensions in mm (not to scale)

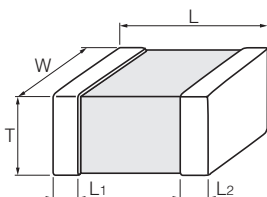

Size Code	Size(inch)	L	W	T	L ₁ , L ₂
Z	0201	0.60±0.03	0.30±0.03	0.30±0.03	0.15±0.05
0	0402	1.00±0.05	0.50±0.05	0.50±0.05	0.2±0.1
1	0603	1.6±0.1	0.8±0.1	0.8±0.1	0.3±0.2

Multilayer Varistor, Low Capacitance Type [High speed signal lines]

Features

- Multilayer monolithic ceramic construction for high speed signal lines
- Ideal for USB 2.0, IEEE1394, and HDMI high speed data busses
- Applicable to high-speed signal lines, such as interfaces (e.g. USB 2.0, IEEE1394, HDMI, and so on), due to our original material technology and multilayer technology.
- Capacitance: 0.8 to 2.1 pF typ.

Recommended Applications

Mobile phone	Antenna circuit, External IF
DSC, DVC	USB2.0, IEEE1394
PC, PDA	USB2.0, IEEE1394, LAN1000BASE
TV, DVD	USB2.0, IEEE1394, HDMI
Game console	Controller, External IF

Ratings and Characteristics

Size	Part No.	Maximum allowable voltage DC (V)	Nominal varistor voltage at 1mA (V)	Capacitance (pF) at 1MHz	Maximum ESD IEC61000-4-2
0402	EZJZ0V80010	10	80	1 max. [0.8 typ.]	Contact discharge : 8kV
	EZJZ0V80015D	5	80	1.5±0.5	
	EZJZ0V500AA	5	50	3 max. [2.1 typ.]	
	EZJZ0V800AA	18	80	3 max. [2.1 typ.]	
	EZJZ0V171AA	18	170	3 max. [2.1 typ.]	
0603	EZJZ1V80010	10	80	1 max. [0.8 typ.]	
	EZJZ1V500AA	5	50	3 max. [2.1 typ.]	
	EZJZ1V800AA	18	80	3 max. [2.1 typ.]	
	EZJZ1V171AA	18	170	3 max. [2.1 typ.]	

- Operating Temperature Range: -40 to 85 °C
- * Recommend soldering method : Reflow soldering

Voltage vs. Current

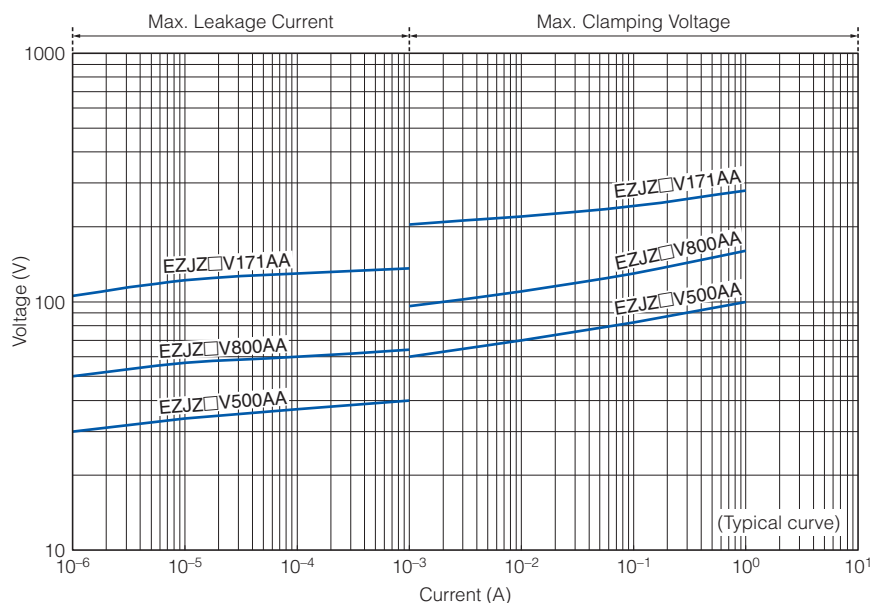

Capacitance vs. Frequency

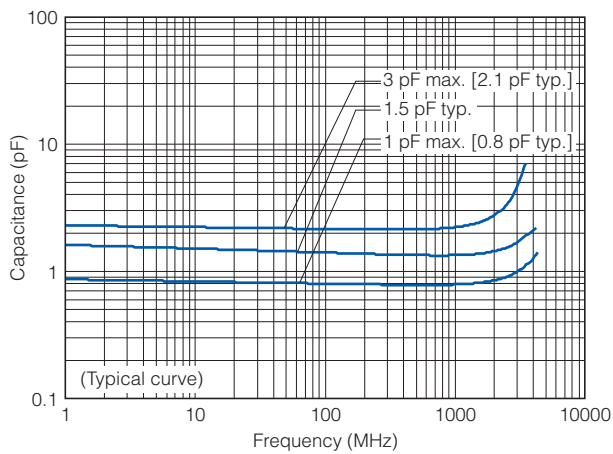

Impedance vs. Frequency

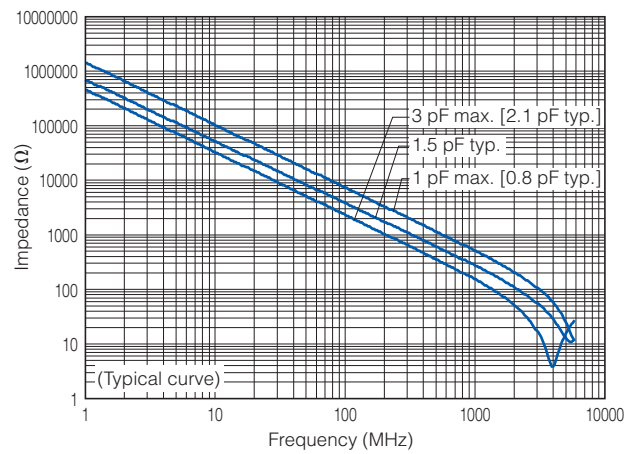

Attenuation vs. Frequency

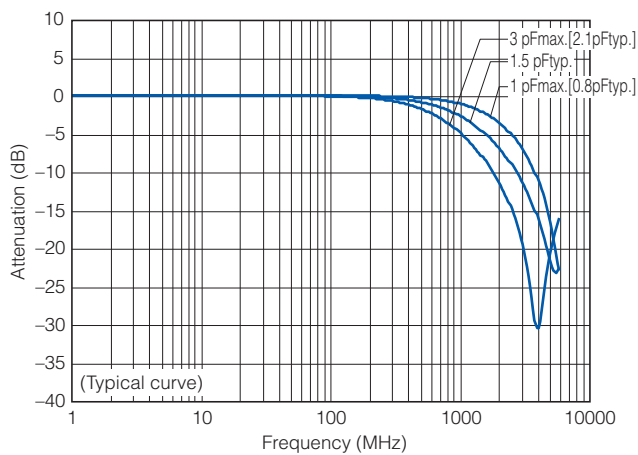

Multilayer Varistor, Low Voltage Type (Standard Type) [DC voltage lines/Low speed signal lines]

Features

Wide variety of products is available by adopting multilayer construction, which achieved wide range of usage, such as application to DC voltage lines and signal lines.

- Circuit voltage

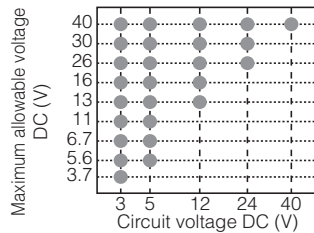

- Varistor voltage : 6.8 to 65 V [at 1 mA]
- Capacitance : 8.5 to 420 pF typ. [at 1 MHz]

Recommended Applications

Mobile phone	SW, LCD, LED, Audio terminal, Battery pack, Memory card, External IF
DSC, DVC	SW, LCD, LED, USB
PC, PDA	SW, LCD, LED, USB
TV, DVD	Audio, Video terminal
Audio	Audio terminal, Microphone, Receiver
Game console	Controller, External IF

Ratings and Characteristics

Size	Part No.	Maximum allowable voltage DC (V)	Nominal varistor voltage at 1mA (V)	Capacitance (pF)		Maximum peak current at 8/20μs, 2times (A)	Maximum ESD IEC61000-4-2
				at 1MHz	at 1kHz		
0201	EZJPZV6R8JA	3.7	6.8	220 max. [180 typ.]	175 typ.	5	Contact discharge 8 kV
	EZJPZV6R8GA	3.7	6.8	100 max. [85 typ.]	100 typ.	5	
	EZJPZV080GA	5.6	8	100 max. [85 typ.]	100 typ.	5	
	EZJPZV120GA	7.5	12	100 max. [85 typ.]	100 typ.	5	
	EZJPZV120DA	7.5	12	27 max. [22 typ.]	33 typ.	1	
	EZJPZV120RA	7.5	12	20 max. [15 typ.]	18 typ.	1	
	EZJPZV150RA	9	15	20 max. [15 typ.]	18 typ.	1	
	EZJPZV270RA	16	27	20 max. [15 typ.]	16.5 typ.	1	
0402	EZJPZV270BA	16	27	10 max. [8.5 typ.]	10 typ.	1	
	EZJP0V6R8MA	3.7	6.8	680 max. [420 typ.]	650 typ.	20	
	EZJP0V6R8GA	3.7	6.8	100 max. [85 typ.]	100 typ.	3	
	EZJP0V080MA	5.6	8	680 max. [420 typ.]	650 typ.	20	
	EZJP0V080KA	5.6	8	330 max. [290 typ.]	480 typ.	15	
	EZJP0V080GA	5.6	8	100 max. [65 typ.]	100 typ.	3	
	EZJP0V080DA	5.6	8	27 max. [22 typ.]	33 typ.	1	
	EZJP0V120JA	6.7	12	220 max. [150 typ.]	175 typ.	10	
	EZJZ0V180HA	11	18	150 max. [120 typ.]	140 typ.	10	
	EZJZ0V220HA	13	22	150 max. [100 typ.]	116 typ.	10	
	EZJP0V270EA	16	27	47 max. [33 typ.]	37 typ.	4	
	EZJP0V270RA	16	27	20 max. [15 typ.]	16.5 typ.	1	
0603	EZJZ0V420WA	30	42	56 max. [40 typ.]	45 typ.	10	
	EZJZ0V650DA	40	65	27 max. [22 typ.]	33 typ.	5	
	EZJP1V120KA	6.7	12	330 max. [250 typ.]	290 typ.	20	
	EZJZ1V180JA	11	18	220 max. [180 typ.]	210 typ.	20	
	EZJZ1V220JA	13	22	220 max. [160 typ.]	185 typ.	20	
	EZJZ1V270GA	16	27	100 max. [85 typ.]	100 typ.	20	
	EZJZ1V270EA	16	27	47 max. [33 typ.]	37 typ.	20	
	EZJZ1V270RA	16	27	20 max. [15 typ.]	16.5 typ.	3	
	EZJZ1V330GA	26	33	100 max. [85 typ.]	100 typ.	20	
	EZJZ1V420FA	30	42	68 max. [55 typ.]	63 typ.	15	
EZJZ1V650DA	40	65	27 max. [22 typ.]	33 typ.	5		

- Operating Temperature Range: -40 to 85 °C * Recommend soldering method : Reflow soldering

Maximum Allowable Voltage	Maximum DC Voltage that can be applied continuously within the operating temperature range
Varistor Voltage	Varistor starting voltage between terminals at DC 1 mA, also known as Breakdown voltage
Maximum Peak Current	Maximum current that can be withstood under the standard pulse 8/20 μs, 2 times based
Maximum ESD	Maximum voltage that can be withstood under ESD based on IEC61000-4-2, 10 times (5 times of each positive-negative polarity)

Voltage vs. Current

● EZJP Series

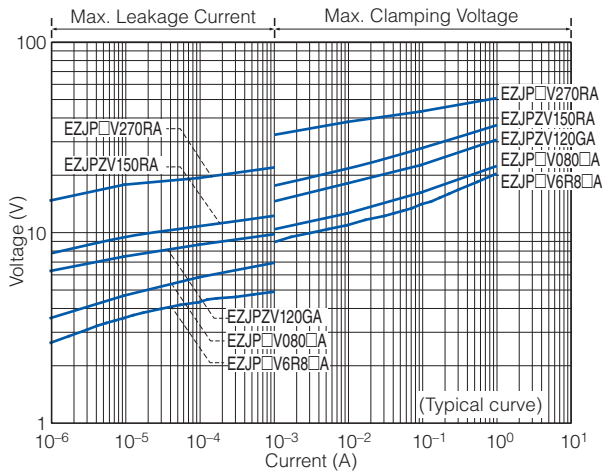

● EZJZ Series

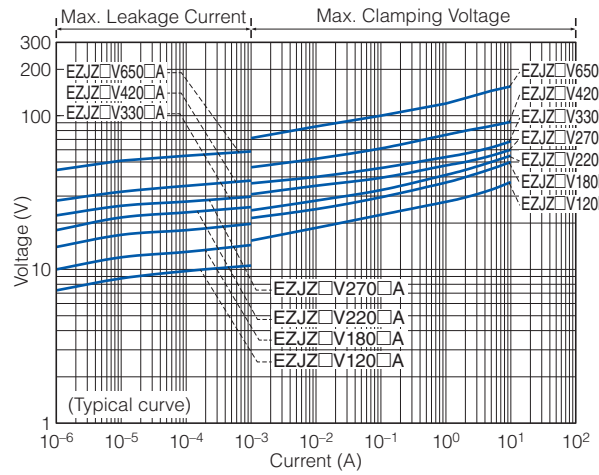

Capacitance vs. Frequency

● EZJP Series

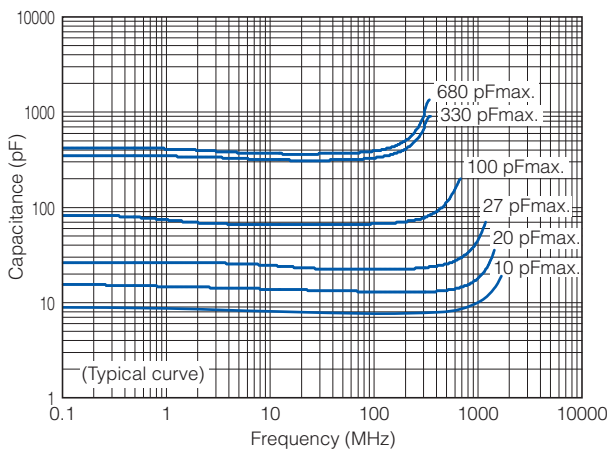

● EZJZ Series

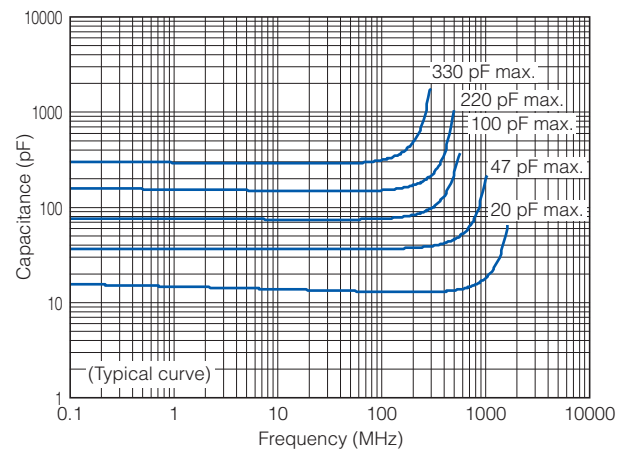

Attenuation vs. Frequency

● EZJP Series

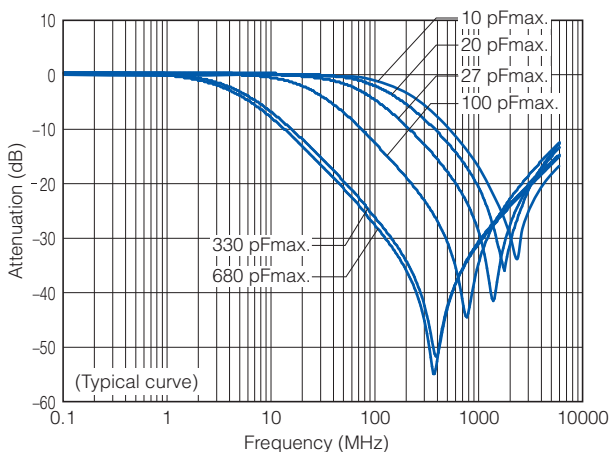

● EZJZ Series

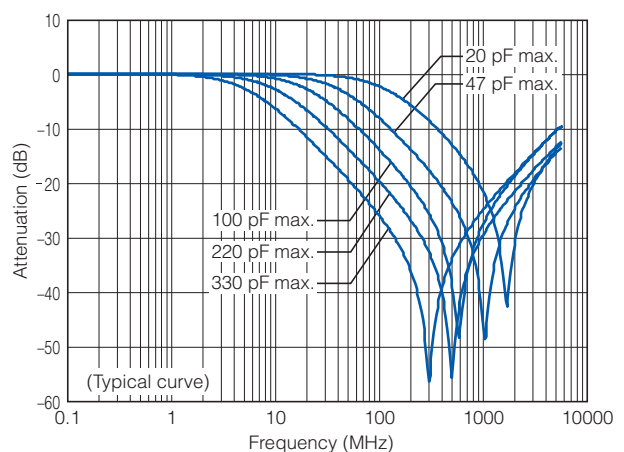

Multilayer Varistor for ESD pulse [DC voltage lines]

Series: **EZJS**



Features

- Excellent ESD suppression due to original advanced material technology
- Having large electrostatic resistance meeting IEC61000-4-2, Special Level 30 kV standard
- Having no polarity (bipolar) facilitated replacing Zener Diodes. Capable of replacing 2 Zener Diodes and 1 Capacitor.
- Lead-free terminal electrodes enabling great solderability
- RoHS compliant

As for Packaging Methods, Handling Precautions

Please see Data Files

Explanation of Part Numbers

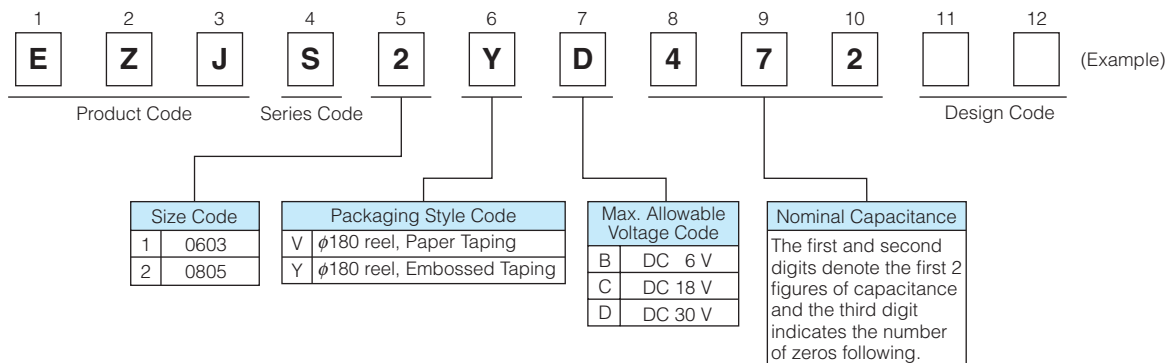

Construction

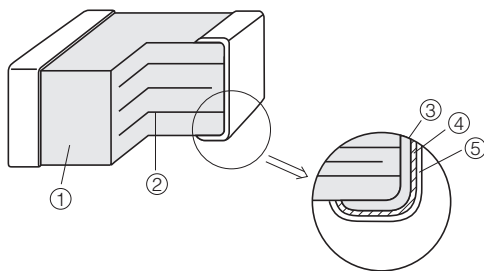

No.	Name
①	Semiconductive Ceramics
②	Internal electrode
③	Substrate electrode
④	Terminal electrode
⑤	External electrode

Dimensions in mm (not to scale)

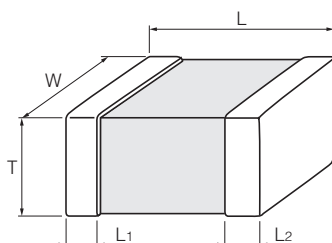

Size Code	Size(inch)	L	W	T	L ₁ , L ₂
1	0603	1.60±0.15	0.8±0.1	0.8±0.1	0.3±0.2
2	0805	2.0±0.2	1.25±0.20	0.8±0.2 1.25±0.20	0.50±0.25

Ratings and Characteristics

Size	Part No.	Maximum Allowable Voltage DC (V)	Nominal Varistor Voltage at 0.1 mA (V)	Capacitance at 1 kHz (pF)	Maximum ESD IEC61000-4-2
0603	EZJS1VB822	6	12	8200 typ.	Contact discharge : 30 kV
	EZJS1VC392	18	30	3900 typ.	
	EZJS1VD182	30	50	1800 typ.	
0805	EZJS2VB223	6	12	22000 typ.	
	EZJS2YC822	18	30	8200 typ.	
	EZJS2YD472	30	50	4700 typ.	

● Operating Temperature Range: -40 to 85 °C

* Avoid flow soldering

Voltage vs. Current

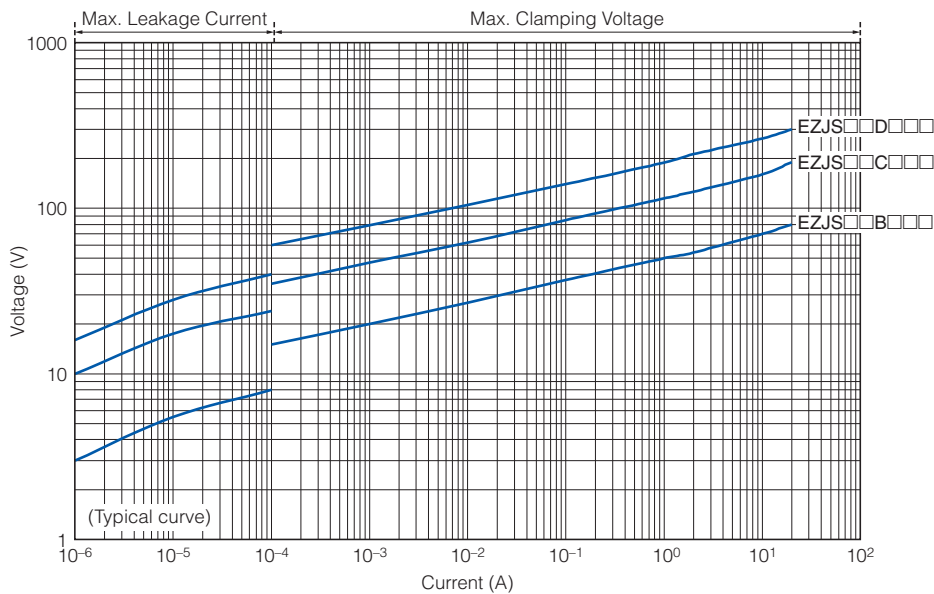

Capacitance vs. Frequency

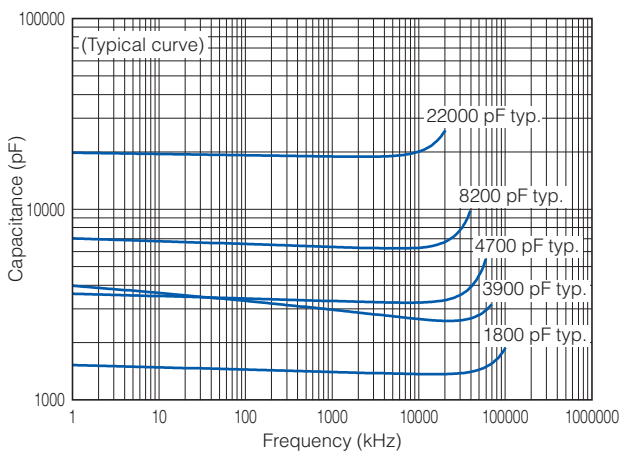

Attenuation vs. Frequency

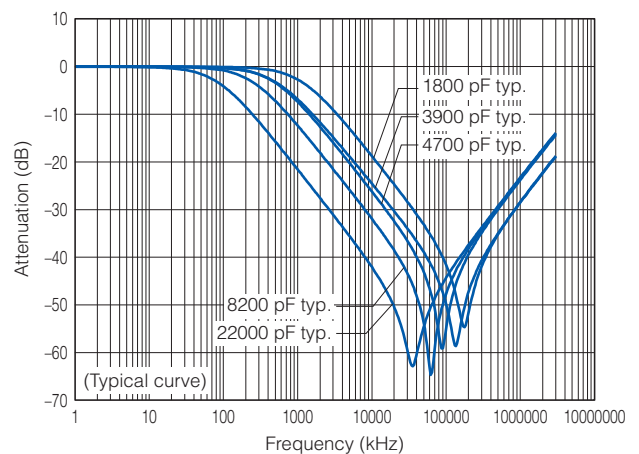

Varistor Characteristics and Equivalent Circuit

A Multilayer Varistor does not have an electrical polarity like zener diodes and is equivalent to total 3 pcs. of 2 zener diodes and 1 capacitor.

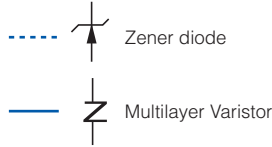
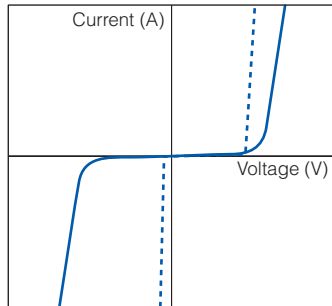

[Equivalent Circuit]

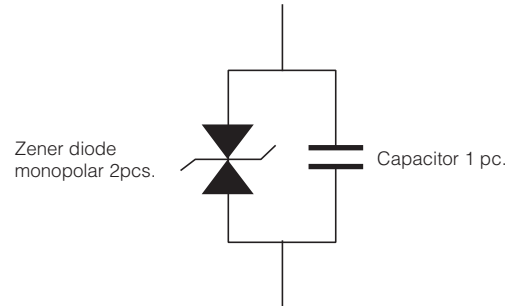

ESD Suppressive Effects

Typical effects of ESD suppression

Test conditions: IEC61000-4-2* Level 4 Contact discharge, 8 kV

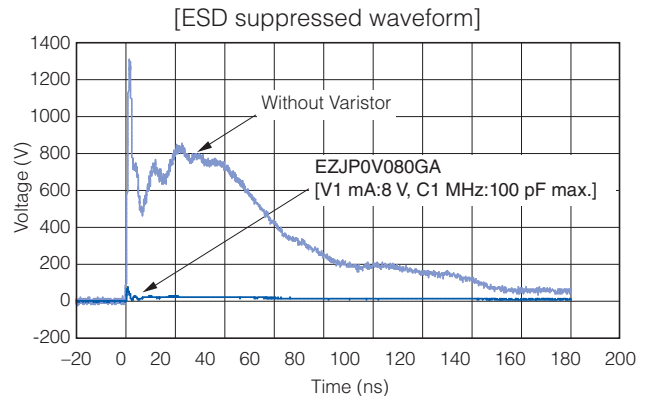
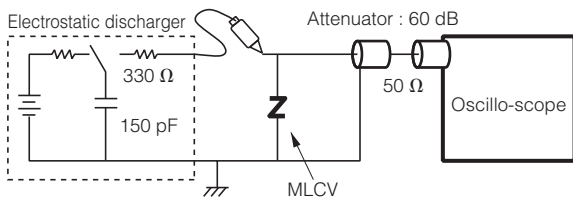

* IEC61000-4-2 ... International Standard of the ESD testing method (HBM) for electronic equipment ability to withstand ESD generated from a human body. It sets 4 levels of severity

Severity	Level 1	Level 2	Level 3	Level 4
Contact discharge	2 kV	4 kV	6 kV	8 kV
Air discharge	2 kV	4 kV	8 kV	15 kV

Replacement of Zener diode

Replacing "Zener diode and Capacitor" with Multilayer Varistor saves both the mounting area and number of components used.

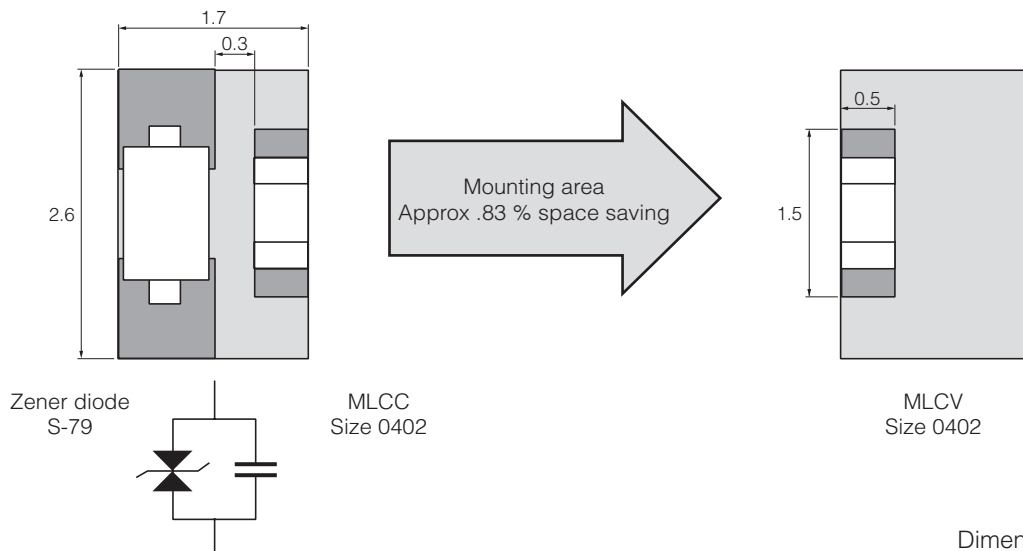

Dimensions in mm

Recommended Applications

Applications	Series	Circuit	Frequency		
			DC	1k	1M
Mobile phones, DSC, PC, PDA, HDD TV (PDP, LC etc.), DVD, DVC, Game consoles, Audio equipment	Series EZJZ, P	Ultra low capacitance (Cap. : 3 pF or less)	[Bar chart showing high performance up to 1G Hz]		
		Low capacitance (Cap. : 20 to 680 pF)	[Bar chart showing performance up to 1M Hz]		
PWR, Photoelectric sensors, SSR, Motors, Pressure sensors, Proximity switches	Series EZJS	High capacitance (Cap. : 1800 to 22000 pF)	[Bar chart showing performance up to 1k Hz]		

Applications

● Mobile Phone

· Audio lines

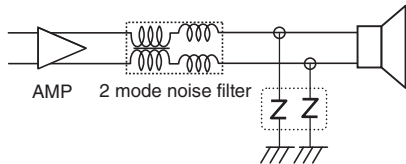

· LED

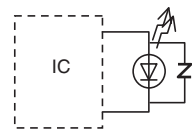

· SW/Keyboard

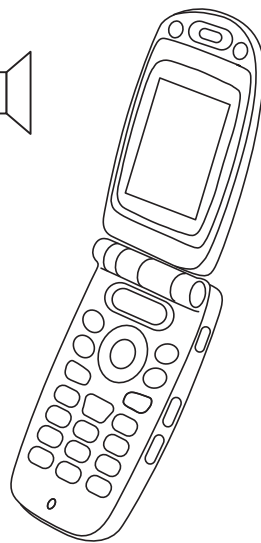
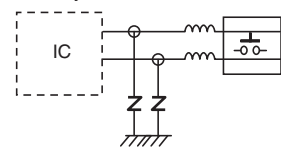

· LCD/Camera lines

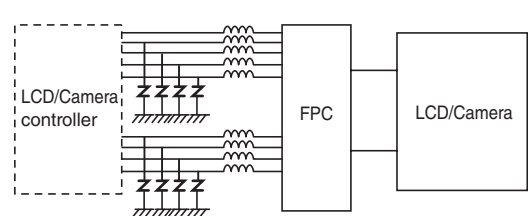

· I/O data lines

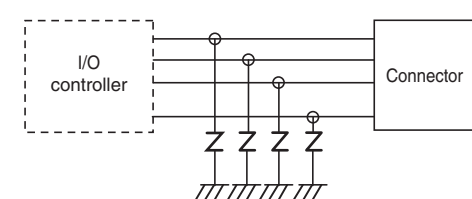

● USB1.1/2.0 lines

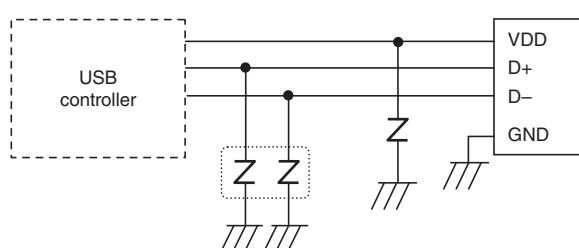

● IEEE1394 lines

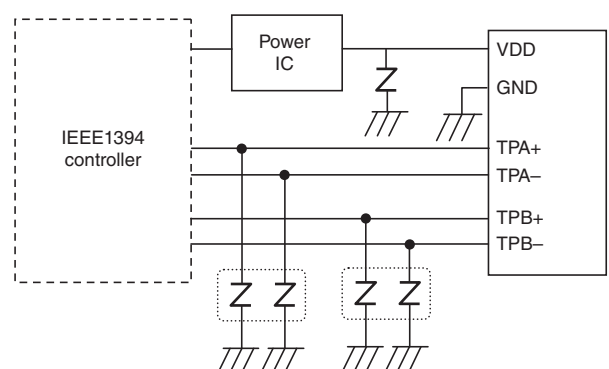

● HDMI lines

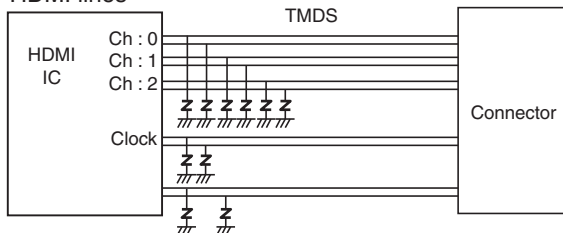

Performance and Testing Methods

Characteristics	Specifications	Testing Method															
Standard test conditions		Electrical characteristics shall be measured under the following conditions. Temp. : 5 to 35 °C, Relative humidity : 85 % or less															
Varistor voltage	To meet the specified value.	The Varistor voltage is the voltage (V_c , or V_{cMA}) between both end terminals of a Varistor when specified current (C_{mA}) is applied to it. The measurement shall be made as quickly as possible to avoid heating effects.															
Maximum allowable voltage	To meet the specified value.	The maximum DC voltage that can be applied continuously to a varistor.															
Capacitance	To meet the specified value.	Capacitance shall be measured at the specified frequency, bias voltage 0 V, and measuring voltage 0.2 to 2 Vrms.															
Maximum peak current	To meet the specified value.	The maximum current measured (Varistor voltage tolerance is within $\pm 10\%$) when a standard impulse current of $8/20 \mu$ seconds is applied twice with an interval of 5 minutes.															
Maximum ESD	To meet the specified value.	The maximum ESD measured (while the varistor voltage is within $\pm 30\%$ of its nominal value) when exposed to ESD 10 times (five times for each positive-negative polarity) based on IEC61000-4-2.															
Solder ability	To meet the specified value.	The part shall be immersed into a soldering bath under the conditions below. Solder: H63A Soldering flux : Ethanol solution of rosin (Concentration approx. 25 wt%) Soldering temp. : 230 ± 5 °C Period : 4 ± 1 s Soldering position: Immerse both terminal electrodes until they are completely into the soldering bath.															
Resistance to soldering heat	$\Delta V_c / V_c$: within $\pm 10\%$	After the immersion, leave the part for 24 ± 2 hours under the standard condition, then evaluate its characteristics. Soldering conditions are specified below: Soldering conditions : 270 °C, 3 s / 260 °C, 10 s Soldering position : Immerse both terminal electrodes until they are completely into the soldering bath.															
Temperature cycling	$\Delta V_c / V_c$: within $\pm 10\%$	After repeating the cycles stated below for specified number of times, leave the part for 24 ± 2 hours, then evaluate its characteristics. Cycle : 5 cycles <table border="1" style="margin-left: auto; margin-right: auto;"> <thead> <tr> <th>Step</th> <th>Temperature</th> <th>Period</th> </tr> </thead> <tbody> <tr> <td>1</td> <td>Max. Operating Temp.</td> <td>30 ± 3 min</td> </tr> <tr> <td>2</td> <td>Ordinary temp.</td> <td>3 min max.</td> </tr> <tr> <td>3</td> <td>Min. Operating Temp.</td> <td>30 ± 3 min</td> </tr> <tr> <td>4</td> <td>Ordinary temp.</td> <td>3 min max.</td> </tr> </tbody> </table>	Step	Temperature	Period	1	Max. Operating Temp.	30 ± 3 min	2	Ordinary temp.	3 min max.	3	Min. Operating Temp.	30 ± 3 min	4	Ordinary temp.	3 min max.
Step	Temperature	Period															
1	Max. Operating Temp.	30 ± 3 min															
2	Ordinary temp.	3 min max.															
3	Min. Operating Temp.	30 ± 3 min															
4	Ordinary temp.	3 min max.															
Biased Humidity	$\Delta V_c / V_c$: within $\pm 10\%$	After conducting the test under the conditions specified below, leave the part 24 ± 2 hours, then evaluate its characteristics. Temp. : 40 ± 2 °C Humidity : 90 to 95 %RH Applied voltage : Maximum allowable voltage (Individually specified) Period : $500 + 24 / 0$ h															
High temperature exposure (dry heat)	$\Delta V_c / V_c$: within $\pm 10\%$	After conducting the test under the conditions specified below, leave the part 24 ± 2 hours, then evaluate its characteristics. Temp. : Maximum operating temperature ± 3 °C (Individually specified) Applied voltage : Maximum allowable voltage (Individually specified) Period : $500 + 24 / 0$ h															

Packaging Methods

● Standard Packing Quantity

Series	Size Code (EIA)	Thickness (mm)	Kind of Taping	Pitch (mm)	Quantity (pcs/reel)
EZJZ EZJP	Z (0201)	0.3	Pressed Carrier Taping	2	15,000
	0 (0402)	0.5			10,000
	1 (0603)	0.8	Punched Carrier Taping	4	4,000
EZJS	1 (0603)	0.8			4,000
	2 (0805)	0.8			5,000
		1.25	Embossed Carrier Taping		2,000

● Pitch 2mm (Pressed Carrier Taping) : Size 0201/EIA

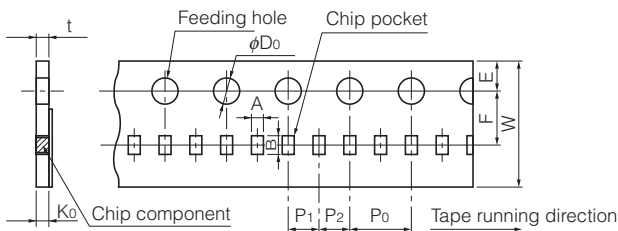

(Unit : mm)

Size Code	A	B	W	F	E	P ₁	P ₂	P ₀	φD ₀	t	K ₀
Z	0.36 ±0.08	0.66 ±0.03	8.0 ±0.2	3.50 ±0.05	1.75 ±0.10	2.00 ±0.05	2.00 ±0.05	4.0 ±0.1	1.5 +0.1 0	0.55 max.	0.36 ±0.03

● Embossed Carrier Taping : Size 0805/EIA

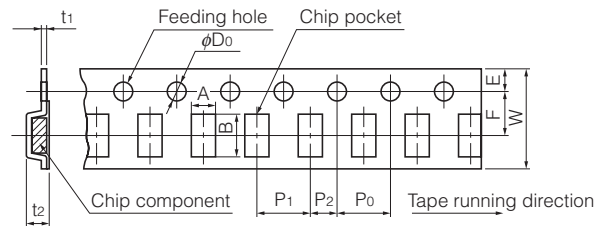

(Unit : mm)

Size Code	A	B	W	F	E	P ₁	P ₂	P ₀	φD ₀	t ₁	t ₂
2	1.55 ±0.20	2.35 ±0.20	8.0 ±0.2	3.50 ±0.05	1.75 ±0.10	4.0 ±0.1	2.00 ±0.05	4.0 ±0.1	1.5 +0.1 0	0.6 max.	1.5 max.

● Pitch 2mm (Punched Carrier Taping) : Size 0402/EIA

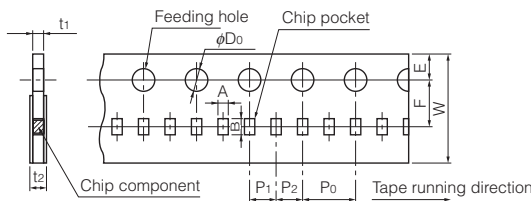

(Unit : mm)

Size Code	A	B	W	F	E	P ₁	P ₂	P ₀	φD ₀	t ₁	t ₂
0	0.62 ±0.05	1.12 ±0.05	8.0 ±0.2	3.50 ±0.05	1.75 ±0.10	2.00 ±0.05	2.00 ±0.05	4.0 ±0.1	1.5 +0.1 0	0.7 max.	1.0 max.

● Pitch 4mm (Punched Carrier Taping) : Size 0603/EIA, 0805/EIA

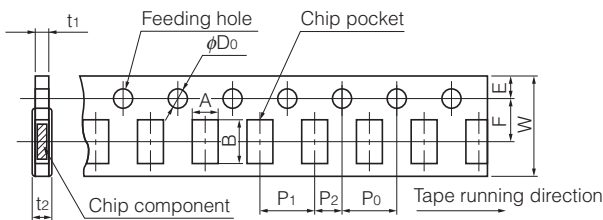

(Unit : mm)

Size Code (EIA)	A	B	W	F	E	P ₁	P ₂	P ₀	φD ₀	t ₁	t ₂
1 (0603)	1.0 ±0.1	1.8 ±0.1	8.0 ±0.2	3.50 ±0.05	1.75 ±0.10	4.0 ±0.1	2.00 ±0.05	4.0 ±0.1	1.5 +0.1 0	1.1 max.	1.4 max.
2 (0805)	1.65 ±0.20	2.4 ±0.2	8.0 ±0.2	3.50 ±0.05	1.75 ±0.10	4.0 ±0.1	2.00 ±0.05	4.0 ±0.1	1.5 +0.1 0	1.1 max.	1.4 max.

● Reel for Taping

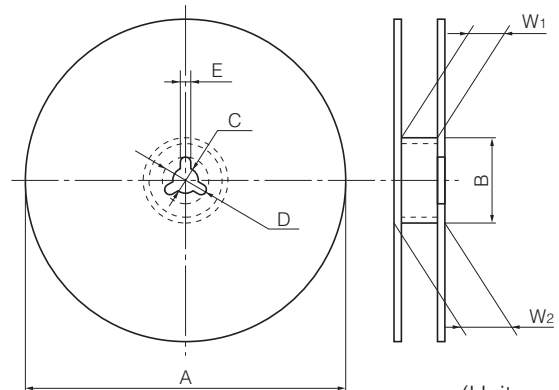

(Unit : mm)

A	B	C	D	E	W ₁	W ₂
φ180 ⁰ ₋₃	φ60.0 ^{+1.0} ₀	13.0±0.5	21.0±0.8	2.0±0.5	9.0 ^{+1.0} ₀	11.4±1.0

● Leader Part and Taped End Leader part

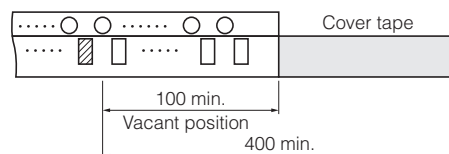

Tape end

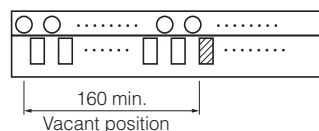

Dimensions in mm

Multilayer Varistors, Chip Type

Series: **EZJZ, EZJP** (For DC voltage lines, high speed signal lines)

Series: **EZJS** (For DC voltage lines)

Handling Precautions

⚠ Safety Precautions

Multilayer Varistors (hereafter referred to as “Varistors”) should be used for general purpose applications as countermeasures against ESD and noise found in consumer electronics (audio/visual, home, office, information & communication) equipment. When subjected to severe electrical, environmental, and/or mechanical stress beyond the specifications, as noted in the Ratings and Specified Conditions section, the Varistors’ performance may be degraded, or become failure mode, such as short circuit mode and open-circuit mode.

If you use under the condition of short-circuit, heat generation of Varistors will occur by running large current due to application of voltage. There are possibilities of smoke emission, substrate burn-out, and, in the worst case, fire.

For products which require high safety levels, please carefully consider how a single malfunction can affect your product. In order to ensure the safety in the case of a single malfunction, please design products with fail-safe, such as setting up protecting circuits, etc.

- For the following applications and conditions, please contact us for additional specifications, which is not found in this document.
 - When your application may have difficulty complying with the safety or handling precautions specified below.
 - High-quality and high-reliability required devices that have possibility of causing hazardous conditions, such as death or injury (regardless of directly or indirectly), due to failure or malfunction of the product.
 - ① Aircraft and Aerospace Equipment (artificial satellite, rocket, etc.)
 - ② Submarine Equipment (submarine repeating equipment, etc.)
 - ③ Transportation Equipment (motor vehicles, airplanes, trains, ship, traffic signal controllers, etc.)
 - ④ Power Generation Control Equipment (atomic power, hydroelectric power, thermal power plant control system, etc.)
 - ⑤ Medical Equipment (life-support equipment, pacemakers, dialysis controllers, etc.)
 - ⑥ Information Processing Equipment (large scale computer systems, etc.)
 - ⑦ Electric Heating Appliances, Combustion devices (gas fan heaters, oil fan heaters, etc.)
 - ⑧ Rotary Motion Equipment
 - ⑨ Security Systems
 - ⑩ And any similar types of equipment

⚠ Strict Observance

1. Confirmation of Rated Performance

The Varistors shall be operated within the specified rating/performance.

Applications exceeding the specifications may cause deteriorated performance and/or breakdown, resulting in degradation and/or smoking or ignition of products. The following are strictly observed.

- (1) The Varistors shall not be operated beyond the specified operating temperature range.
- (2) The Varistors shall not be operated in excess of the specified maximum allowable voltage.
- (3) The Varistors shall not be operated in the circuits to which surge current and ESD that exceeds the specified maximum peak current and maximum ESD.
- (4) Never use for AC power supply circuits.

2. The Varistors shall not be mounted near flammables.

Operating Conditions and Circuit Design

1. Circuit Design

1.1 Operating Temperature and Storage Temperature

When operating a components-mounted circuit, please be sure to observe the “Operating Temperature Range”, written in delivery specifications. Storage temperature of PCB after mounting Varistors, which is not operated, should be within the specified “Storage Temperature Range” in the delivery specifications. Please remember not to use the product under the condition that exceeds the specified maximum temperature.

1.2 Operating Voltage

The Varistors shall not be operated in excess of the “Maximum allowable voltage”. If the Varistors are operated beyond the specified Maximum allowable voltage, it may cause short and/or damage due to thermal run away.

The circuit that continuously applies high frequency and/or steep pulse voltage please examines the reliability of the Varistor even if it is used within a “Maximum allowable voltage”. Also, it would be safer to check also the safety and reliability of your circuit.

1.3 Self-heating

The surface temperature of the Varistors shall be under the specified Maximum Operating Temperature in the Specifications including the temperature rise caused by self-heating. Check the temperature rise of the Varistor in your circuit.

1.4 Environmental Restrictions

The Varistors shall not be operated and/or stored under the following conditions.

- (1) Environmental conditions
 - (a) Under direct exposure to water or salt water
 - (b) Under conditions where water can condense and/or dew can form
 - (c) Under conditions containing corrosive gases such as hydrogen sulfide, sulfurous acid, chlorine and ammonia
- (2) Mechanical conditions

The place where vibration or impact that exceeds specified conditions written in delivery specification is loaded.

2. Design of Printed Circuit Board

2.1 Selection of Printed Circuit Boards

There is a possibility of performance deterioration by heat shock (temperature cycles), which causes cracks, from alumina substrate.

Please confirm that the substrate you use does not deteriorate the Varistors' quality.

2.2 Design of Land Pattern

- (1) Recommended land dimensions are shown below. Use the proper amount of solder in order to prevent cracking. Using too much solder places excessive stress on the Varistors.

Recommended Land Dimensions

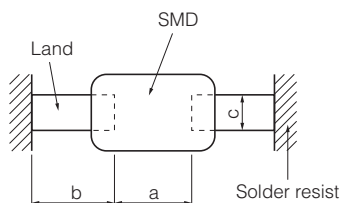

Unit (mm)

Size Code (EIA)	Component dimensions			a	b	c
	L	W	T			
Z(0201)	0.6	0.3	0.3	0.2 to 0.3	0.25 to 0.30	0.2 to 0.3
0(0402)	1.0	0.5	0.5	0.4 to 0.5	0.4 to 0.5	0.4 to 0.5
1(0603)	1.6	0.8	0.8	0.8 to 1.0	0.6 to 0.8	0.6 to 0.8
2(0805)	2.0	1.25	0.8 to 1.25	0.8 to 1.2	0.8 to 1.0	0.8 to 1.0

- (2) The land size shall be designed to have equal space, on both right and left side. If the amount of solder on the right land is different from that of the left land, the component may be cracked by stress since the side with a larger amount of solder solidifies later during cooling.

Recommended Amount of Solder

- (a) Excessive amount (b) Proper amount (c) Insufficient amount

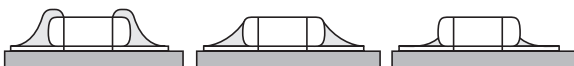

2.3 Utilization of Solder Resist

- (1) Solder resist shall be utilized to equalize the amounts of solder on both sides.
- (2) Solder resist shall be used to divide the pattern for the following cases;
 - Components are arranged closely.
 - The Varistor is mounted near a component with lead wires.
 - The Varistor is placed near a chassis.
 See the table below.

Prohibited Applications and Recommended Applications

Item	Prohibited applications	Improved applications by pattern division
Mixed mounting with a component with lead wires	The lead wire of a Component With lead wires	Solder resist
Arrangement near chassis	Chassis Solder (ground solder) Electrode pattern	Solder resist
Retro-fitting of component with lead wires	A lead wire of Retrofitted component Soldering iron	Solder resist
Lateral arrangement	Portion to be Excessively soldered Land	Solder resist

2.4 Component Layout

To prevent the crack of Varistors, place it on the position that could not easily be affected by the bending stress of substrate while going through procedures after mounting or handling.

- (1) To minimize mechanical stress caused by the warp or bending of a PC board, please follow the recommended Varistors' layout below.

Prohibited layout	Recommended layout
	 Layout the Varistors sideways against the stressing direction.

- (2) The following layout is for your reference since mechanical stress near the dividing/breaking position of a PC board varies depending on the mounting position of the Varistors.

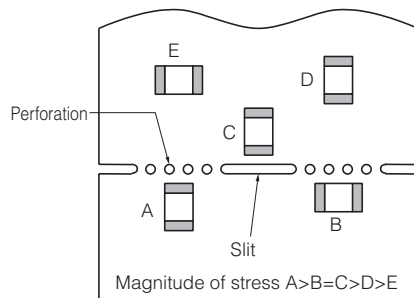

- (3) The magnitude of mechanical stress applied to the Varistors when dividing the circuit board in descending order is as follows: push back < slit < V-groove < perforation. Also take into account the layout of the Varistors and the dividing/breaking method.

2.5 Mounting Density and Spaces

Intervals between components should not be too narrow to prevent the influence from solder bridges and solder balls. The space between components should be carefully determined.

Precautions for Assembly

1. Storage

- The Varistors shall be stored between 5 to 40 °C and 20 to 70 % RH, not under severe conditions of high temperature and humidity.
- If stored in a place where humidity, dust, or corrosive gasses (hydrogen sulfide, sulfurous acid, hydrogen chloride and ammonia, etc.) are contained, the solderability of terminals electrodes will be deteriorated.
In addition, storage in a place where the heat or direct sunlight exposure occurs will causes mounting problems due to deformation of tapes and reels and components and taping/reels sticking together.
- Do not store components longer than 6 months. Check the solderability of products that have been stored for more than 6 months before use.

2. Adhesives for Mounting

- The amount and viscosity of an adhesive for mounting shall be such that the adhesive will not flow off on the land during its curing.
- If the amount of adhesive is insufficient for mounting, the Varistors may fall off after or during soldering.
- Low-viscosity of the adhesive causes displacement of Varistors.

- The heat-curing methods for adhesive are ultraviolet radiation, far-infrared radiation, and so on. In order to prevent the terminal electrodes of the Varistors from oxidizing, the curing shall be under the following conditions:
160 °C max., for 2 minutes max.
- Insufficient curing may cause the Varistors to fall off after or during soldering. In addition, insulation resistance between terminal electrodes may deteriorate due to moisture absorption. In order to prevent these problems, please observe proper curing conditions.

3. Chip Mounting Consideration

- When mounting the Varistors components on a PC board, the Varistor bodies shall be free from excessive impact loads such as mechanical impact or stress due to the positioning, pushing force and displacement of vacuum nozzles during mounting.
- Maintenance and inspection of the Chip Mounter must be performed regularly.
- If the bottom dead center of the vacuum nozzle is too low, the Varistor will crack from excessive force during mounting.
Please refer to the following precautions and recommendations.
 - Set and adjust the bottom dead center of the vacuum nozzles to the upper surface of the PC board after correcting the warp of the PC board.
 - Set the pushing force of the vacuum nozzle during mounting to 1 to 3 N in static load.
 - For double surface mounting, apply a supporting pin on the rear surface of the PC board to suppress the bending of the PC board in order to minimize the impact of the vacuum nozzles. Typical examples are shown in the table below.
 - Adjust the vacuum nozzles so that their bottom dead center during mounting is not too low.

Item	Prohibited mounting	Recommended mounting
Single surface mounting		 The supporting pin does not necessarily have to be positioned beneath the Varistor.
Double surface mounting		

- (4) The closing dimensions of the positioning chucks shall be controlled. Maintenance and replacement of positioning chucks shall be performed regularly to prevent chipping or cracking of the Varistors caused by mechanical impact during positioning due to worn positioning chucks.
- (5) Maximum stroke of the nozzle shall be adjusted so that the maximum bending of PC board does not exceed 0.5 mm at 90 mm span. The PC board shall be supported by an adequate number of supporting pins.

4. Selection of Soldering Flux

Soldering flux may seriously affect the performance of the Varistors. Please confirm enough whether the soldering flux have an influence on performance of the Varistors or not, before using.

5. Soldering

5.1 Flow Soldering

When conducting flow soldering, stress from abrupt temperature change is applied to the Varistors, so the temperature, especially temperature of solder should be controlled very carefully. Varistors should not be subjected to abrupt temperature change because it causes occurrence of thermal cracks as a result of excessive thermal stress inside of the Varistors from flow soldering. You should be careful to temperature difference. Therefore it is essential that soldering process follow these recommended conditions.

(1) Application of Soldering flux :

The soldering flux shall be applied to the mounted Varistors thinly and uniformly by foaming method.

(2) Preheating :

Conduct sufficient pre-heating, and make sure that the temperature difference between solder and Varistors' surface is 150 °C or less.

(3) Immersion into Soldering bath :

The Varistors shall be immersed into a soldering bath of 240 to 260 °C for 3 to 5 seconds.

(4) Gradual Cooling :

After soldering, avoid rapid cooling (forced cooling) and conduct gradual cooling, so that thermal cracks do not occur.

(5) Flux Cleaning :

When the Varistors are immersed into a cleaning solvent, be sure that the surface temperatures of devices do not exceed 100 °C.

(6) Performing flow soldering once under the conditions shown in the figure on the right "Recommended profile of Flow soldering (Ex.)" will not cause any problems. However, pay attention to the possible warp and bending of the PC board.

Recommended profile of Flow soldering (Ex.)

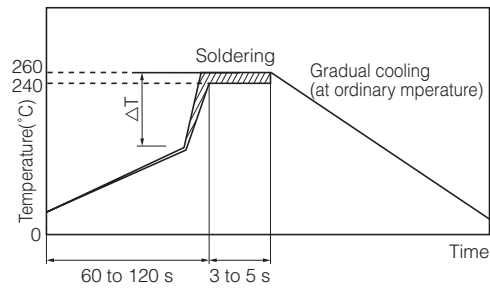

<Allowable temperature difference>

Size	Temp. Tol.
0603/EIA	$\Delta T \leq 150 \text{ }^\circ\text{C}$

For products specified in individual specifications, avoid flow soldering.

5.2 Reflow Soldering

The reflow soldering temperature conditions are composed of temperature curves of Preheating, Temp. rise, Heating, Peak and Gradual cooling. Large temperature difference inside the Varistors caused by rapid heat application to the Varistors may lead to excessive thermal stresses, contributing to the thermal cracks. The Preheating temperature requires controlling with great care so that tombstone phenomenon may be prevented.

Item	Temperature	Period or Speed
① Preheating	140 to 180 °C	60 to 120 s
② Temp. rise	Preheating temp to Peak temp.	2 to 5 °C /s
③ Heating	220 °C min.	60 s max.
④ Peak	260 °C max.	10 s max.
⑤ Gradual cooling	Peak temp. to 140 °C	1 to 4 °C /s

Recommended profile of Reflow soldering (EX.)

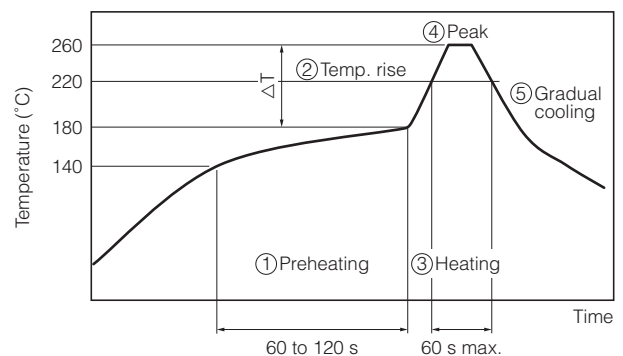

ΔT : Allowable temperature difference $\Delta T \leq 150 \text{ }^\circ\text{C}$

The rapid cooling (forced cooling) during Gradual cooling part should be avoided, because this may cause defects such as the thermal cracks, etc. When the Varistors are immersed into a cleaning solvent, make sure that the surface temperatures of the devices do not exceed 100 °C. Performing reflow soldering twice under the conditions shown in the figure above "Recommended profile of Reflow soldering (Ex.)" will not cause any problems. However, pay attention to the possible warp and bending of the PC board.

5.3 Hand Soldering

Hand soldering typically causes significant temperature change, which may induce excessive thermal stresses inside the Varistors, resulting in the thermal cracks, etc.

In order to prevent any defects, the following should be observed.

- Control the temperature of the soldering tips with special care.
- Avoid the direct contact of soldering tips with the Varistors and/or terminal electrodes.
- Do not reuse dismantled Varistors.

(1) Condition 1 (with preheating)

(a) Soldering :

Use thread solder ($\phi 1$ mm or below) which contains flux with low chlorine, developed for precision electronic equipment.

(b) Preheating :

Conduct sufficient Preheating, and make sure that the temperature difference between solder and Varistors' surface is 150 °C or less.

(c) Temperature of Iron tip: 300 °C max.

(The required amount of solder shall be melted in advance on the soldering tip.)

(d) Gradual cooling :

After soldering, the Varistors shall be cooled gradually at room temperature.

Recommended profile of Hand soldering (Ex.)

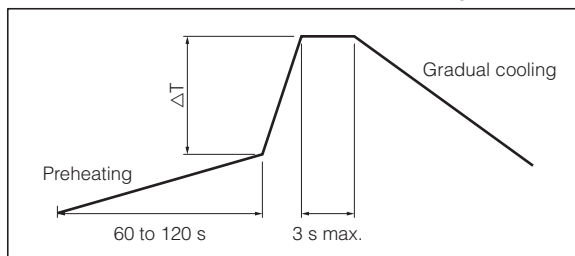

ΔT : Allowable temperature difference $\Delta T \leq 150$ °C

(2) Condition 2 (without preheating)

Hand soldering can be performed without preheating, by following the conditions below:

- (a) Soldering iron tip shall never directly touch the ceramic and terminal electrodes of the Varistors.
- (b) The lands are sufficiently preheated with a soldering iron tip before sliding the soldering iron tip to the terminal electrodes of the Varistors for soldering.

Conditions of Hand soldering without preheating

Item	Condition
Temperature of Iron tip	270 °C max.
Wattage	20 W max.
Shape of Iron tip	$\phi 3$ mm max.
Soldering time with a soldering iron	3 s max.

6. Post Soldering Cleaning

6.1 Cleaning solvent

Soldering flux residue may remain on the PC board if cleaned with an inappropriate solvent. This may deteriorate the performance of Varistors, especially insulation resistance.

6.2 Cleaning conditions

Inappropriate cleaning conditions such as insufficient cleaning or excessive cleaning may impair the electrical characteristics and reliability of the Varistors.

(1) Insufficient cleaning can lead to :

- (a) The halogen substance found in the residue of the soldering flux may cause the metal of terminal electrodes to corrode.
- (b) The halogen substance found in the residue of the soldering flux on the surface of the Varistors may change resistance values.
- (c) Water-soluble soldering flux may have more remarkable tendencies of (a) and (b) above compared to those of rosin soldering flux.

(2) Excessive cleaning can lead to :

- (a) When using ultrasonic cleaner, make sure that the output is not too large, so that the substrate will not resonate. The resonance causes the cracks in Varistors and/or solders, and deteriorates the strength of the terminal electrodes.

Please follow these conditions for Ultrasonic cleaning:

- Ultrasonic wave output : 20 W/L max.
- Ultrasonic wave frequency : 40 kHz max.
- Ultrasonic wave cleaning time : 5 min. max.

6.3 Contamination of Cleaning solvent

Cleaning with contaminated cleaning solvent may cause the same results as that of insufficient cleaning due to the high density of liberated halogen.

7. Inspection Process

The pressure from measuring terminal pins might bend the PCB when implementing circuit inspection after mounting Varistors on PCB, and as a result, cracking may occur.

- (1) Mounted PC boards shall be supported by an adequate number of supporting pins on the back with bend settings of 90 mm span 0.5 mm max.
- (2) Confirm that the measuring pins have the right tip shape, are equal in height, have the right pressure and are set in the correct positions. The following figures are for your reference to avoid bending the PC board.

	Prohibited setting	Recommended setting
Bending of PC board	Separated, Crack	Supporting pin

8. Protective Coating

When the surface of a PC board on which the Varistors have been mounted is coated with resin to protect against moisture and dust, it shall be confirmed that the protective coating does not affect the performance of Varistors.

- (1) Choose the material that does not emit the decomposition and/or reaction gas. The Gas may affect the composing members of the Varistors.
- (2) Shrinkage and expansion of resin coating when curing may apply stress to the Varistors and may lead to occurrence of cracks.

9. Dividing/Breaking of PC Boards

- (1) Please be careful not to stress the substrate with bending/twisting when dividing, after mounting components including Varistors. Abnormal and excessive mechanical stress such as bending or torsion shown below can cause cracking in the Varistors.

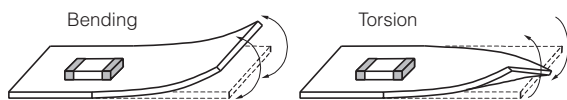

- (2) Dividing/Breaking of the PC boards shall be done carefully at moderate speed by using a jig or apparatus to prevent the Varistors on the boards from mechanical damage.
- (3) Examples of PCB dividing/breaking jigs:
The outline of PC board breaking jig is shown below. When PC board are broken or divided, loading points should be close to the jig to minimize the extent of the bending.
Also, planes with no parts mounted on should be used as plane of loading, in order to prevent tensile stress induced by the bending, which may cause cracks of the Varistors or other parts mounted on the PC boards.

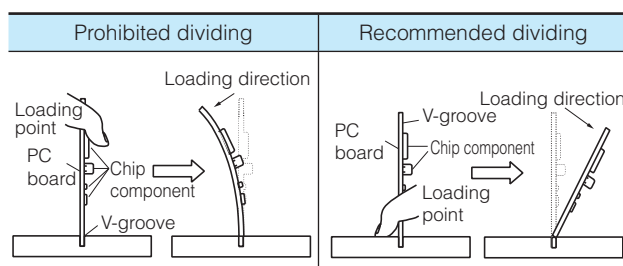
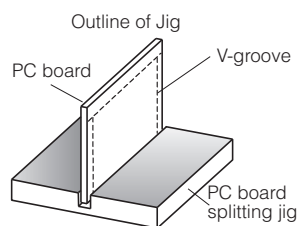

10. Mechanical Impact

- (1) The Varistors shall be free from any excessive mechanical impact. The Varistor body is made of ceramics and may be damaged or cracked if dropped. Never use a Varistor which has been dropped; their quality may already be impaired, and in that case, failure rate will increase.
- (2) When handling PC boards with Varistors mounted on them, do not allow the Varistors to collide with another PC board.

When mounted PC boards are handled or stored in a stacked state, the corner of a PC board might strike Varistors, and the impact of the strike may cause damage or cracking and can deteriorate the withstand voltage and insulation resistance of the Varistor.

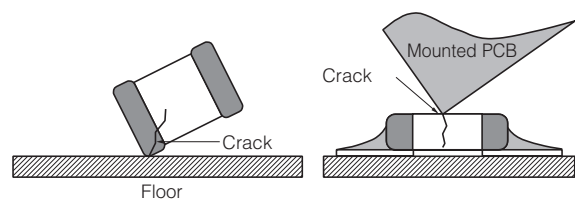

Other

The various precautions described above are typical. For special mounting conditions, please contact us.

Guidelines and precautions regarding the technical information and use of our products described in this online catalog.

- If you want to use our products described in this online catalog for applications requiring special qualities or reliability, or for applications where the failure or malfunction of the products may directly jeopardize human life or potentially cause personal injury (e.g. aircraft and aerospace equipment, traffic and transportation equipment, combustion equipment, medical equipment, accident prevention, anti-crime equipment, and/or safety equipment), it is necessary to verify whether the specifications of our products fit to such applications. Please ensure that you will ask and check with our inquiry desk as to whether the specifications of our products fit to such applications use before you use our products.
- The quality and performance of our products as described in this online catalog only apply to our products when used in isolation. Therefore, please ensure you evaluate and verify our products under the specific circumstances in which our products are assembled in your own products and in which our products will actually be used.
- If you use our products in equipment that requires a high degree of reliability, regardless of the application, it is recommended that you set up protection circuits and redundancy circuits in order to ensure safety of your equipment.
- The products and product specifications described in this online catalog are subject to change for improvement without prior notice. Therefore, please be sure to request and confirm the latest product specifications which explain the specifications of our products in detail, before you finalize the design of your applications, purchase, or use our products.
- The technical information in this online catalog provides examples of our products' typical operations and application circuits. We do not guarantee the non-infringement of third party's intellectual property rights and we do not grant any license, right, or interest in our intellectual property.
- If any of our products, product specifications and/or technical information in this online catalog is to be exported or provided to non-residents, the laws and regulations of the exporting country, especially with regard to security and export control, shall be observed.

<Regarding the Certificate of Compliance with the EU RoHS Directive/REACH Regulations>

- The switchover date for compliance with the RoHS Directive/REACH Regulations varies depending on the part number or series of our products.
- When you use the inventory of our products for which it is unclear whether those products are compliant with the RoHS Directive/REACH Regulation, please select "Sales Inquiry" in the website inquiry form and contact us.

We do not take any responsibility for the use of our products outside the scope of the specifications, descriptions, guidelines and precautions described in this online catalog.

CAUTION AND WARNING

1. The electronic components contained in this catalog are designed and produced for use in home electric appliances, office equipment, information equipment, communications equipment, and other general purpose electronic devices.
Before use of any of these components for equipment that requires a high degree of safety, such as medical instruments, aerospace equipment, disaster-prevention equipment, security equipment, vehicles (automobile, train, vessel), please be sure to contact our sales representative.
2. When applying one of these components for equipment requiring a high degree of safety, no matter what sort of application it might be, be sure to install a protective circuit or redundancy arrangement to enhance the safety of your equipment. In addition, please carry out the safety test on your own responsibility.
3. When using our products, no matter what sort of equipment they might be used for, be sure to make a written agreement on the specifications with us in advance.
4. Technical information contained in this catalog is intended to convey examples of typical performances and/or applications and is not intended to make any warranty with respect to the intellectual property rights or any other related rights of our company or any third parties nor grant any license under such rights.
5. In order to export products in this catalog, the exporter may be subject to the export license requirement under the Foreign Exchange and Foreign Trade Law of Japan.
6. No ozone-depleting substances (ODSs) under the Montreal Protocol are used in the manufacturing processes of Industrial Solutions Company, Panasonic Corporation.
7. The information contained on this material may not be reprinted or reproduced whether wholly or in part, without the prior written permission of Panasonic Corporation.



Safety Precautions

- When using our products, no matter what sort of equipment they might be used for, be sure to confirm the applications and environmental conditions with our specifications in advance.

● Please contact _____

● Factory _____

Device Solutions Business Division
Industrial Solutions Company
Panasonic Corporation
1006 Kadoma, Kadoma City, Osaka 571-8506,
JAPAN

The information in this catalog is valid as of June, 2019.